

# FOR LEASE

**1,118SF Last Space Available (Inline)**

**Grand Square Shopping Center  
1200 Pokegama Avenue South  
GRAND RAPIDS, MINNESOTA 55744**

*One Space Available!*



**LOCATED IN THE HEART OF THE RETAIL BUSINESS DISTRICT OF GRAND RAPIDS, MINNESOTA. IDEAL FOR RESTAURANT, SERVICE, OFFICE, MEDICAL USERS!**

- For Lease: 1,181SF (Office/Retain/Inline)
- Zoning: Commercial—General Business
- Parking Spaces: 195 Spaces
- Current Tenants: Verizon Wireless, Rapids Tidy Laundry, Domino's Pizza, Inspirations Christian Bookstore, North Lakes Chiropractic Clinic, Compass North Psychological Services, Salon Rose', North Shore Title, Superior Credit Union, Fire Fitness, Pinched Catering
- Easy Access Into Site/Highly Visible
- Demographics:



	<u>MILE</u>	<u>3 MILES</u>	<u>5 MILES</u>
Population	3,637	13,114	16,720
Average Age	46	44	45
Average HH Income	\$64,684	\$72,405	\$75,168
Median HH Income	\$50,297	\$53,905	\$56,280



**DIEHL & PARTNERS**

Real Estate Brokerage, Consulting & Development

**FOR MORE INFORMATION, CONTACT:**

**Lisa L. Diehl, CCIM, CPM**

**(612) 508-6410**

**[Lisa.Diehl@CloseTheDiehl.com](mailto:Lisa.Diehl@CloseTheDiehl.com)**

# FOR LEASE

**1,118SF Last Space Available (Inline)**

**Grand Square Shopping Center**  
1200 Pokegama Avenue South  
GRAND RAPIDS, MINNESOTA 55744

Availability in Buildings A/B/C:

- Bay 120 (Building B)—1,118SF (Inline)

195 Parking Spaces  
Great signage  
Monument Signage

\*Inquire on additional available space.



**DIEHL & PARTNERS**  
Real Estate Brokerage, Consulting & Development

FOR MORE INFORMATION, CONTACT:

Lisa L. Diehl, CCIM, CPM

(612) 508-6410

[Lisa.Diehl@CloseTheDiehl.com](mailto:Lisa.Diehl@CloseTheDiehl.com)

# FOR LEASE

**1,118SF Last Space Available (Inline)**

**Grand Square Shopping Center**  
1200 Pokegama Avenue South  
GRAND RAPIDS, MINNESOTA 55744

- **Bay 120—1,118SF (Inline space)**  
Service/retail uses  
Formerly a chiropractic clinic  
ADA restroom

**Bay Size:**

15' 6 1/2" Width x 68' 6" Length

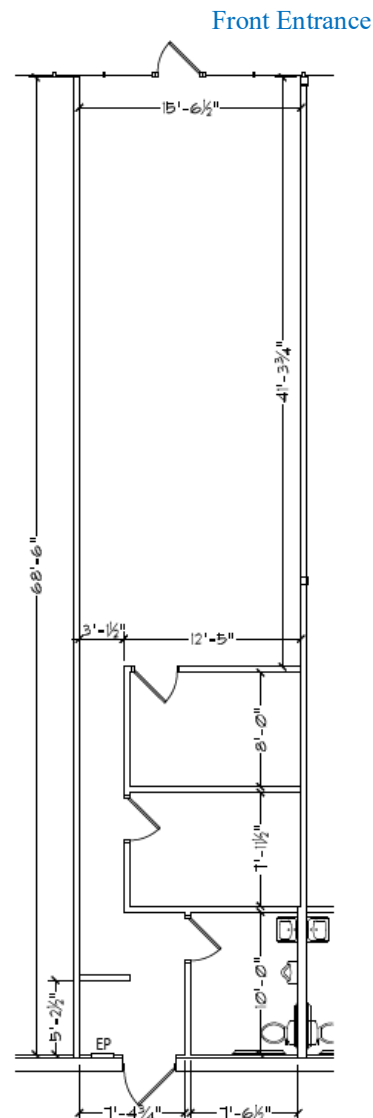

**DIEHL & PARTNERS**

Real Estate Brokerage, Consulting & Development

**FOR MORE INFORMATION, CONTACT:**

**Lisa L. Diehl, CCIM, CPM**

**(612) 508-6410**

**[Lisa.Diehl@CloseTheDiehl.com](mailto:Lisa.Diehl@CloseTheDiehl.com)**