



For Lease

# Office/Flex/Warehouse Units

2570 & 2580 San Ramon Valley Boulevard | San Ramon, CA

Lowest Rates in San Ramon

6% Fee to Procuring Brokerage

## Property Features

- Recent property upgrades
- Immediate access to I-680
- High traffic visibility
- Close proximity to Bishop Ranch
- Nearby retail amenities
- Parking ratio: 4.43/1,000
- Tenant improvements available
- Flexible lease terms (2-year minimum)
- On-site management



Accelerating success.

## Contact Brokers

### George Wineinger

Senior Vice President  
CA License No. 00878573  
george.wineinger@colliers.com  
+1 925 227 6214  
+1 925 963 6569

### Steve Tovani

Senior Vice President  
CA License No. 00890879  
steve.tovani@colliers.com  
+1 925 639 7002

For Lease | 2570 & 2580 San Ramon Valley Boulevard

# Location & Access



2570 & 2580  
San Ramon Valley Blvd

Bishop Ranch	Twin Canyon Shopping Center	Diablo Plaza	Courtyard Center	Magnolia Square	Crow Canyon Commons
<ul style="list-style-type: none"> <li>• Target</li> <li>• Whole Foods</li> <li>• Chipotle</li> <li>• Starbucks</li> <li>• Philz Coffee</li> <li>• Pottery Barn</li> <li>• GAP</li> <li>• Chow</li> </ul>	<ul style="list-style-type: none"> <li>• Ace Auto Repair</li> <li>• DareDevil Dogs</li> <li>• Pho Sam</li> <li>• Beer Area Liquors</li> <li>• Round Table Pizza</li> </ul>	<ul style="list-style-type: none"> <li>• Safeway</li> <li>• CVS</li> <li>• Starbucks</li> <li>• McDonald's</li> <li>• Chipotle</li> <li>• Taco Bell</li> <li>• Dainty Donuts</li> </ul>	<ul style="list-style-type: none"> <li>• Tomahawk Steak, Chops and Seafood</li> <li>• Enterprise Rent-A-Car</li> <li>• Gaucho Brazilian Steakhouse</li> </ul>	<ul style="list-style-type: none"> <li>• Ulta Beauty</li> <li>• On Fire Pizza</li> <li>• Starbucks</li> <li>• Petco</li> <li>• Dumpling 85</li> </ul>	<ul style="list-style-type: none"> <li>• Rite Aid</li> <li>• Plucked Chicken &amp; Beer</li> <li>• Sprouts Farmers Market</li> <li>• Panera Bread</li> <li>• Pizza My Heart</li> <li>• Ace Hardware</li> <li>• Total Wine &amp; More</li> <li>• Carl's Jr.</li> </ul>

# Available Units

## First Floor

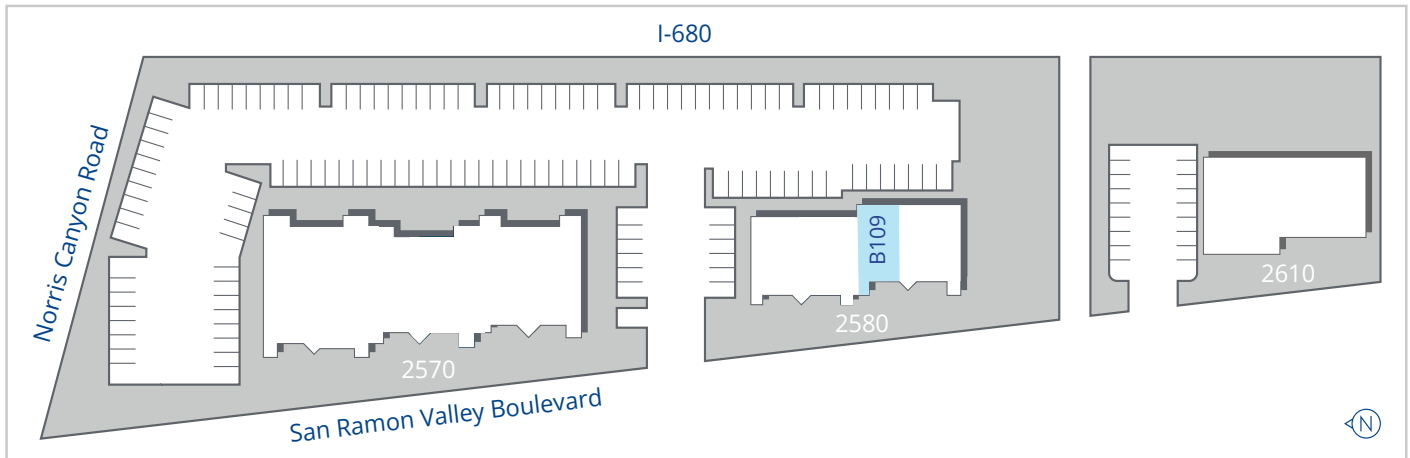

## Second Floor

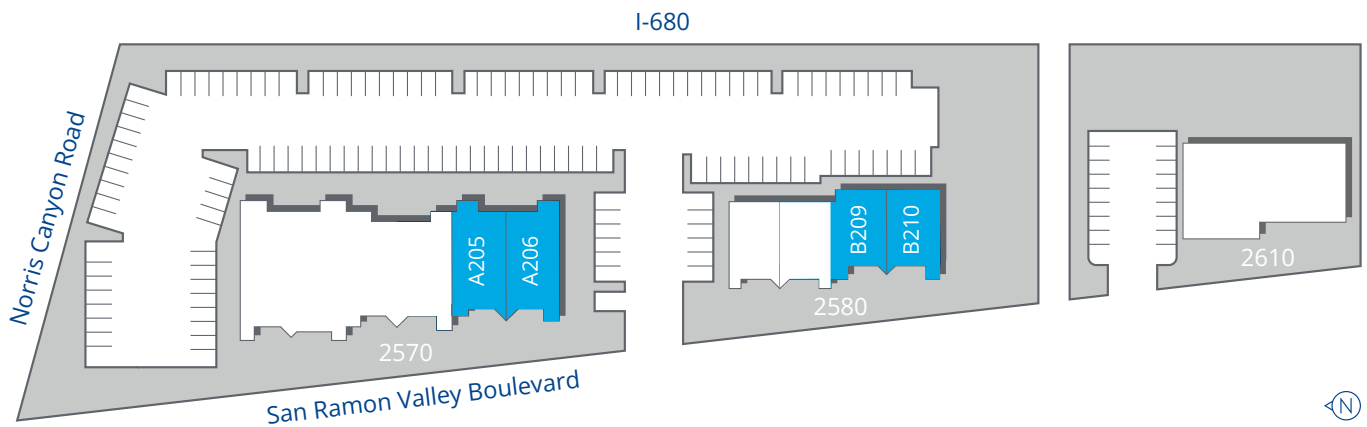

### 2570 San Ramon Valley Blvd

Suite	Type	SF NNN	Price PSF	OpEx
A205	Office	±1,560	\$1.00	\$0.46
A206	Office	±1,560	\$1.00	\$0.46

### 2580 San Ramon Valley Blvd

Suite	Type	SF NNN	Price PSF	OpEx
B209	Office	±1,170	\$1.00	\$0.46
B210	Office	±1,170	\$1.00	\$0.46
B109	Flex	±1,150	\$1.60	\$0.46

For Lease

# 2570 San Ramon Valley Blvd Suite A206

## Suite Features

- ±1,560 SF
- Office Space
- Asking: \$1.00 PSF/mo
- OpEx: \$0.46 PSF

## Site Plan | Second Floor

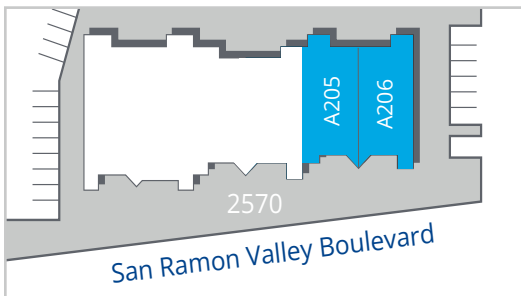

## Contact Brokers

### George Wineinger

Senior Vice President  
CA License No. 00878573  
george.wineinger@colliers.com  
+1 925 227 6214  
+1 925 963 6569

### Steve Tovani

Senior Vice President  
CA License No. 00890879  
steve.tovani@colliers.com  
+1 925 639 7002

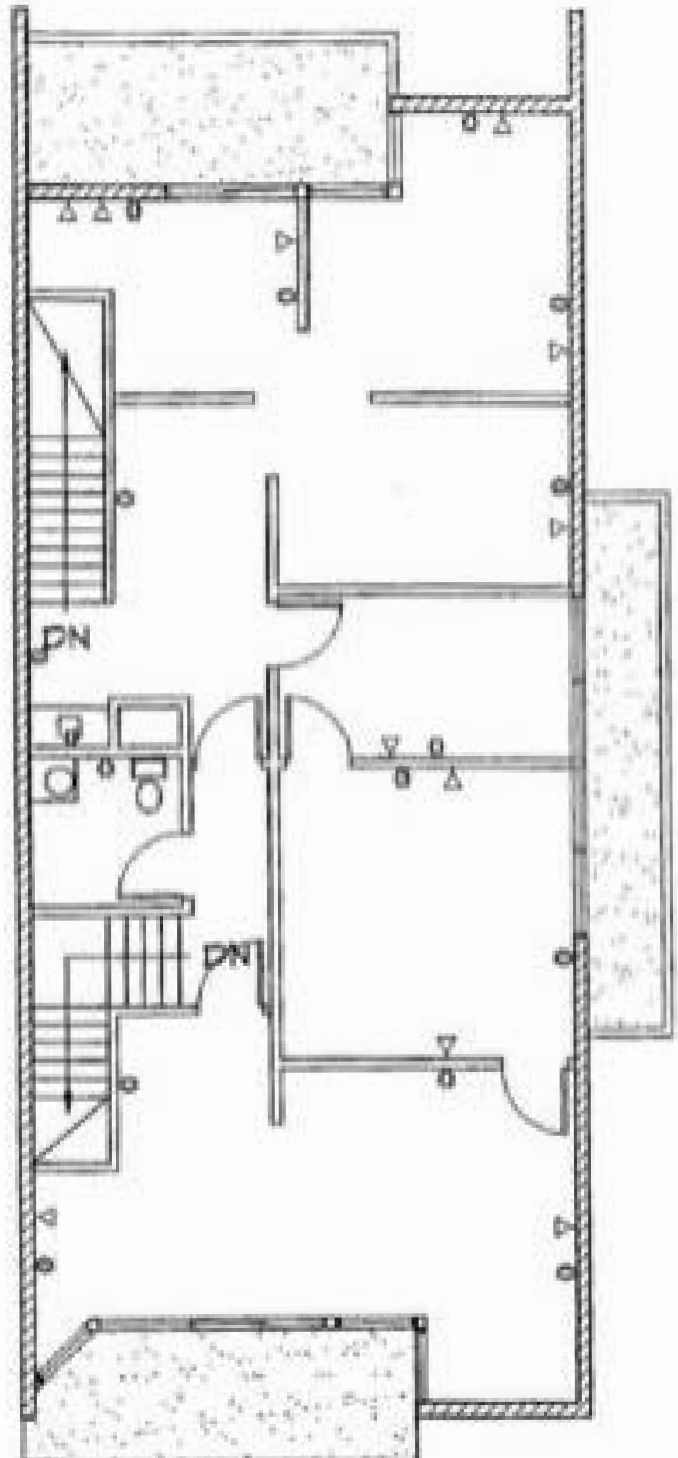

For Lease

# 2580 San Ramon Valley Blvd Suite B210

## Suite Features

- ±1,170 SF
- Office Space
- Asking: \$1.00 PSF/mo
- OpEx: \$0.46 PSF

## Site Plan | Second Floor

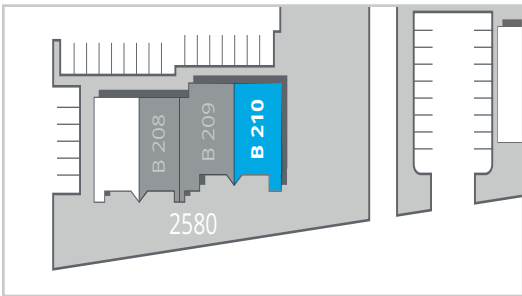

## Contact Brokers

### George Wineinger

Senior Vice President  
CA License No. 00878573  
george.wineinger@colliers.com  
+1 925 227 6214  
+1 925 963 6569

### Steve Tovani

Senior Vice President  
CA License No. 00890879  
steve.tovani@colliers.com  
+1 925 639 7002

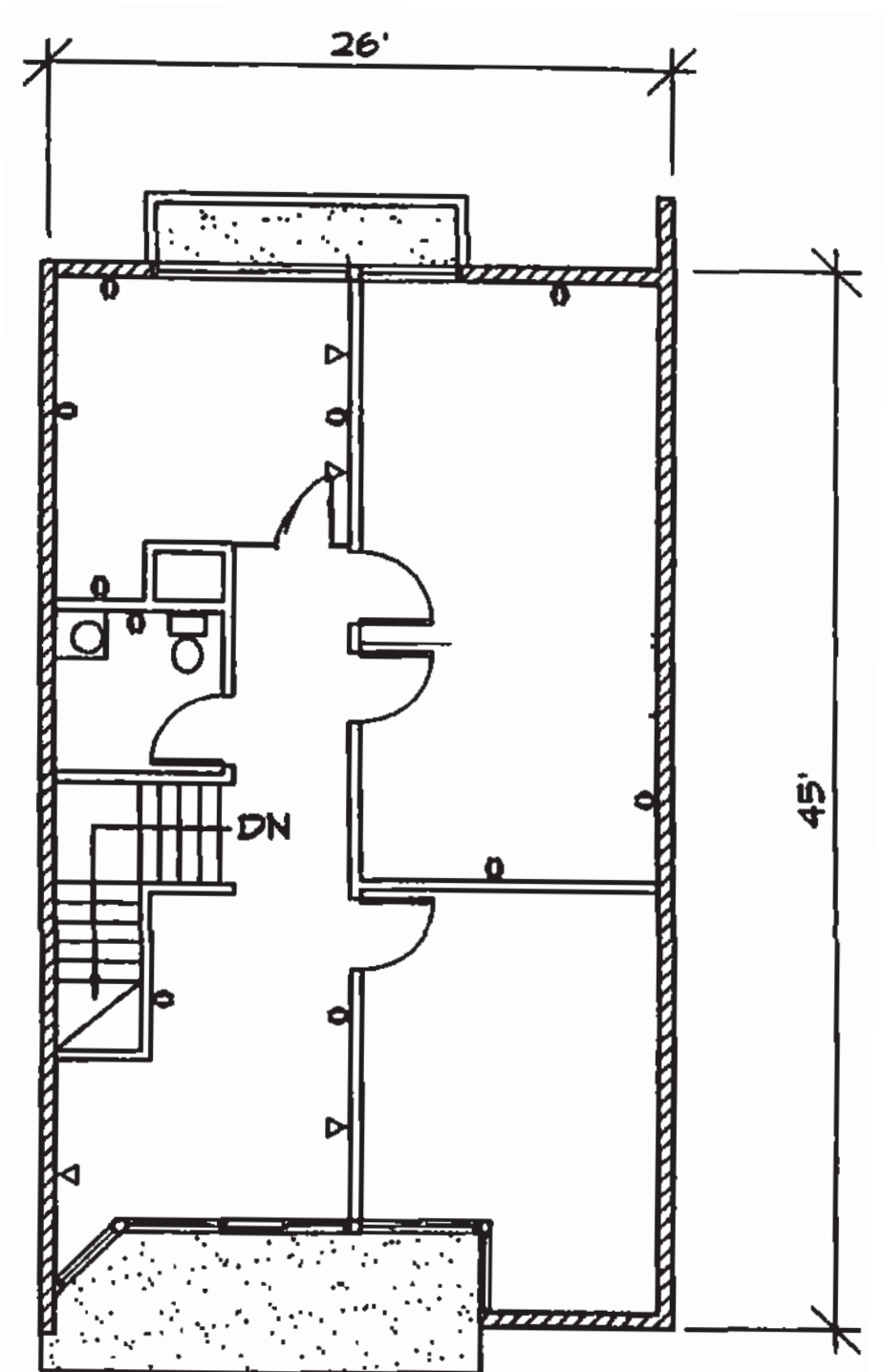

For Lease

# 2580 San Ramon Valley Blvd Suite B109

## Suite Features

- ±1,150 SF
- Office Space
- Asking: \$1.60 PSF/mo
- OpEx: \$0.46 PSF

## Site Plan | Second Floor

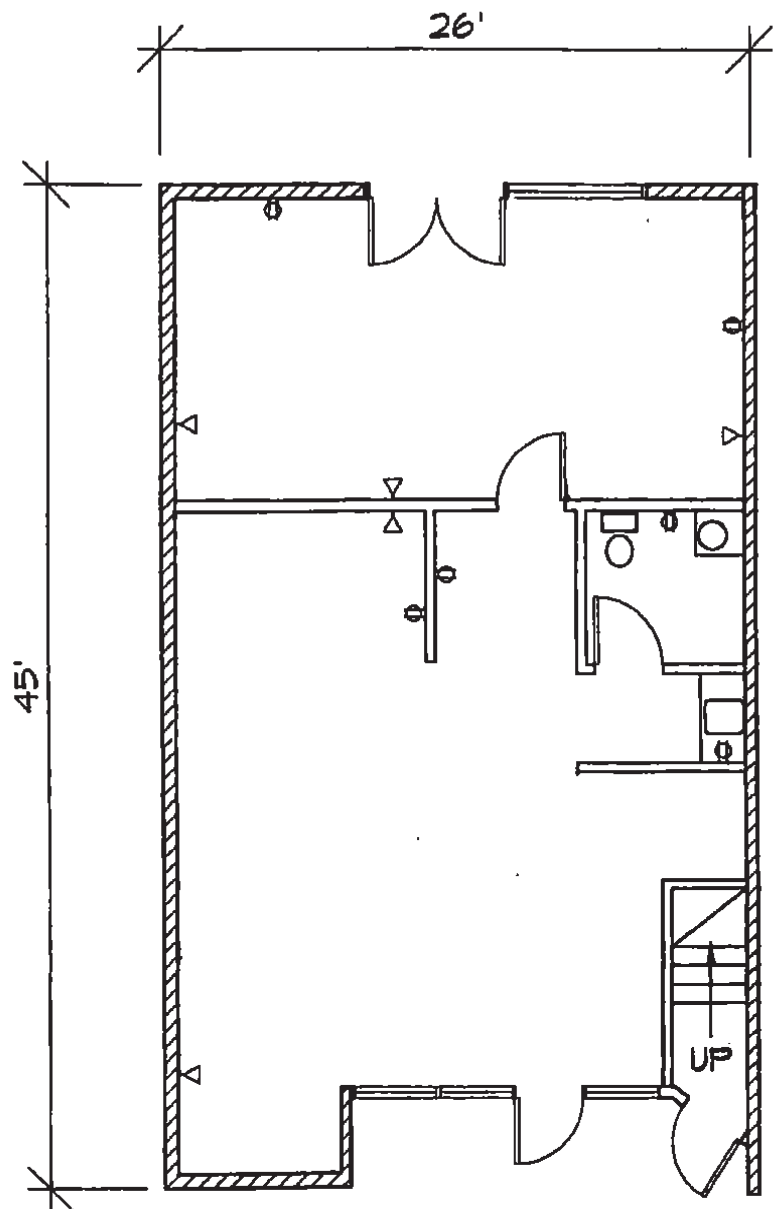
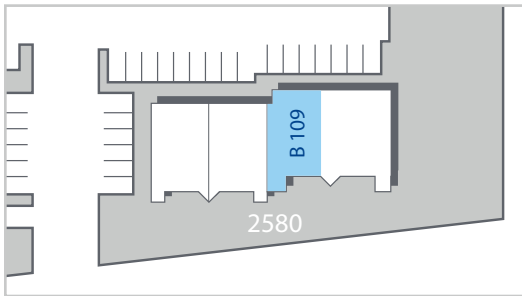

## Contact Brokers

### George Wineinger

Senior Vice President  
CA License No. 00878573  
george.wineinger@colliers.com  
+1 925 227 6214  
+1 925 963 6569

### Steve Tovani

Senior Vice President  
CA License No. 00890879  
steve.tovani@colliers.com  
+1 925 639 7002

2570 & 2580 San Ramon Valley Boulevard

# Photo Gallery

