

Cascade Corporate Center
Worthington, OH 43085

For Sale /
For Lease



Professional office suites with free athletic club

Sale Price: Call agents

Cascade I: 130 E Wilson Bridge Rd

Cascade II: 150 E Wilson Bridge Rd

Cascade V: 250 E Wilson Bridge Rd

Lease Rate: \$9.95 PSF Net

2024 Projected Operating Expenses:

Cascade I \$9.48 PSF

Cascade II \$8.67 PSF

Cascade V \$8.84 PSF

Available Space:

996 RSF to 31,319 RSF

- Excellent Worthington location in close proximity to restaurants, services and shopping
- Convenient access to I-270, I-71, SR 315 and SR 23
- Lighted parking (4.1/1,000), vending area with seating, outdoor patio, storage, 24/7 key card access
- Athletic club in complex, free to tenants, offering handball/racquetball courts, exercise/cardio equipment, lockers, and sauna/showers
- Conference center for tenant use (accommodates 30)



Jackson Pulliam
614.545.4097
jpulliam@AlterraRE.com

Richard Conie
614.545.4099
rconie@AlterraRE.com

Alterra Real Estate
614.365.9000
www.AltterraRE.com

Cascade Corporate Center

Available Space for Lease

Cascade I - 130 E Wilson Bridge Road

Floor	Suite	RSF	Comments
Terrace	75	1,225	
First	100	4,429	
	140	2,757	
	150	9,138	*Up to 17,995 SF on First Floor
Second	200	8,135	*Entire Second Floor Available: 16,995 SF
	210	3,085	
	250	5,674	*Large suite directly off lobby
Third	300	2,082	
	308	1,142	*Suite 308/310 can be combined for 2,667 SF or up to 4,749 SF if you add Suite 300 (2,082SF)
	310	1,525	
	320	1,856	
	325	3,692	

*Total Contiguous Available: 44,740 SF

Cascade II - 150 E Wilson Bridge Road

Floor	Suite	RSF	Comments
First	120	1,566	
	160	3,455	
Second	235	1,536	*Available 10/2025
	250	2,591	
Third	320	4,414	
	330	1,002	

Cascade V - 250 E Wilson Bridge Road

Floor	Suite	RSF	Comments
First	130	1,816	
	155	2,130	*Suites 155/175 Contiguous for 5,260 SF
	175	3,130	
	190	3,093	*Fully Furnished
Second	210	1,359	
	240	2,741	*Recently updated - can be combined with Suite 270
	270	1,760	

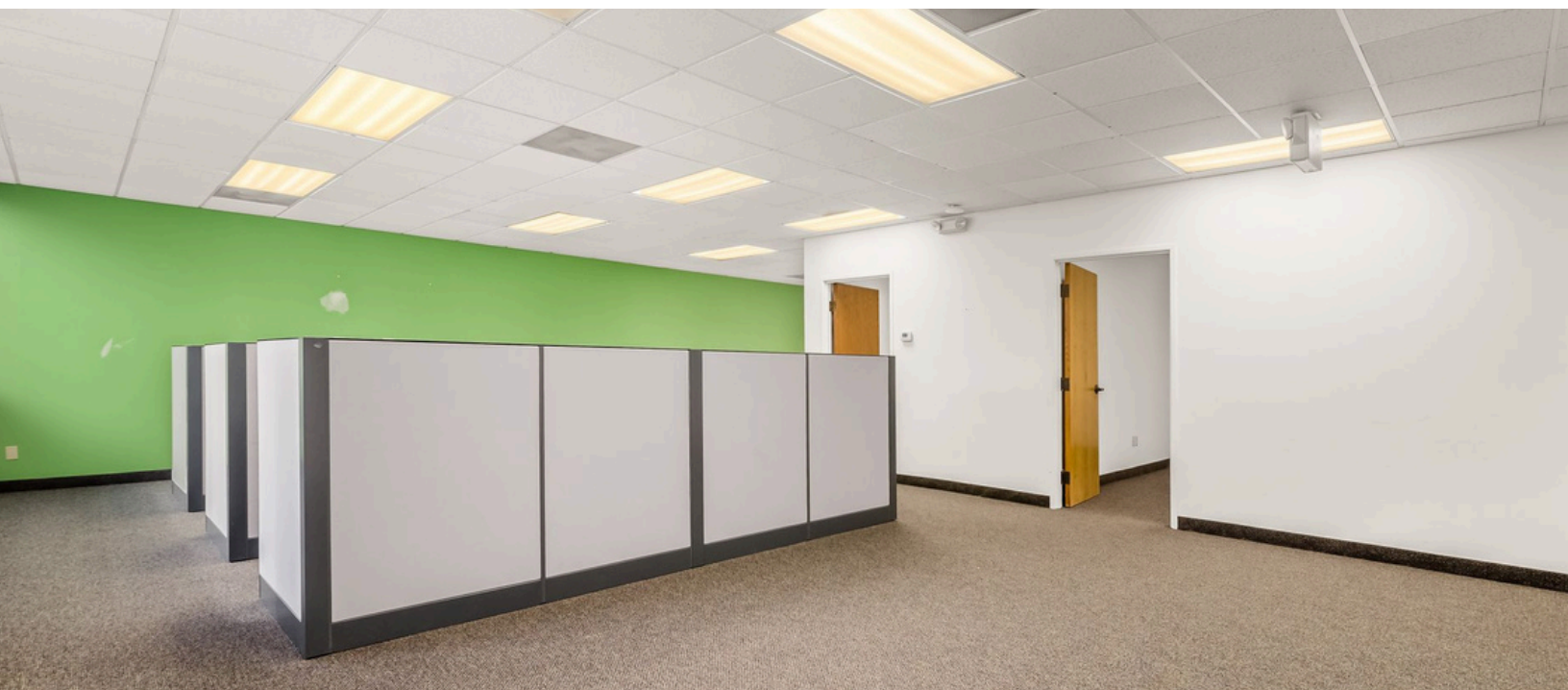





Cascade Corporate Center Worthington, OH 43085

For Lease

Location Facts & Demographics

Demographics are determined by a 10 minute drive from 150 E Wilson Bridge Rd, Columbus, OH 43085



CITY, STATE
Columbus, OH

POPULATION
131,621

AVG. HHSIZE
2.34

MEDIAN HH INCOME
\$68,103

HOME OWNERSHIP

Renters: **24,796**
Owners: **31,773**

EMPLOYMENT

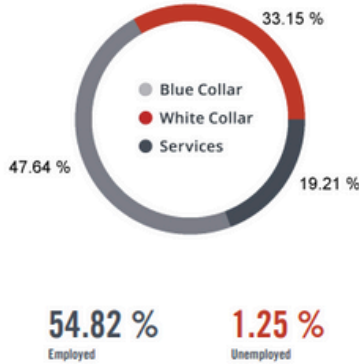

EDUCATION

High School Grad: **19.08 %**
Some College: **22.28 %**
Associates: **6.71 %**
Bachelors: **49.99 %**

GENDER & AGE

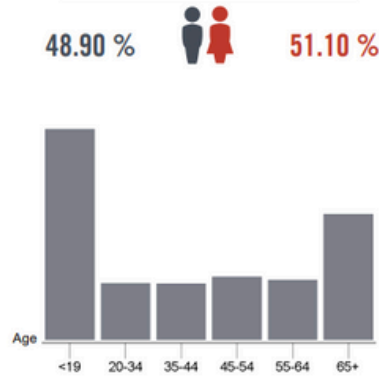

RACE & ETHNICITY

White: **90.44 %**
Asian: **3.17 %**
Native American: **0.01 %**
Pacific Islanders: **0.00 %**
African-American: **2.75 %**
Hispanic: **1.93 %**
Two or More Races: **1.69 %**

INCOME BY HOUSEHOLD

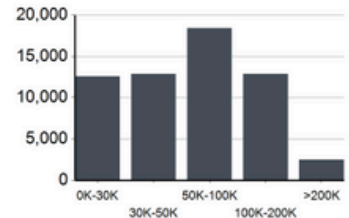

HH SPENDING

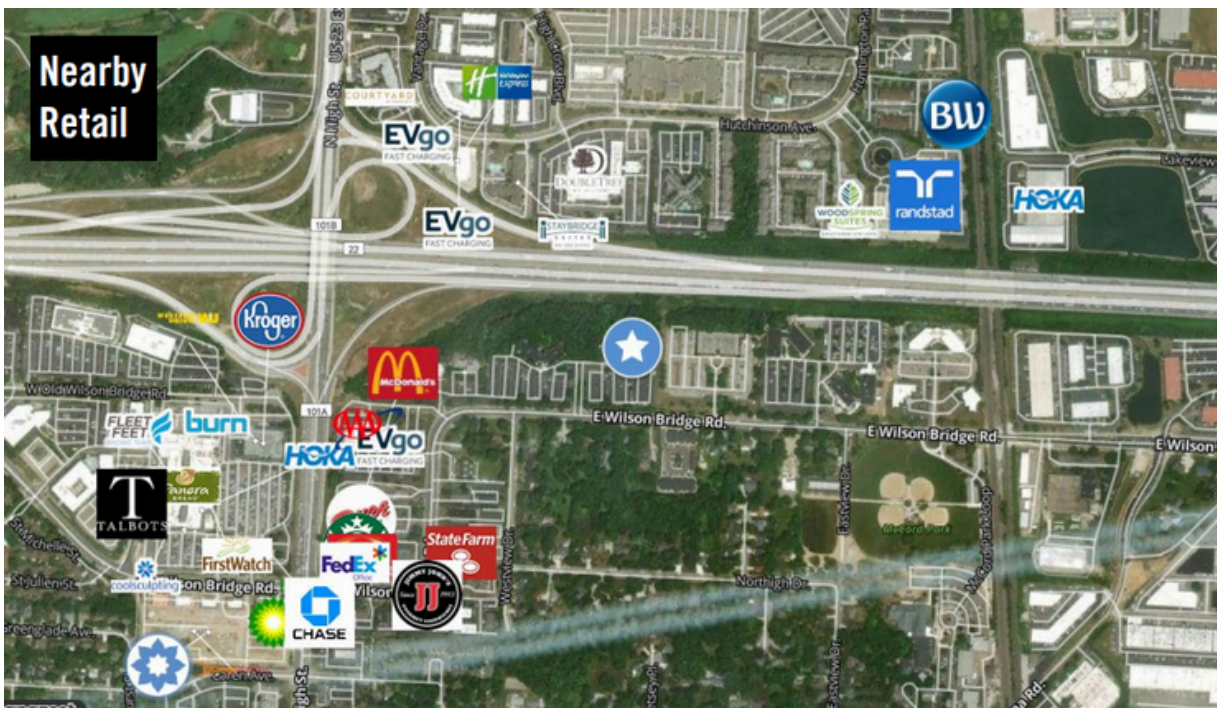
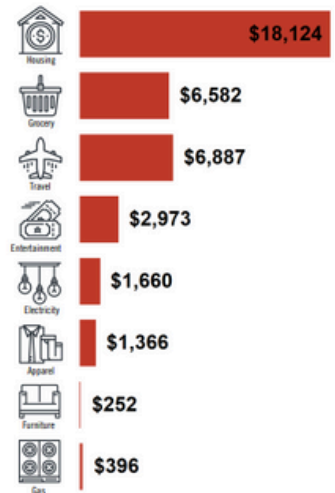

Jackson Pulliam
614.545.4097
jpulliam@AlterraRE.com

Richard Conie
614.545.4099
rconie@AlterraRE.com

Alterra Real Estate
614.365.9000
www.AltterraRE.com

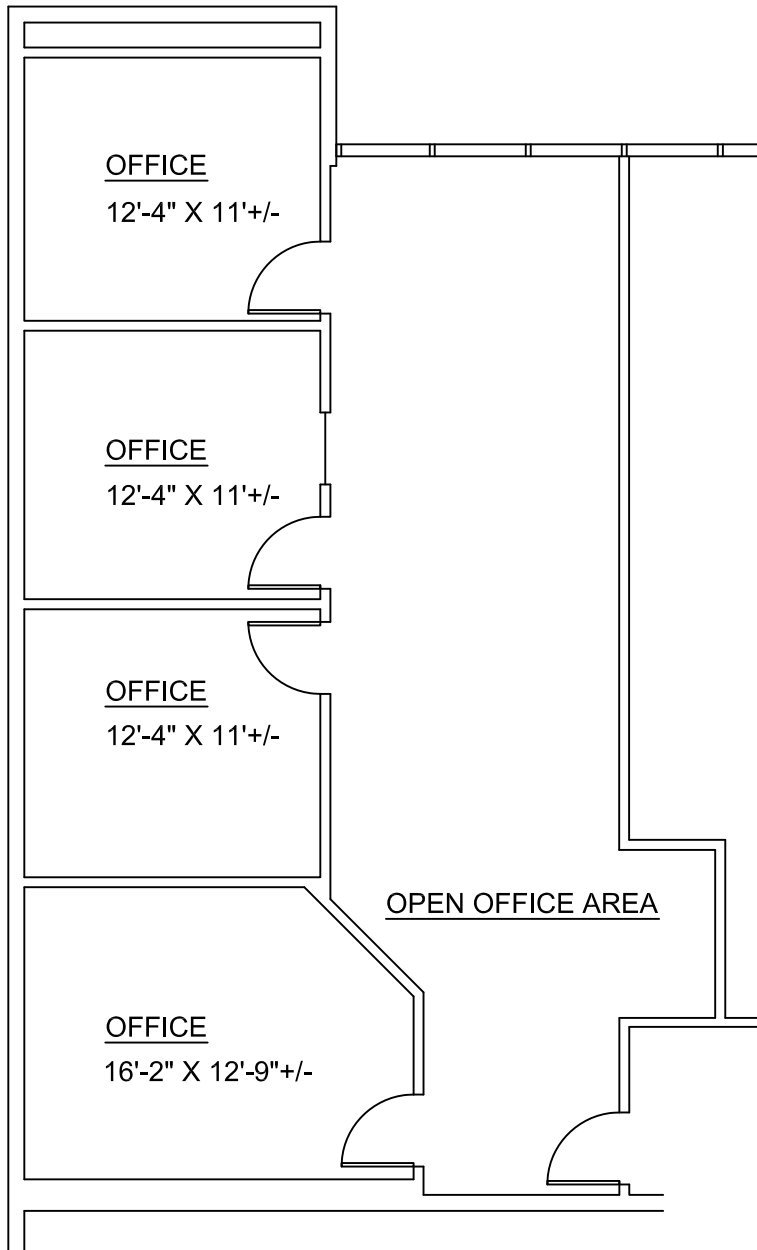

Cascade I - Suite 75

1,225 Sq. Ft. Scale 1/8" = 1' - 0"

Cascade Corporate Center

130 East Wilson Bridge Road - Terrace Level
 Worthington, Ohio

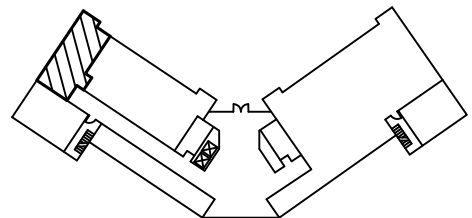

Terrace Level Key Plan

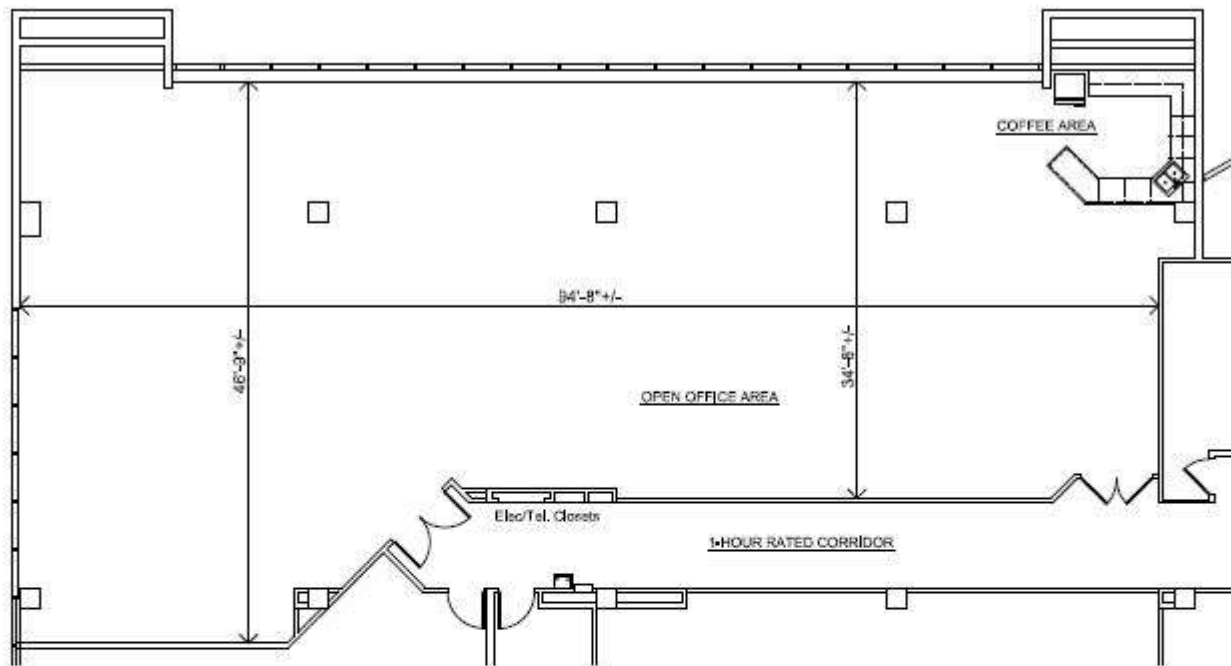

Cascade I - Suite 100

4,429 Square Feet Available Not to Scale

Cascade Corporate Center

130 East Wilson Bridge Road - First Floor
 Worthington, Ohio

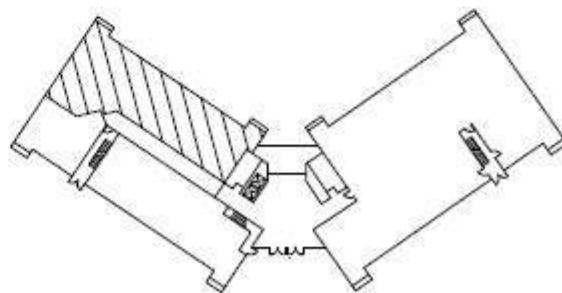

First Floor Key Plan

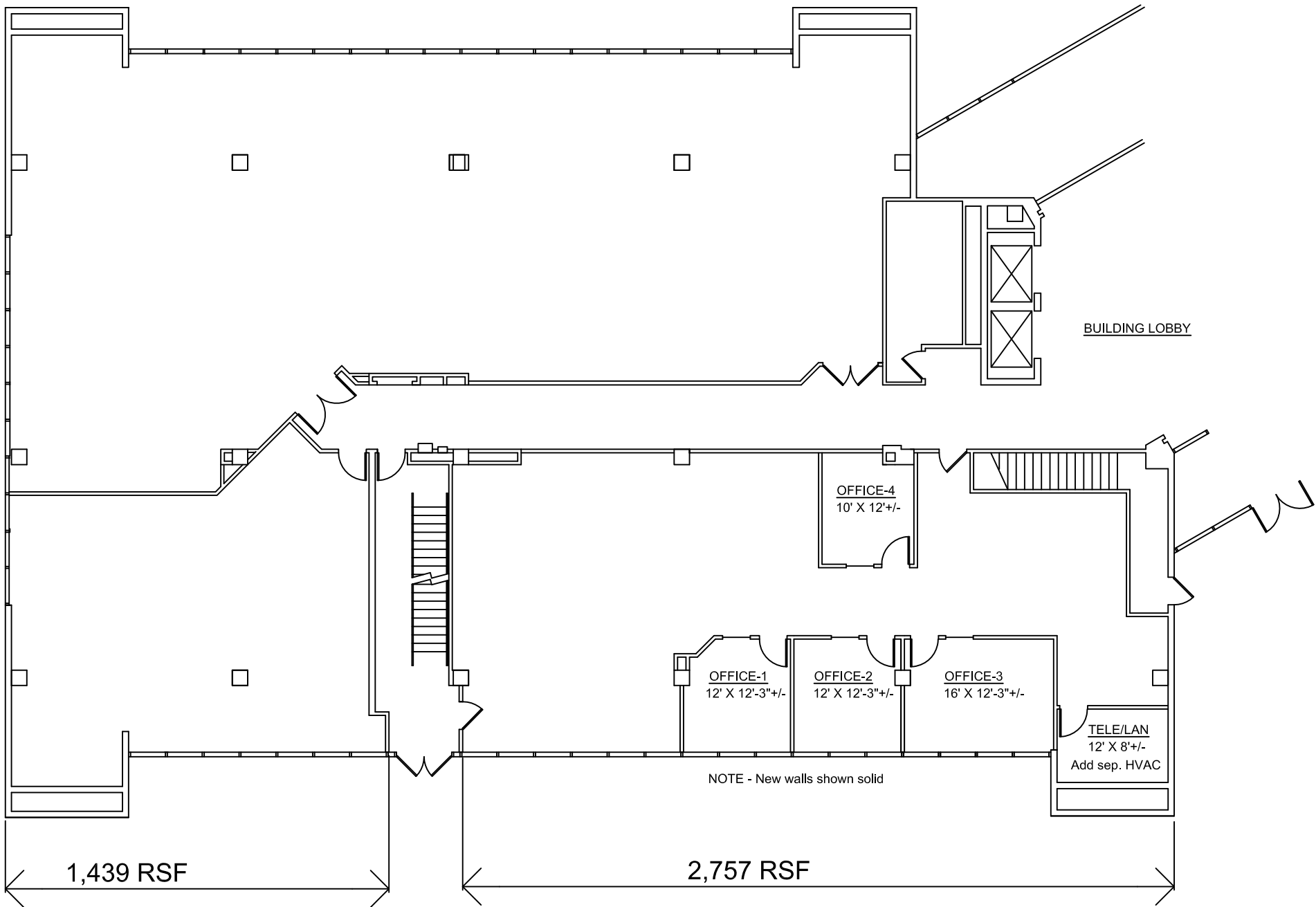

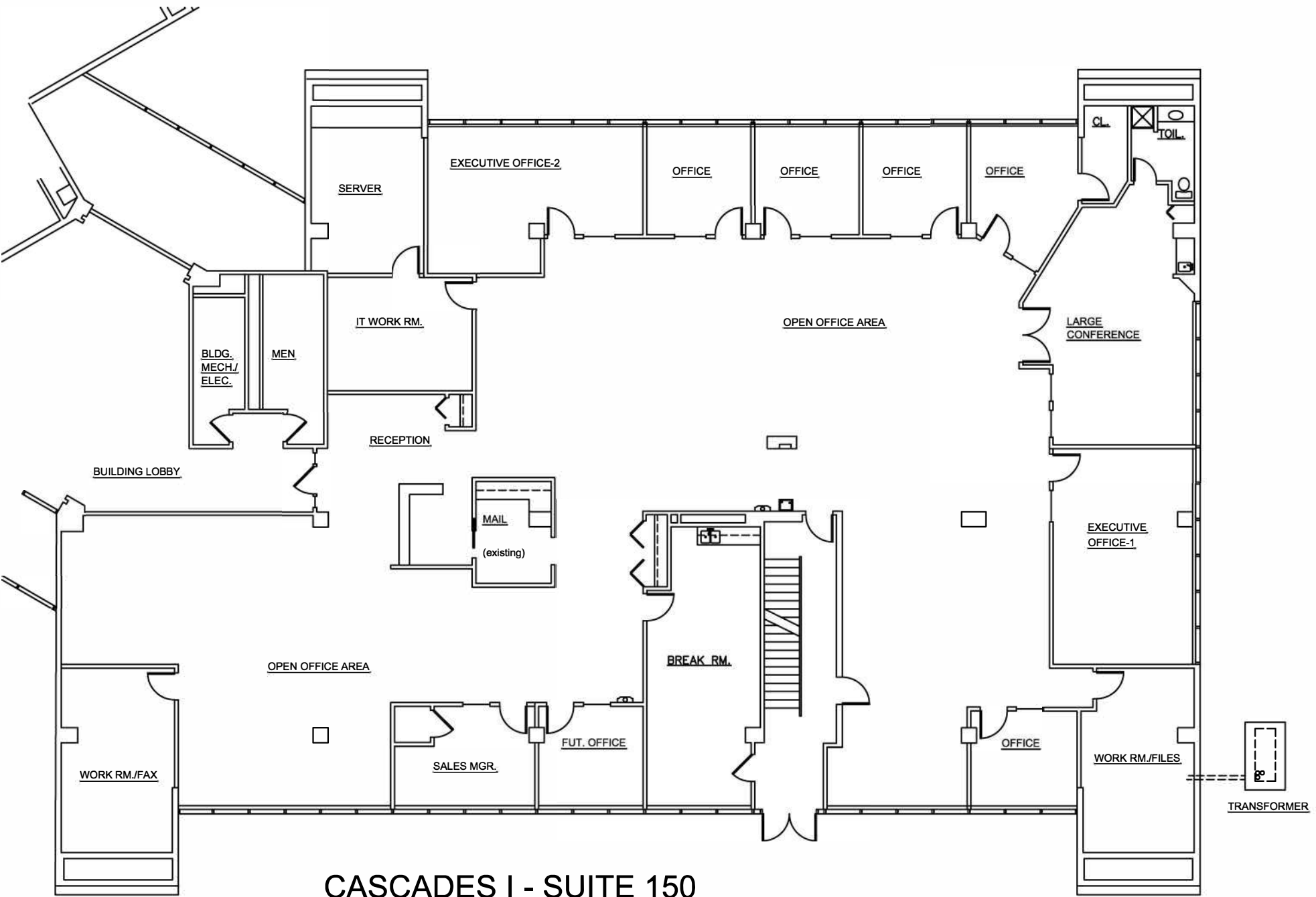

CASCADES I - SUITE 150
9,138 RSF

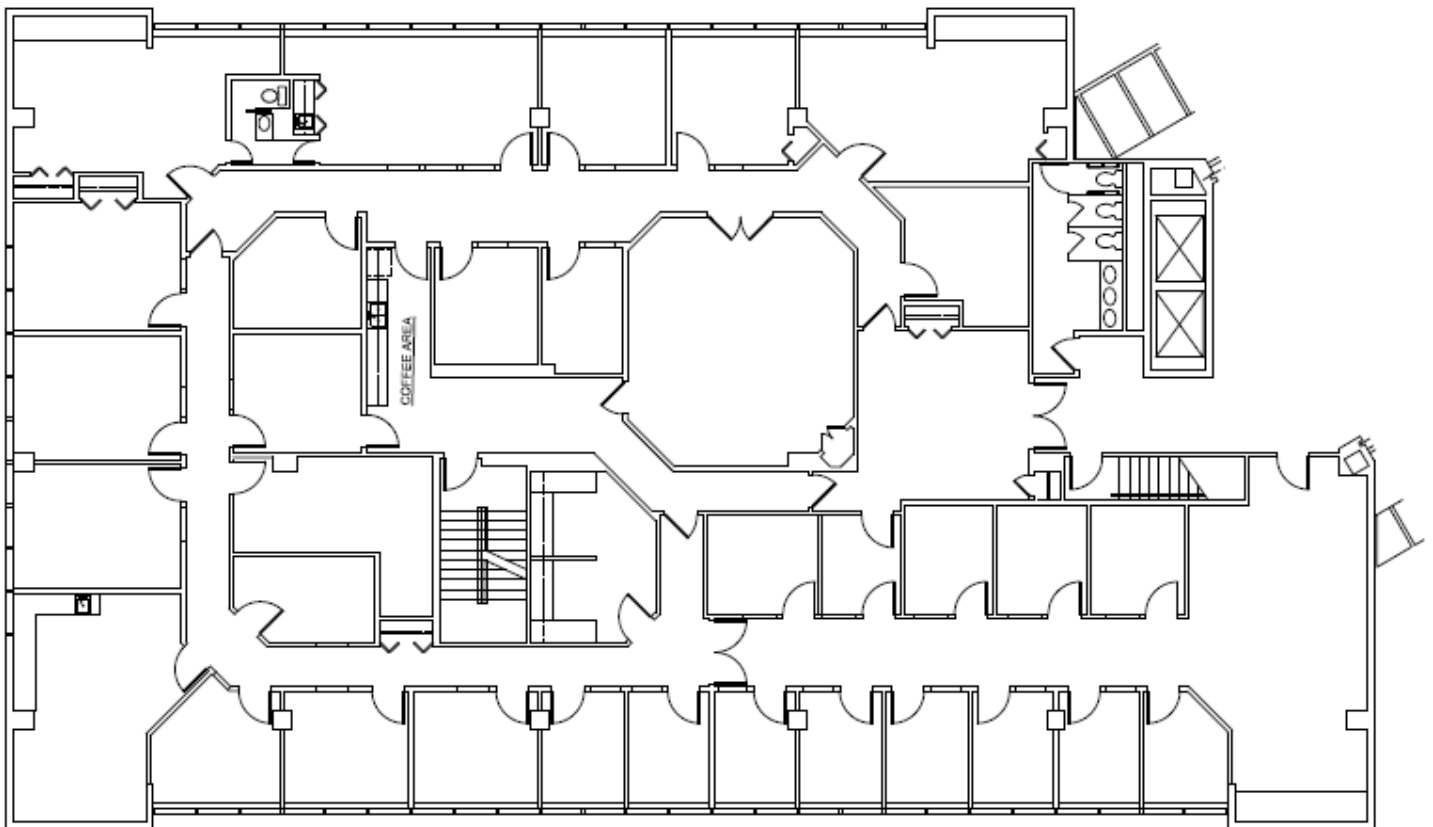

Cascade I - Suite 200

8,135 Square Feet Available Not to Scale

Cascade Corporate Center

130 East Wilson Bridge Road - Second Floor
Worthington, Ohio

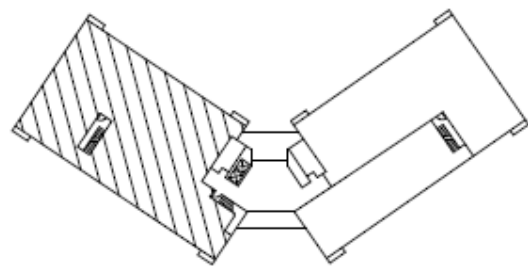

Second Floor Key Plan

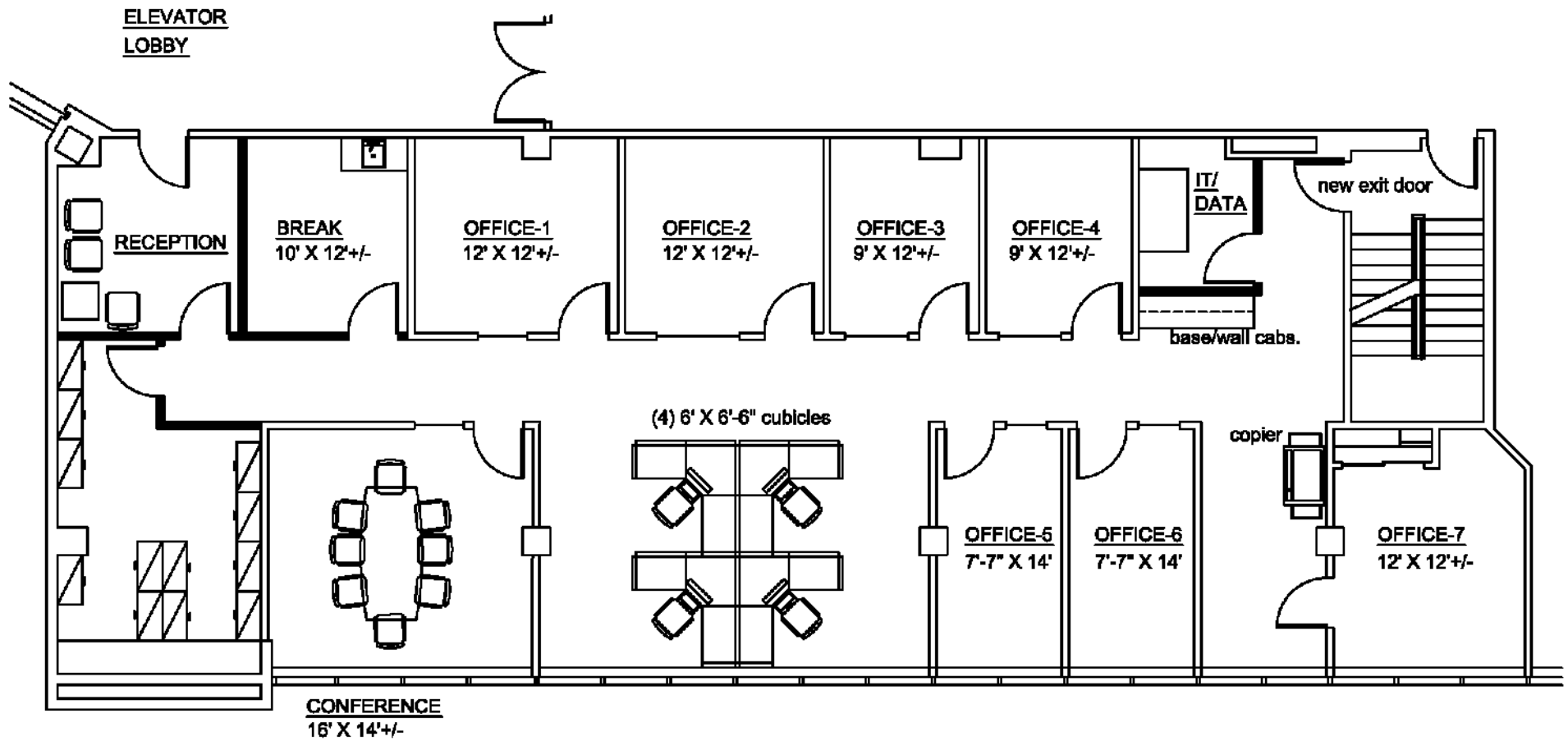

Cascade I - Suite 210

3,085 Sq. Ft. Total Available Not to Scale 09-27-17

Cascade Corporate Center

130 East Wilson Bridge Road - Second Floor
Worthington, Ohio

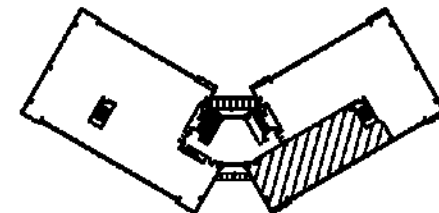

Second Floor Key Plan

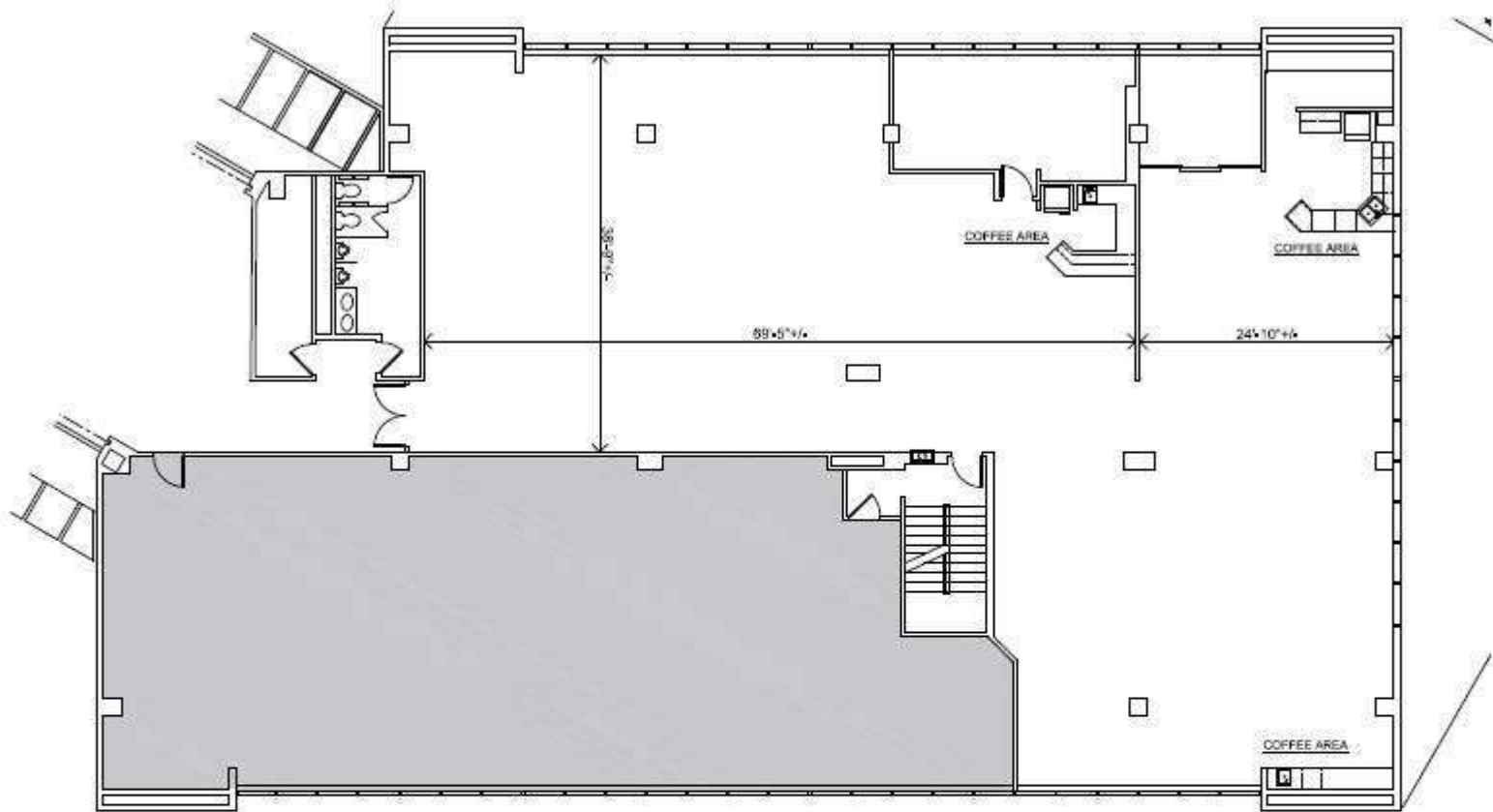

Cascade I - Suite 250

5,674 Square Feet Available Not to Scale

Cascade Corporate Center

130 East Wilson Bridge Road - Second Floor
Worthington, Ohio

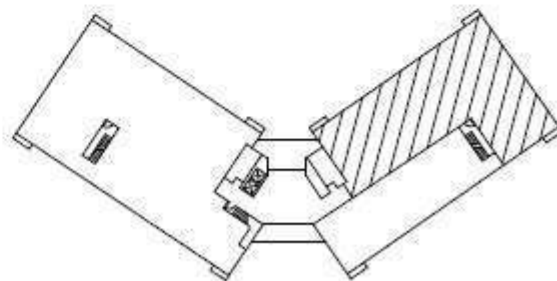

Second Floor Key Plan

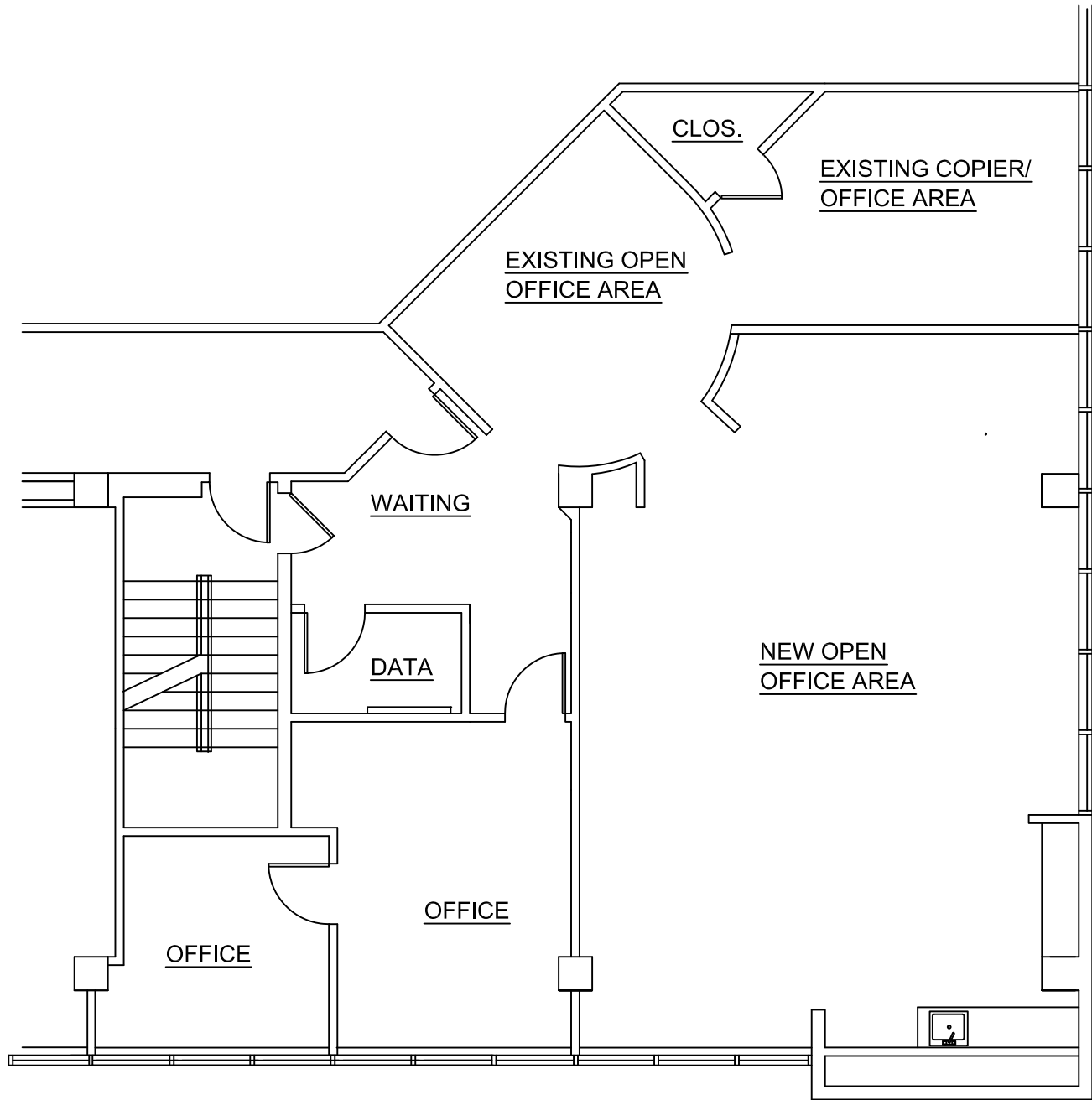

HOME CARE NETWORK

CASCADE I
130 E. WILSON BRIDGE RD. - SUITE 300
WORTHINGTON, OHIO

2,082 RSF

TOTAL COMBINED SUITES 308-310 - 2,667 SF RENTABLE AREA PER LEASE

SUITE 310

1,525 RSF

SUITE 308

1,142 RSF

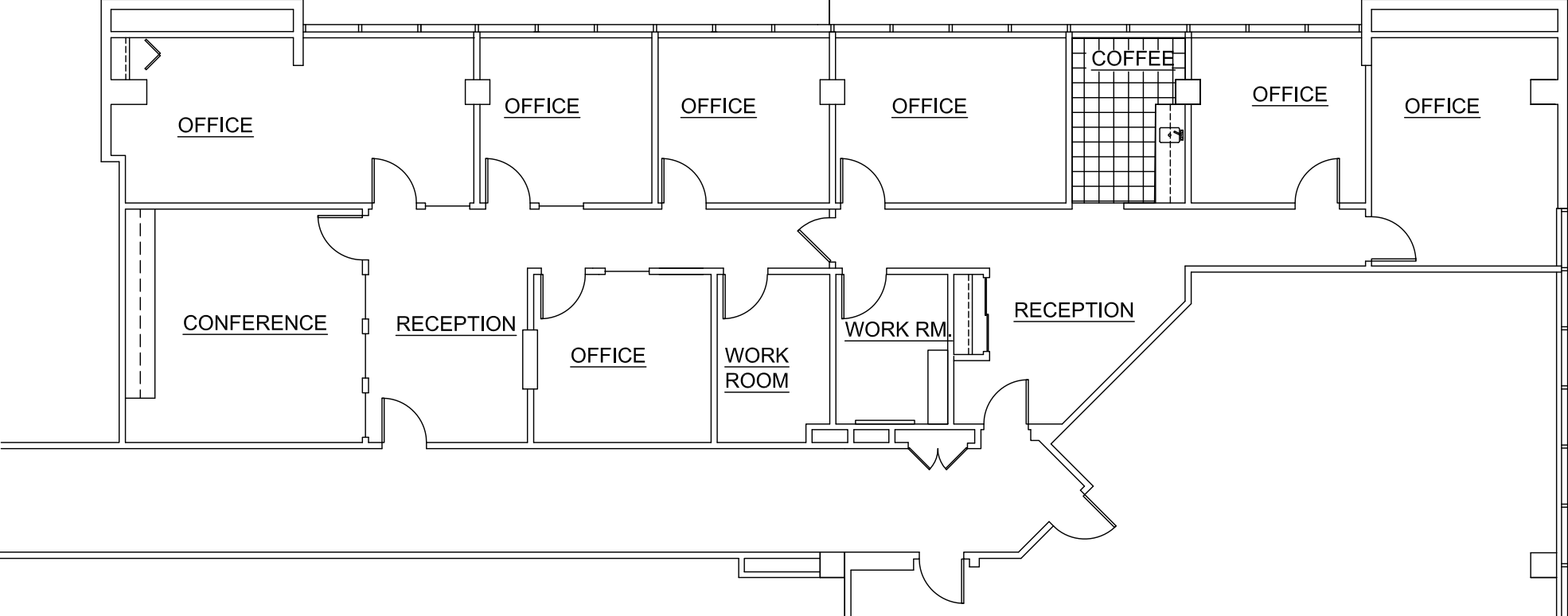

CASCADE I - S.308-310

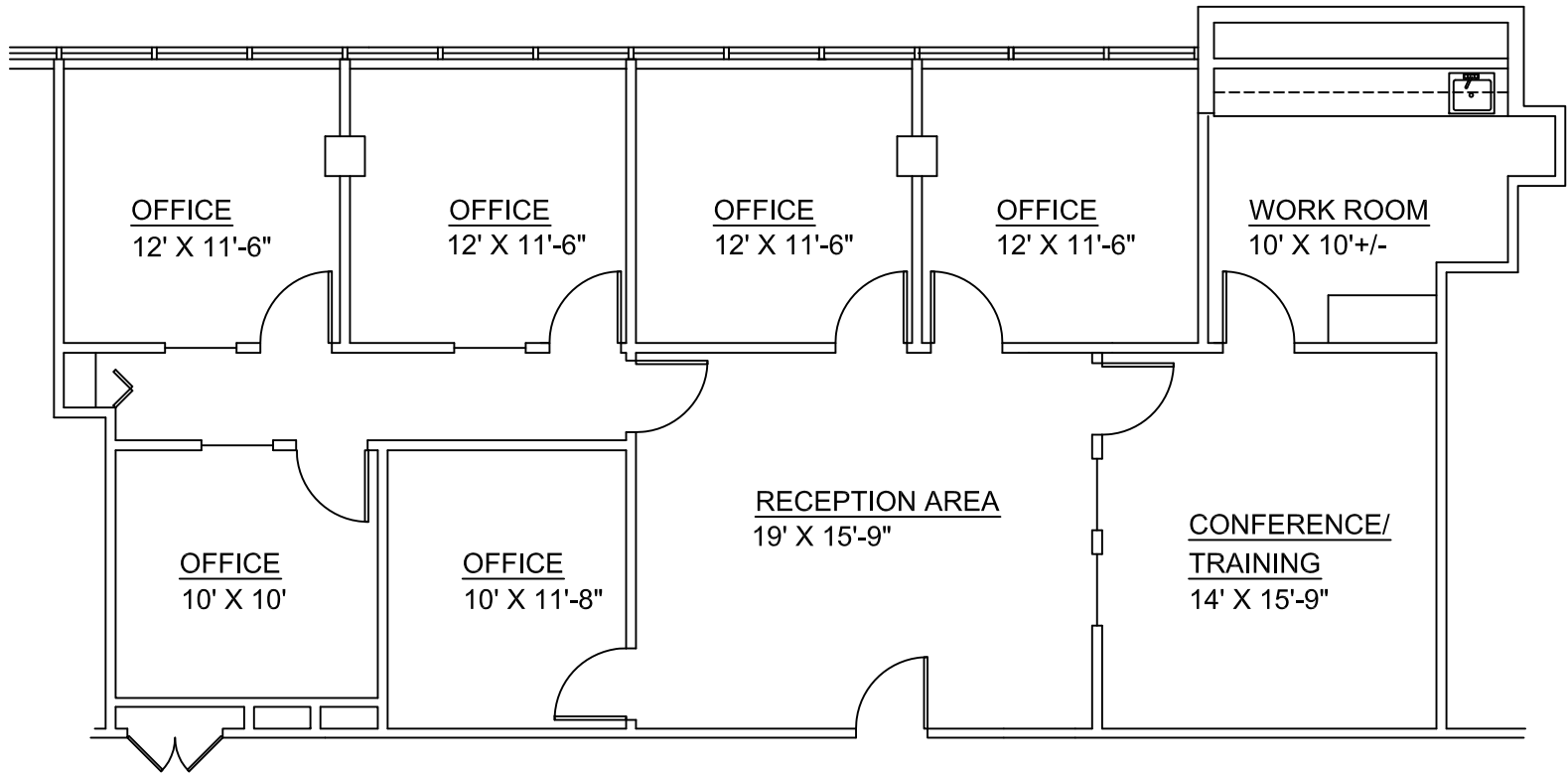

Cascade I - Suite 320

1,856 Sq. Ft. Scale 1/8" = 1' - 0"

Cascade Corporate Center

130 East Wilson Bridge Road - Third Floor
Worthington, Ohio

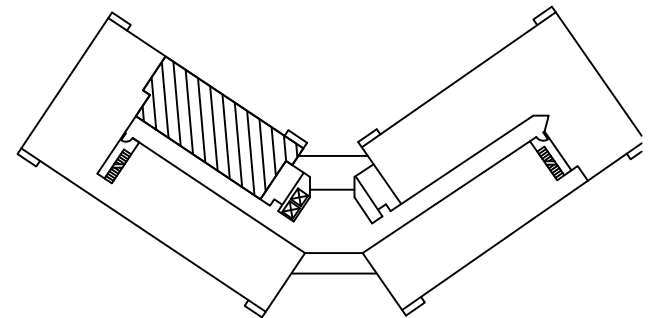

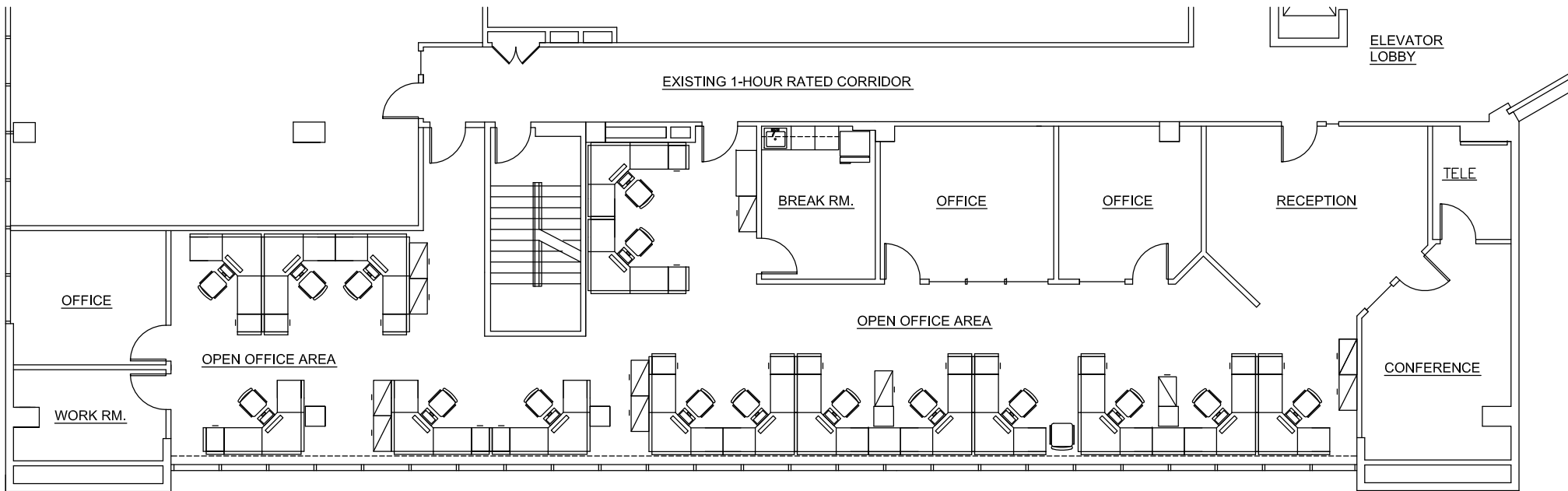

CASCADE I - SUITE 325 MODIS, INC. 3,692 RSF

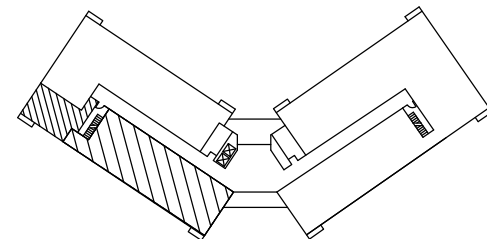

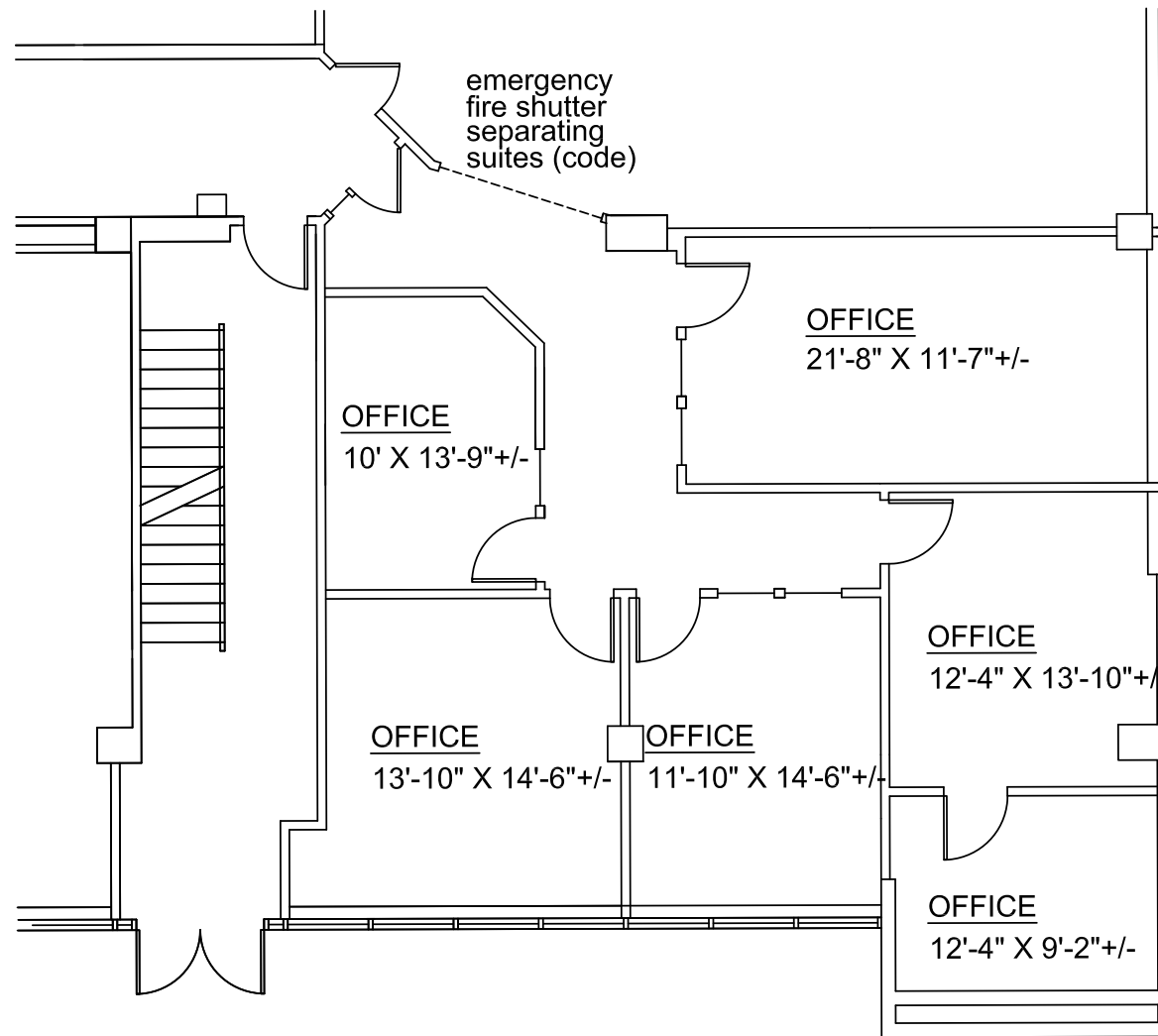

Cascade II - Suite 120

1,566 Square Feet Available Scale 1/8" = 1' - 0"

Cascade Corporate Center

150 East Wilson Bridge Road - First Floor
Worthington, Ohio

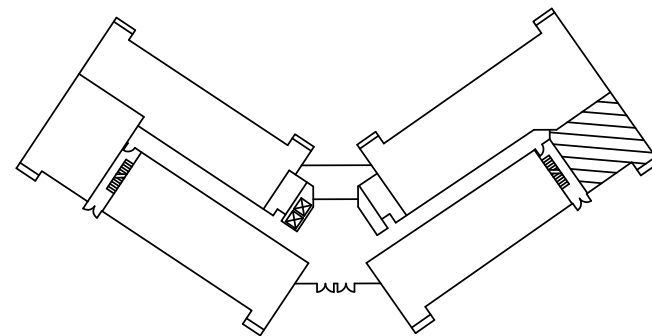

First Floor Key Plan

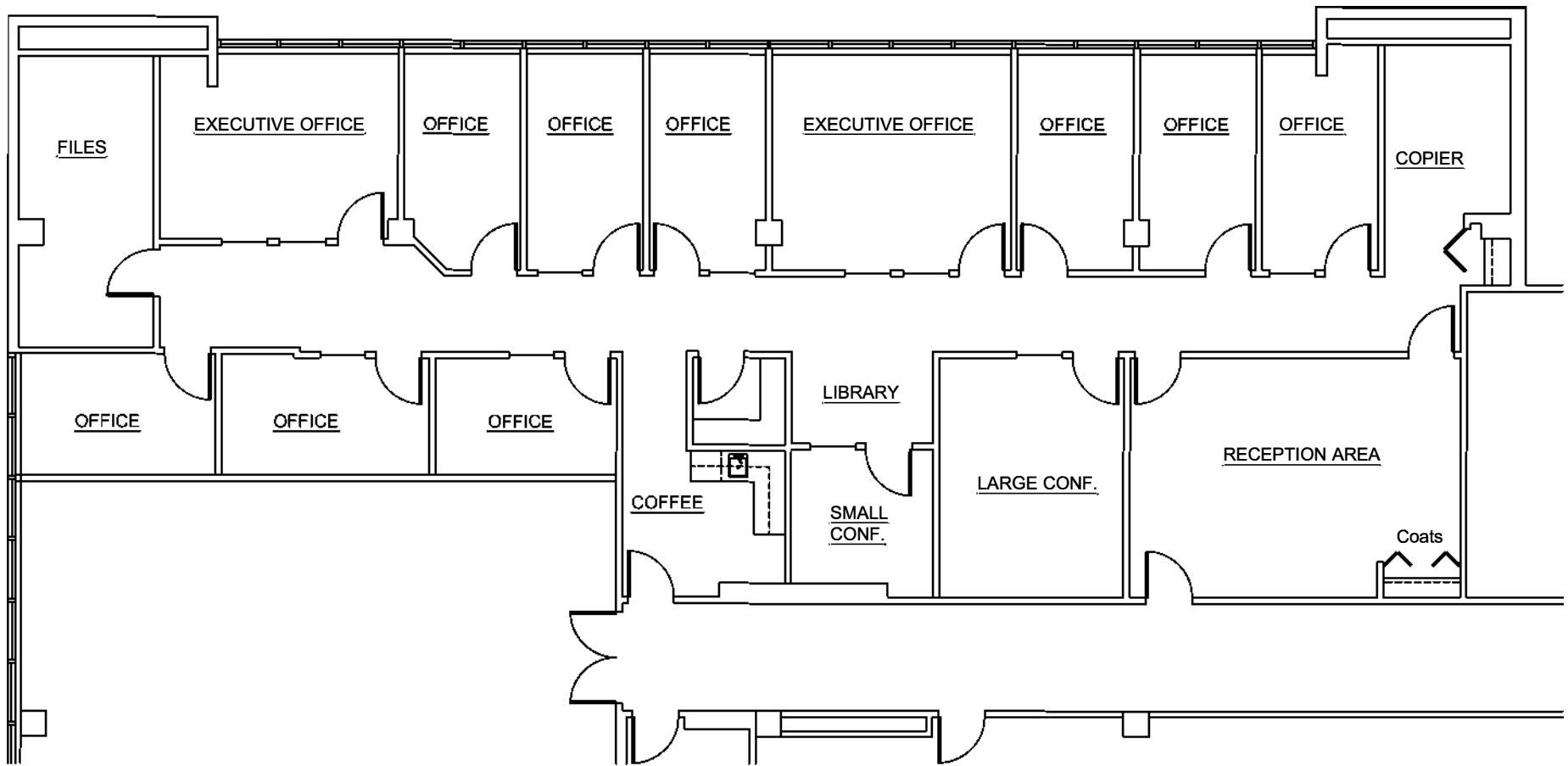

CASCADE II - SUITE 160

3,455 RSF

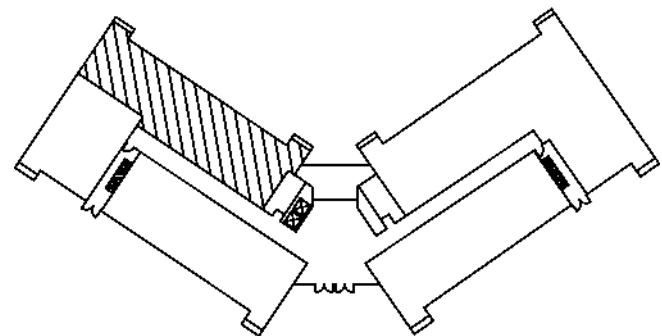

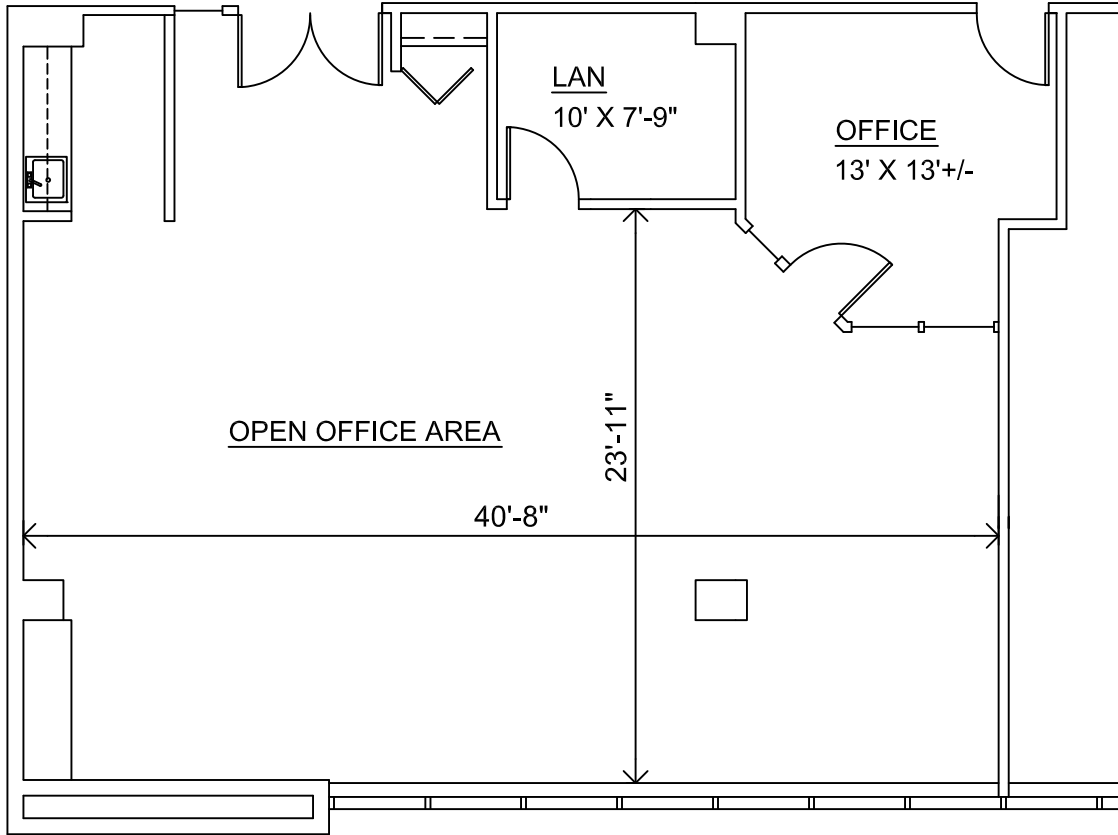

Cascade II - Suite 235

1,536 Sq. Ft. Scale 1/8" = 1' - 0"

Cascade Corporate Center

150 East Wilson Bridge Road - Second Floor
 Worthington, Ohio

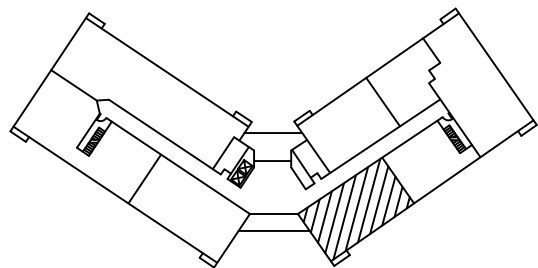

Second Floor Key Plan

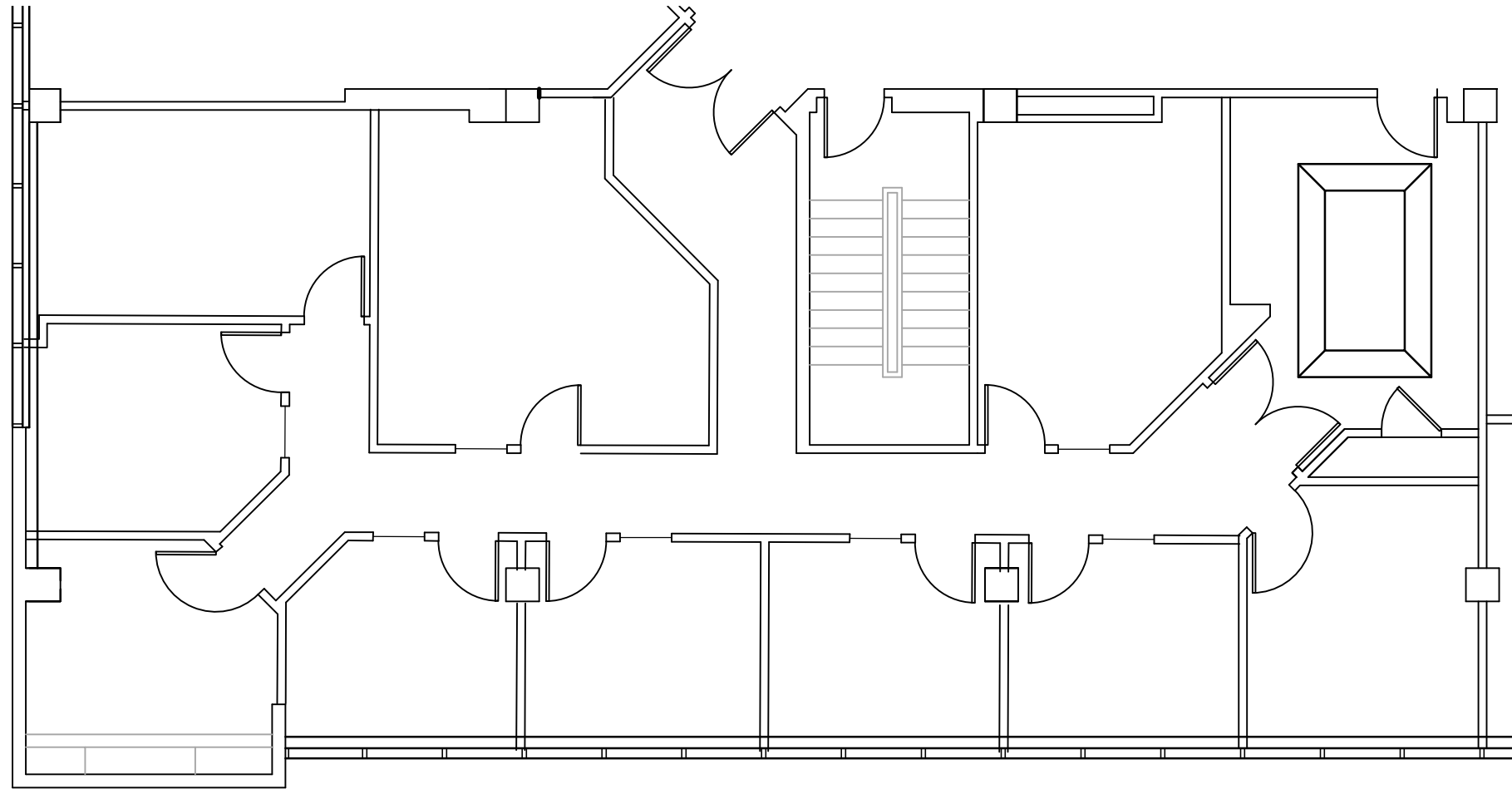

Suite 250

2,591 SF

1/8" = 1'-0"

Cascades II - 4,414 SF
Suite 320

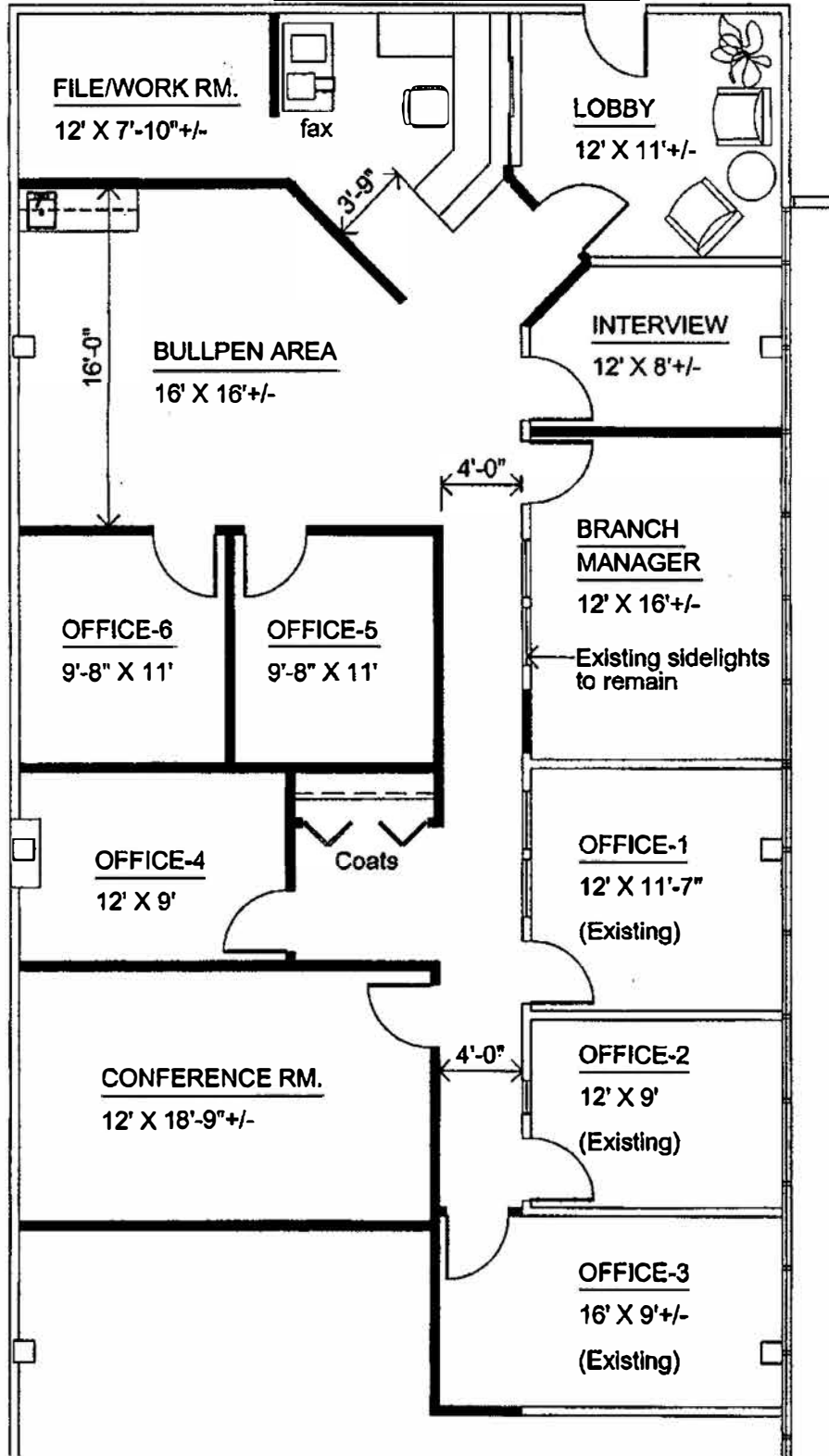

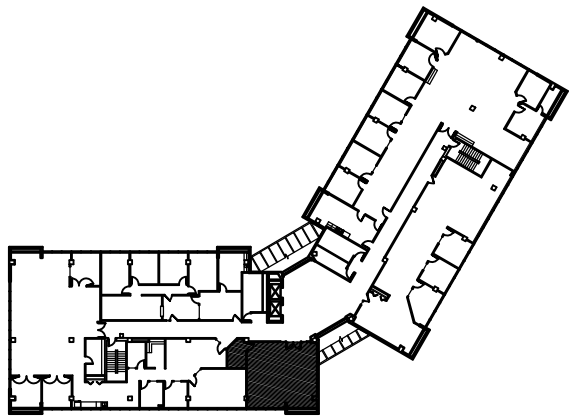
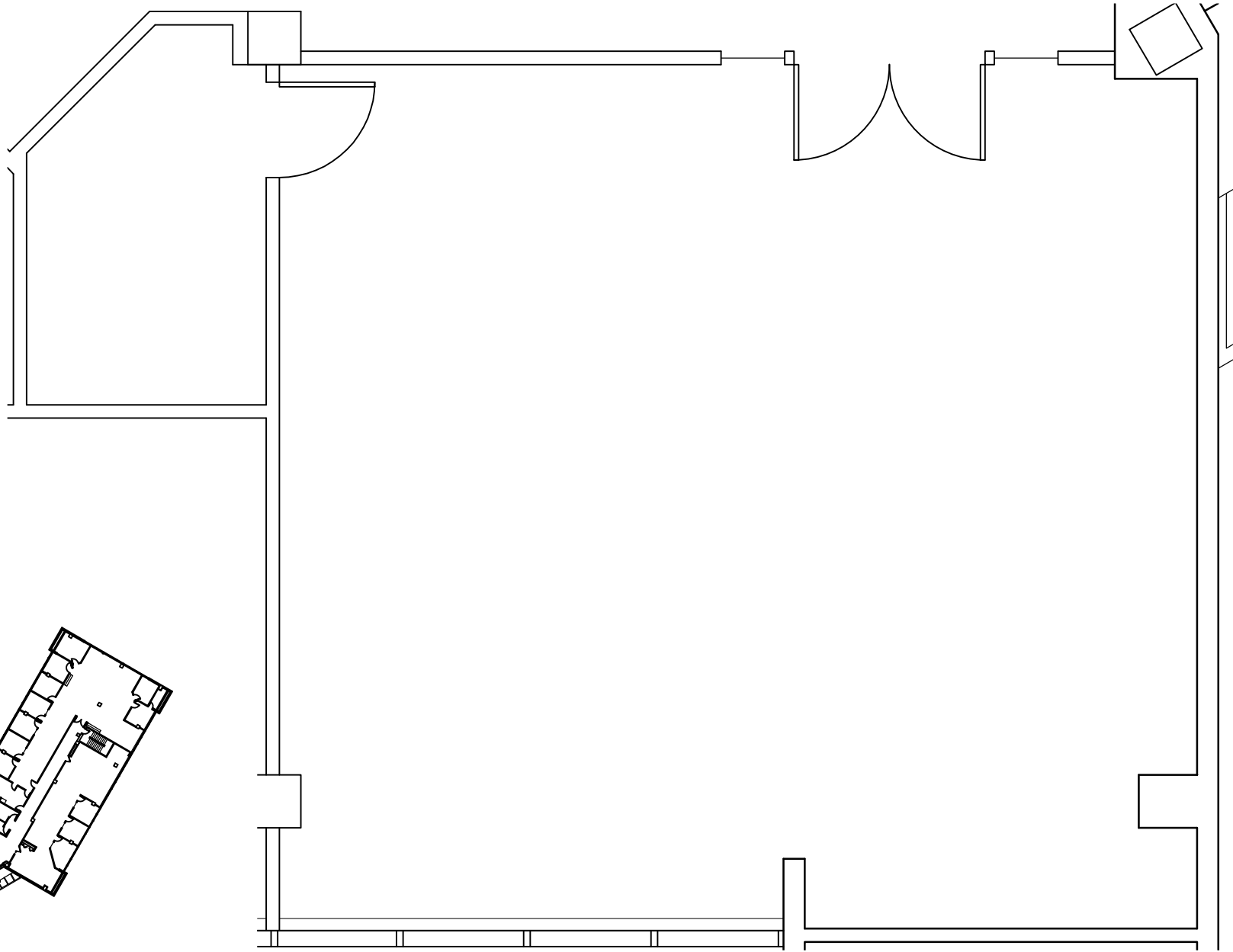

N building key plan

Third Floor

N.T.S.

Suite 330

150 E Wilson Bridge Road - Cascade II

N.T.S.

1,002 RSF.

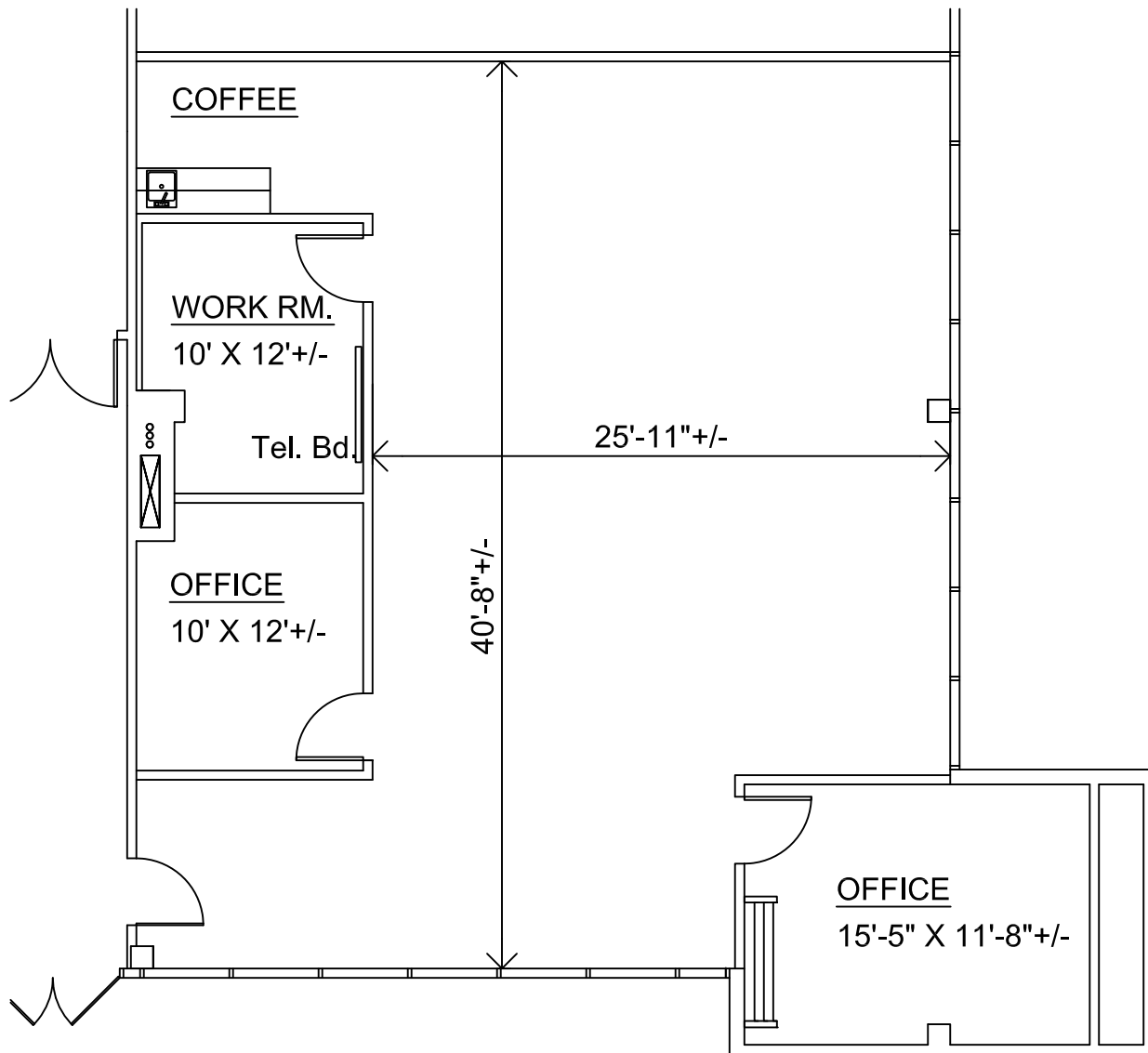

Cascade V - Suite 130

1,816 Sq. Ft. Scale 1/8" = 1' - 0"

Cascade Corporate Center

250 East Wilson Bridge Road - First Floor
 Worthington, Ohio

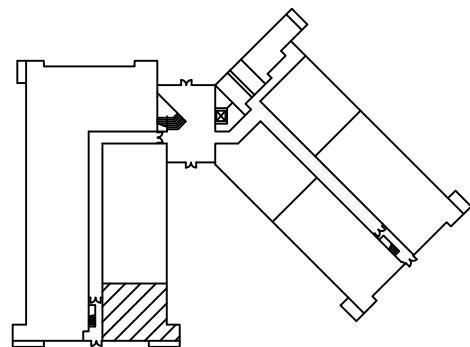

First Floor Key Plan

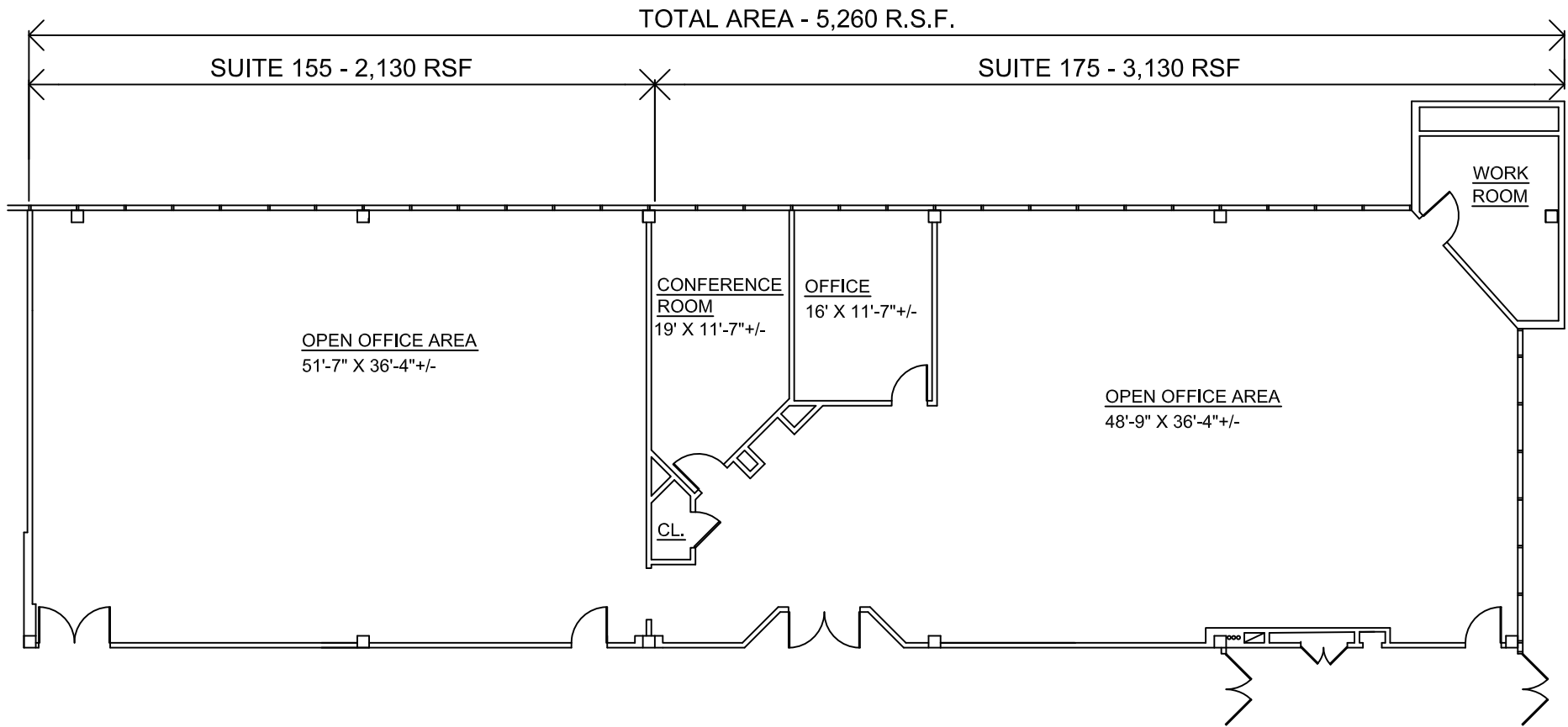

Cascade V - Suites 155-175

5,260 Sq. Ft. Total Available Not to Scale

Cascade Corporate Center

250 East Wilson Bridge Road - First Floor
Worthington, Ohio

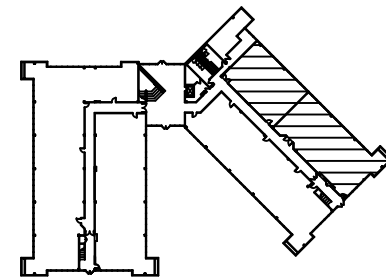

First Floor Key Plan

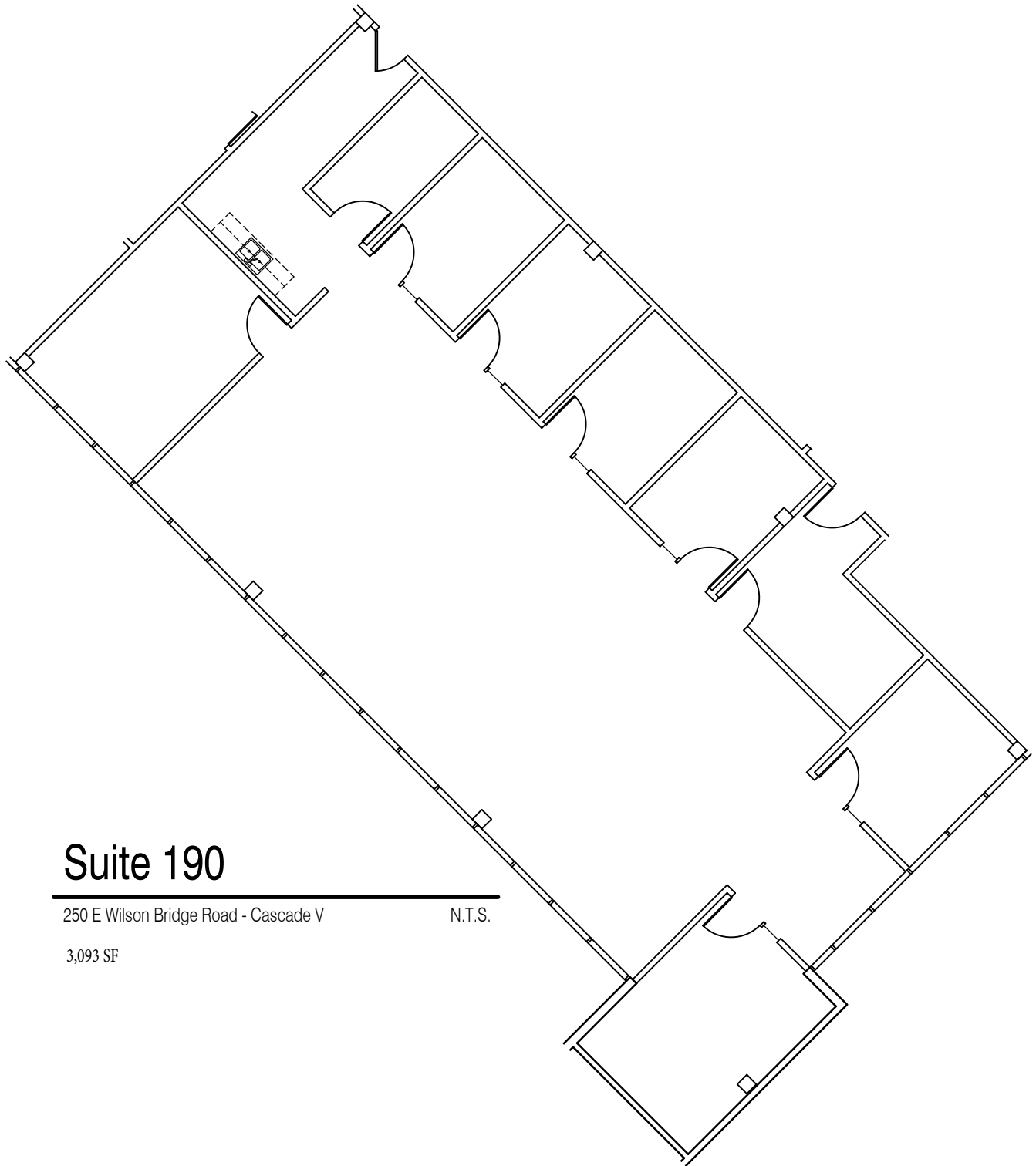

Suite 190

250 E Wilson Bridge Road - Cascade V

N.T.S.

3,093 SF

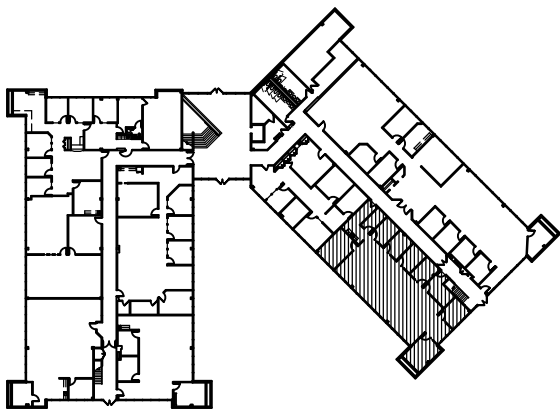

N building key plan

First Floor

N.T.S.

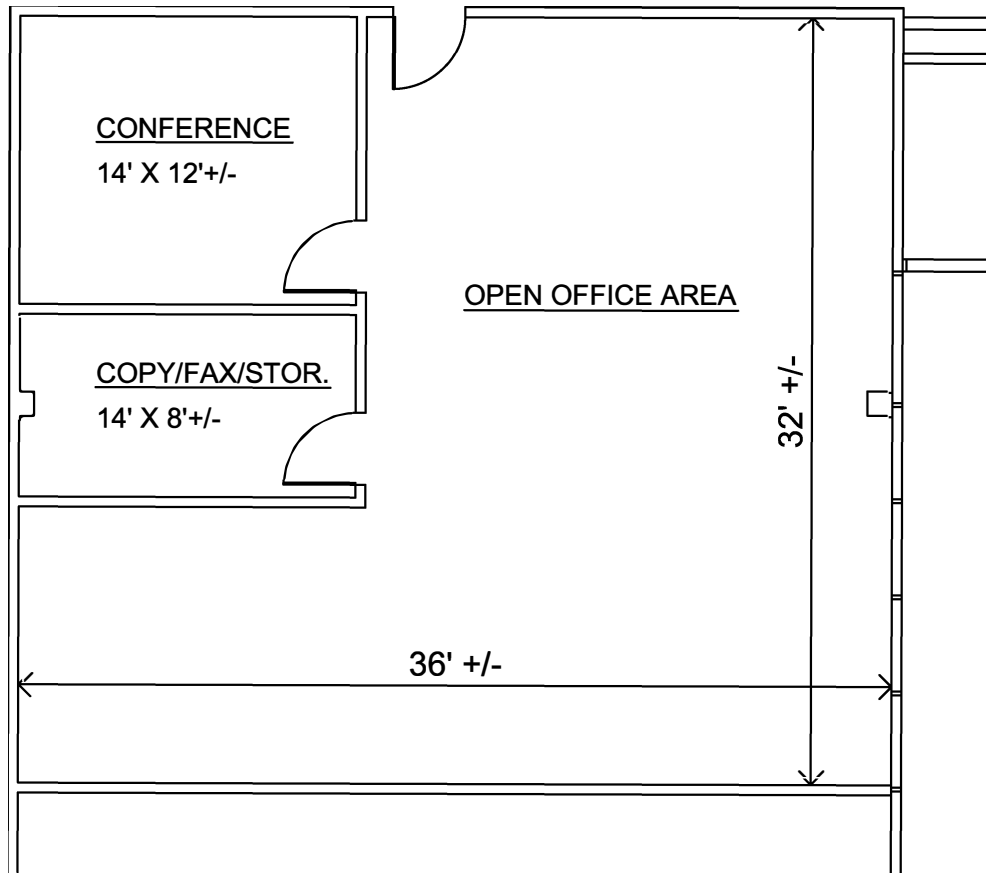

Cascade V - Suite 210

1,359 Sq. Ft. Scale 1/8" = 1' - 0"

Cascade Corporate Center

250 East Wilson Bridge Road - Second Floor
 Worthington, Ohio

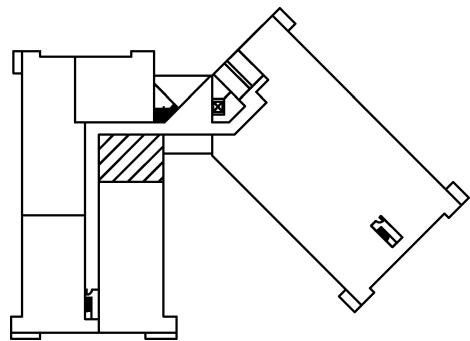

Second Floor Key Plan

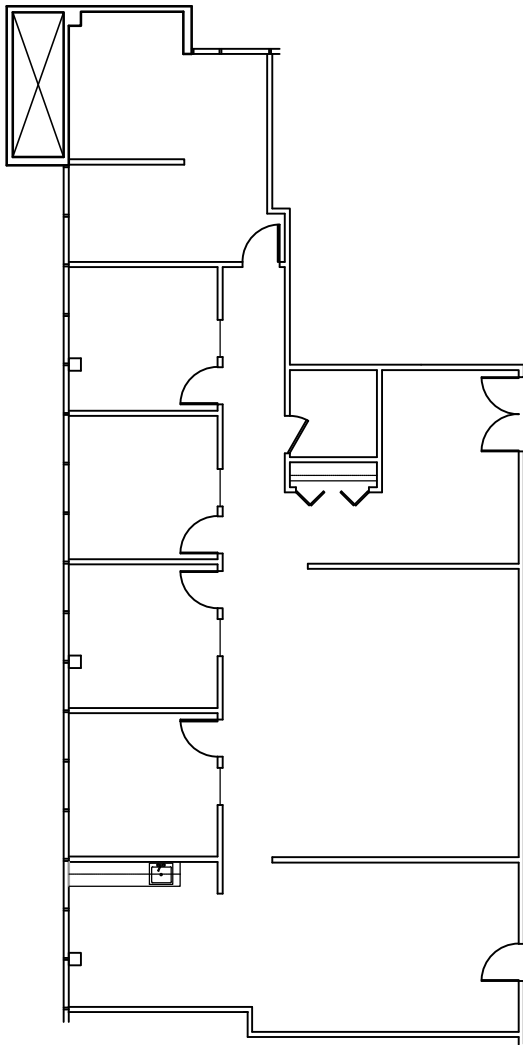

Suite 240
2,741 Sq. Ft.

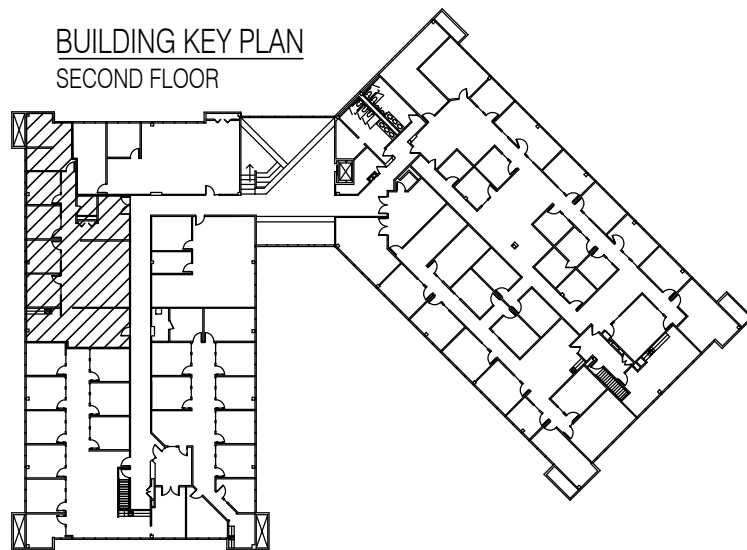

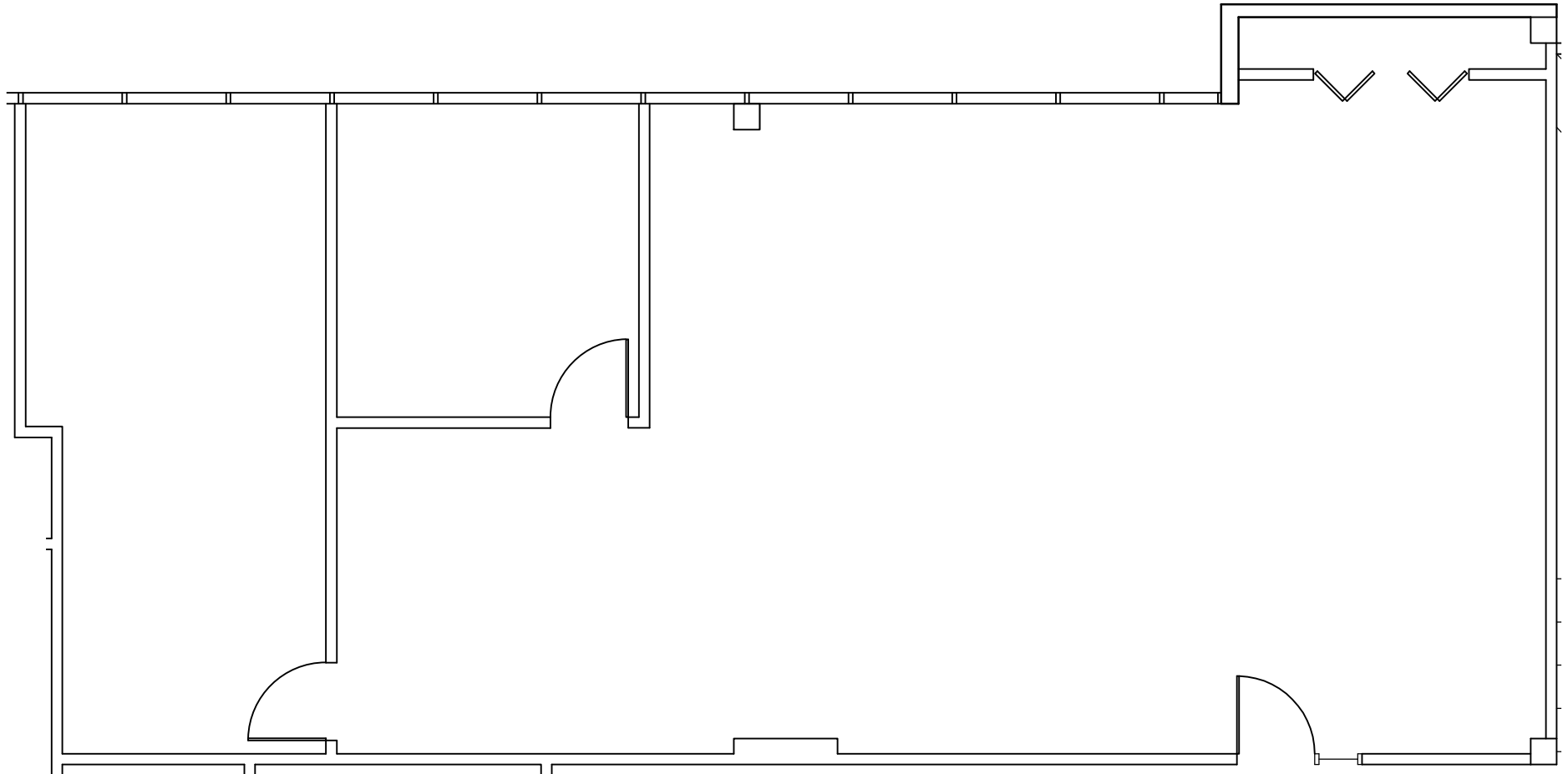

Suite 270

250 E Wilson Bridge Road - Cascade V

N.T.S.

1,760 R.S.F.

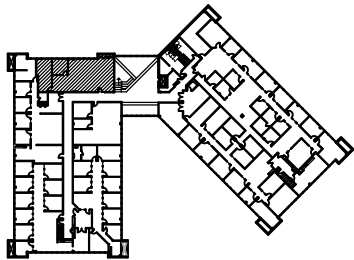

N building key plan

Second Floor

N.T.S.



DARIN RANKER ARCHITECTS
 + INTERIOR DESIGNERS
 5925 Wilcox Place, Suite E Dublin, OH 43016
 Ph. 614-792-1002 Fax 614-792-1001
 admin@darinranker.com