

LANGSTON BLACK

REAL ESTATE, INC.

OFFICE BUILDING FOR LEASE

JUST OFF THE I-85 & HWY 14 INTERCHANGE

304 EAST FRONTAGE ROAD, GREER

1ST FLOOR:
ENTRY AREA
3 OFFICES
OPEN AREA
KITCHEN
2 FULL BATHS

2ND FLOOR:
3 OFFICES
2 OPEN AREAS
KITCHEN
2 FULL BATHS

I-85 EXPOSURE

2,900+- SF

FLOORS CAN BE LEASED SEPARATELY



- TAX MAP 9-07-00-022.02
- ZONED CITY OF GREER CC (COMMERCIAL CORRIDOR)
- LOCATED IN GSP AIRPORT ENVIRONS AREA

- 1,450+- SF PER FLOOR
- NO INTERNAL STAIRCASE
- SEPARATE EXTERIOR FRONT ENTRANCE FOR EACH FLOOR
- 0.58+- ACRE PARCEL

LEASE RATE:

\$4,500/MO FOR ENTIRE BLDG

\$3,000/MO FOR DOWNSTAIRS

\$2,500/MO FOR UPSTAIRS

TENANT PAYS UTILITIES

FOR MORE INFORMATION CONTACT
GLENN YOUNG AT 864-384-4999
gyoung@langston-black.com

LANGSTON BLACK
REAL ESTATE, INC.

P.O. BOX 2167

GREER, S.C. 29652

BUS: 864-848-9070

423



www.langston-black.com

Every effort has been made to ensure the accuracy of the enclosed data, but we assume no responsibility for errors. All conditions and pricing subject to change without notice.
(LANGSTON-BLACK SITE #423)



2ND FLOOR

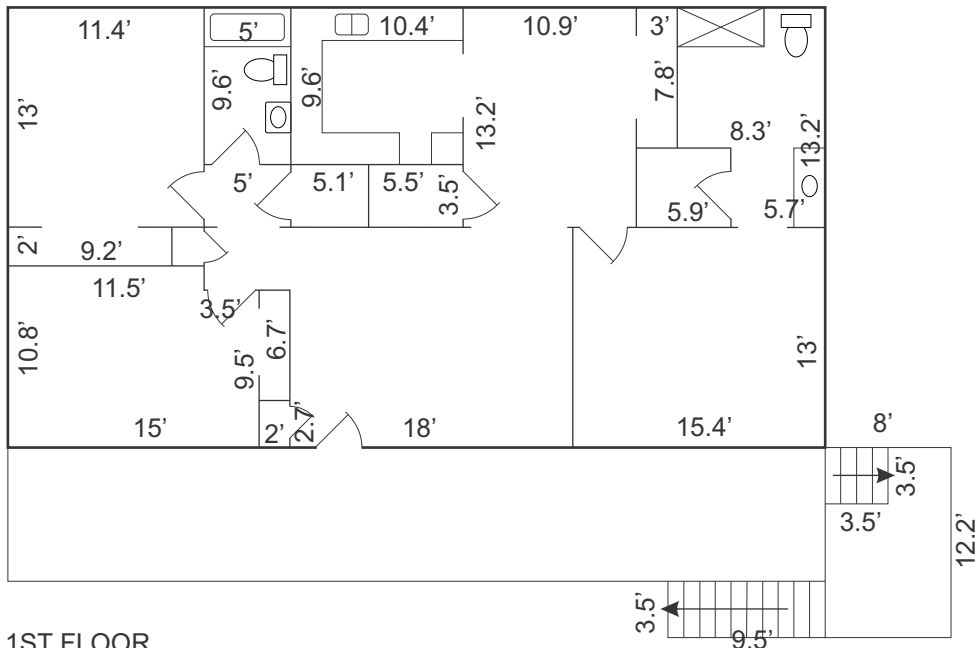

1ST FLOOR

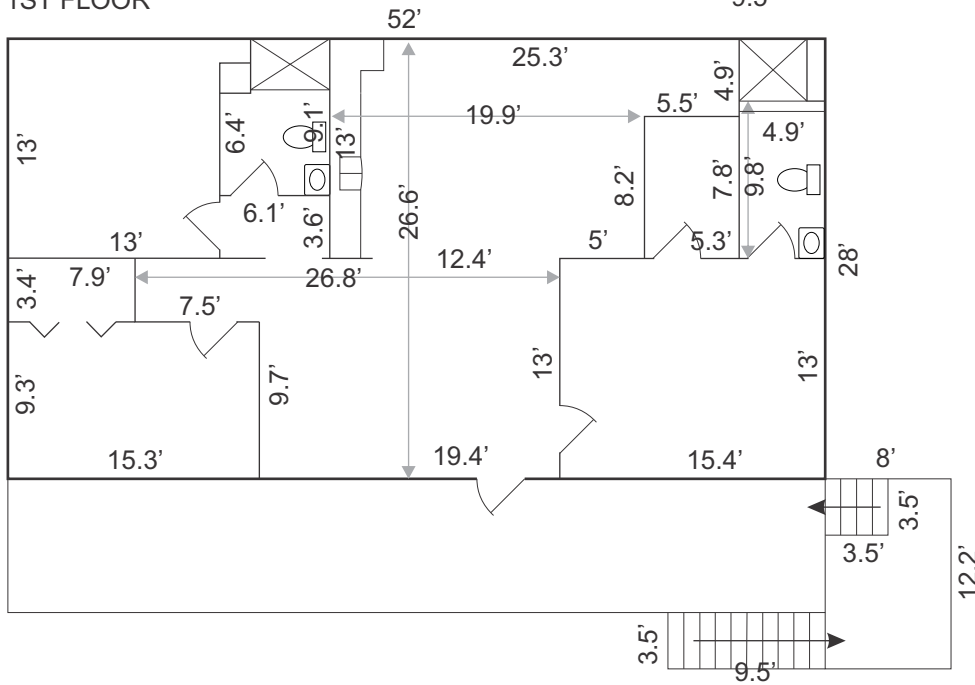



1ST FLOOR





2ND FLOOR





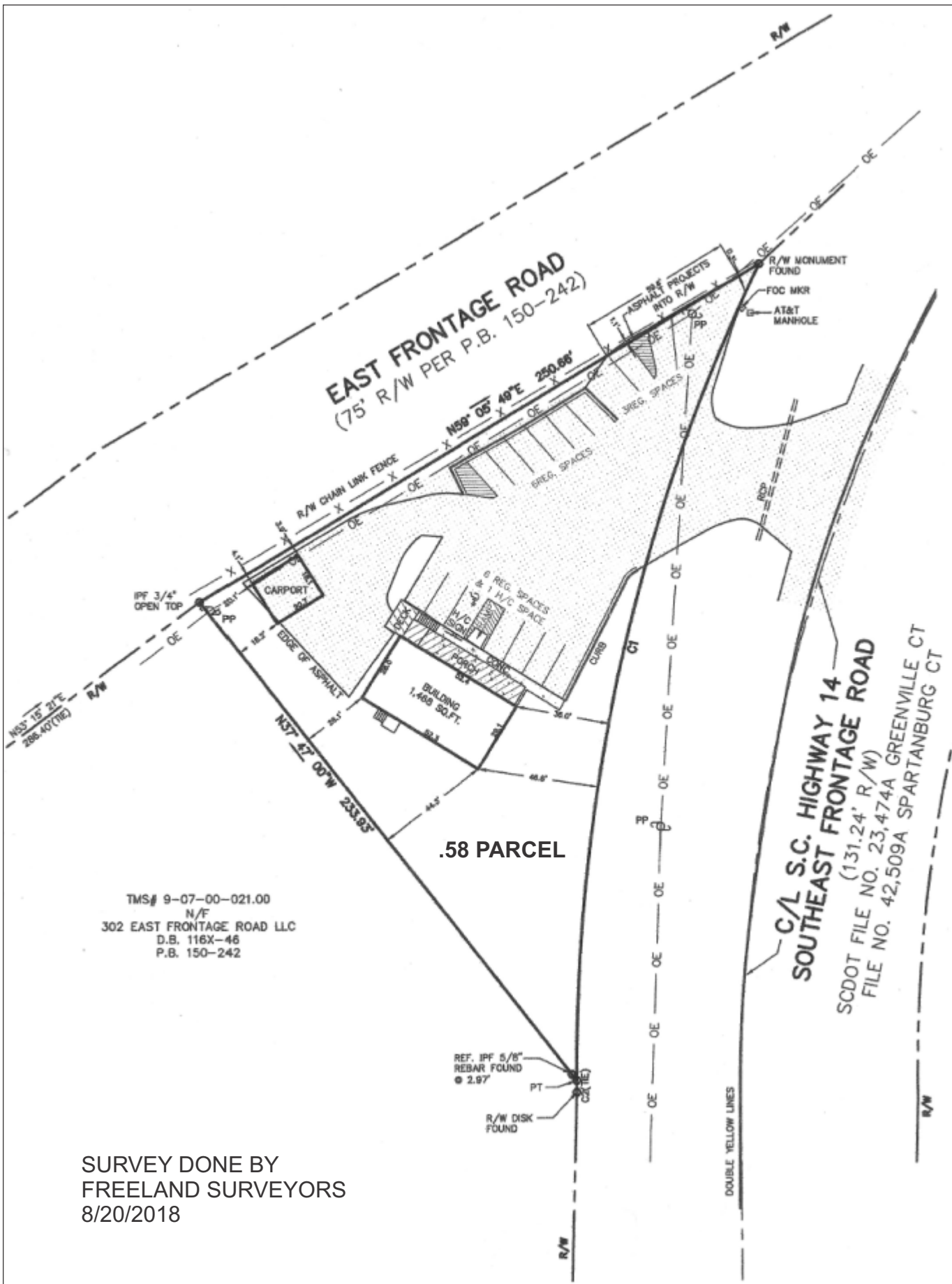

EAST FRONTAGE ROAD
 (75' R/W PER P.B. 150-242)

.58 PARCEL

C/L S.C. HIGHWAY 14
SOUTHEAST FRONTAGE ROAD
 (131.24' R/W)
 SCDOT FILE NO. 23,474A GREENVILLE CT
 FILE NO. 42,509A SPARTANBURG CT

TMS# 9-07-00-021.00
 N/F
 302 EAST FRONTAGE ROAD LLC
 D.B. 116X-46
 P.B. 150-242

SURVEY DONE BY
 FREELAND SURVEYORS
 8/20/2018