

LOCATION

3410 Canfield Rd, Youngstown, OH 44511

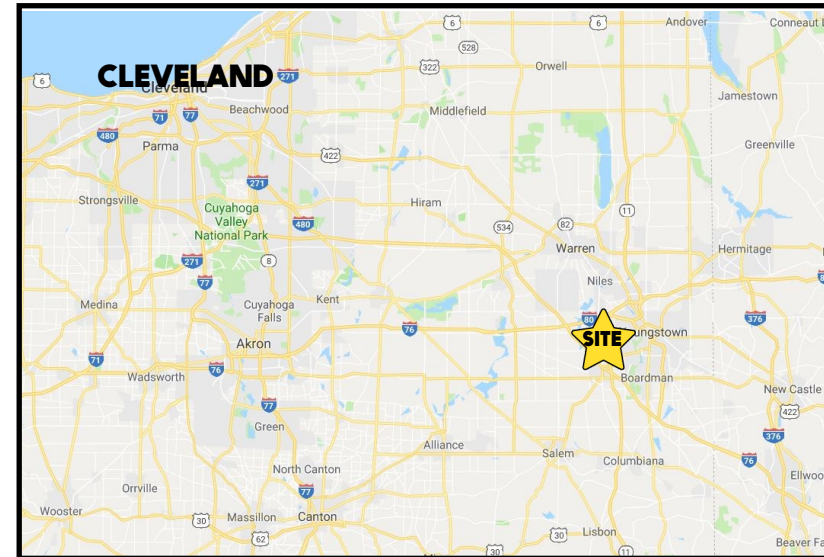

HIGHLIGHTS

- Large retail store w/a drive-in door and fenced side area
- Great street signage with lots of parking
- Access from Canfield Rd and Meridian Rd
- By Rite Aid, Walgreens, Dollar General, DQ, USPS, Dunkin', Farmers, Sparkle, and more

TRAFFIC

Meridian Rd = 11,616 VPD
Canfield Rd = 8,866 VPD

[3D Tour](#)

CONTACT

BILL KUTLICK

330.565.5701

bkutlick@platzrealtygroup.com

Office: 330.757.4889 | Fax: 330.294.5622 | 3830 Starr Centre Dr, Suite 2, Canfield, OH 44406

www.PLATZREALTYGROUP.com



Office: 330.757.4889 | Fax: 330.294.5622 | 3830 Starr Centre Dr, Suite 2, Canfield, OH 44406

www.PLATZREALTYGROUP.com

The information presented was obtained from sources believed to be true and reliable. The Platz Realty Group makes no warranties or guarantees to the accuracy of the information.



Office: 330.757.4889 | Fax: 330.294.5622 | 3830 Starr Centre Dr, Suite 2, Canfield, OH 44406

www.PLATZREALTYGROUP.com

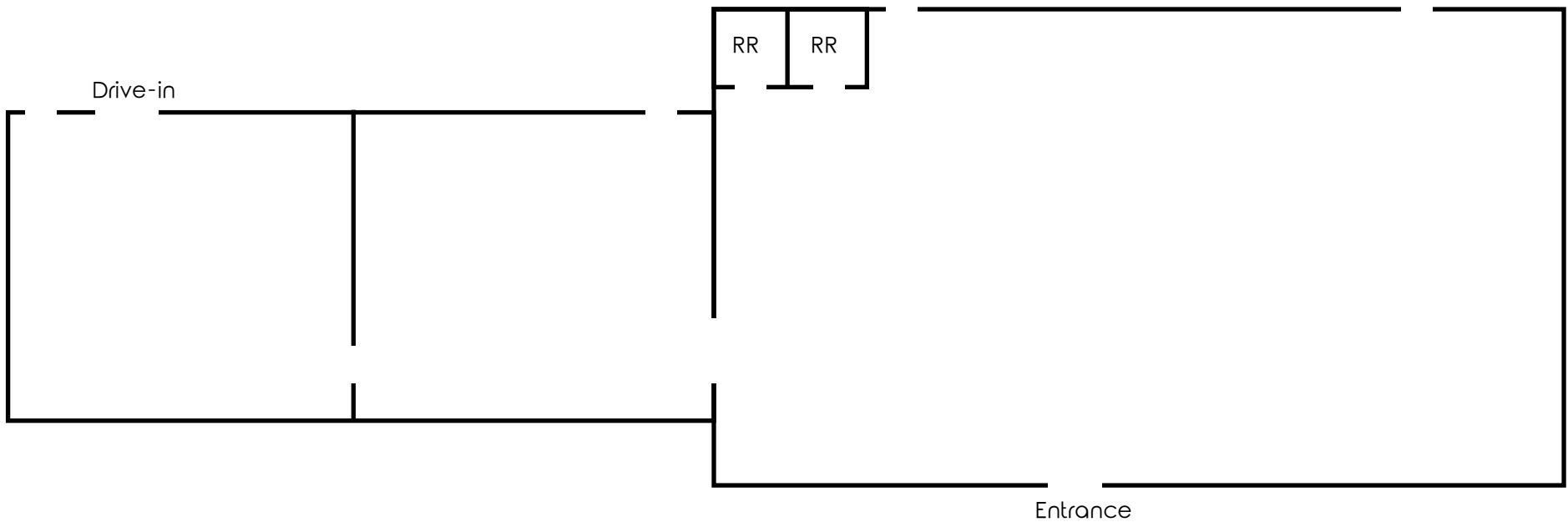

Office: 330.757.4889 | Fax: 330.294.5622 | 3830 Starr Centre Dr, Suite 2, Canfield, OH 44406

www.PLATZREALTYGROUP.com

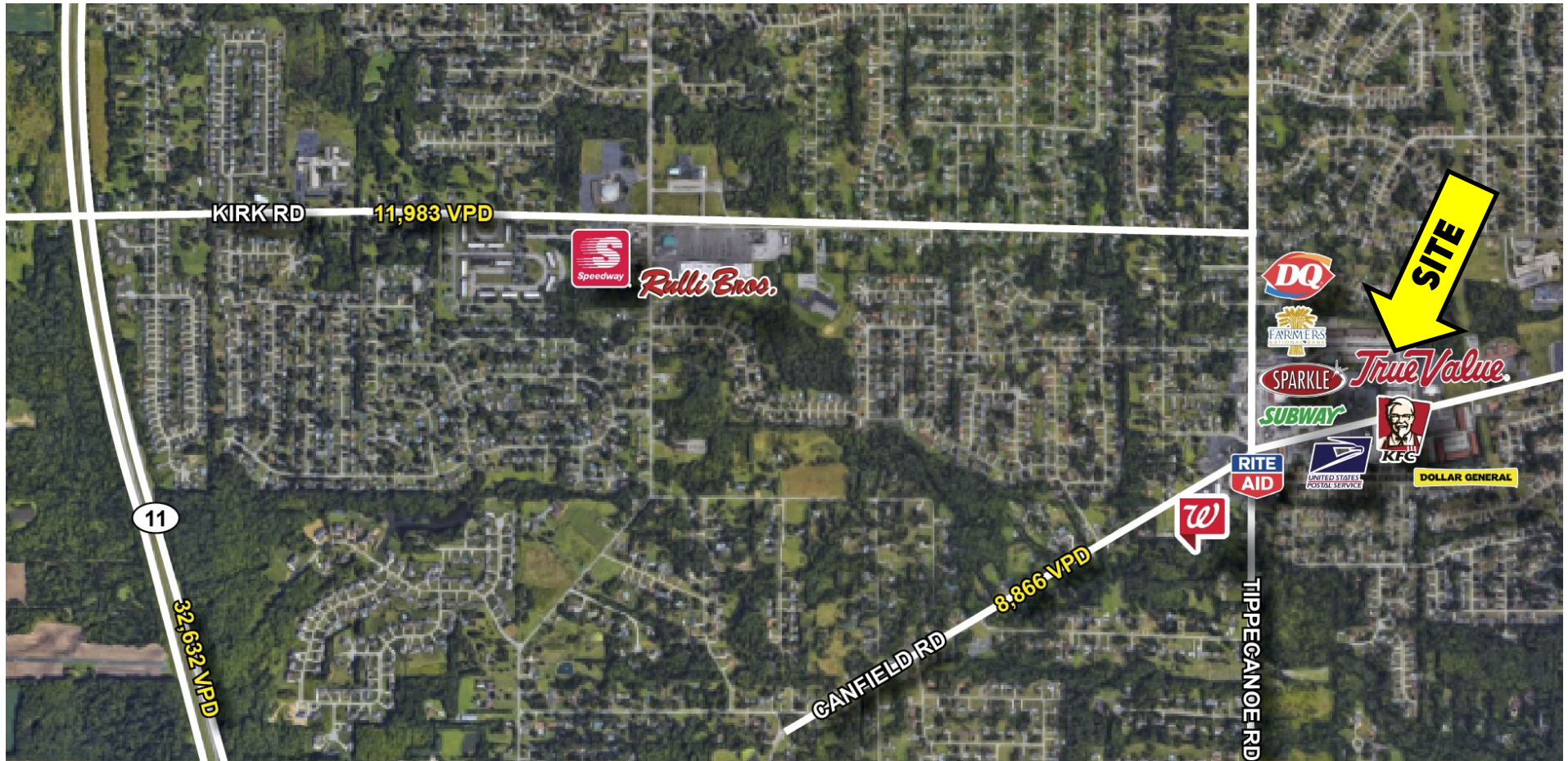

Office: 330.757.4889 | Fax: 330.294.5622 | 3830 Starr Centre Dr, Suite 2, Canfield, OH 44406

www.PLATZREALTYGROUP.com

The information presented was obtained from sources believed to be true and reliable. The Platz Realty Group makes no warranties or guarantees to the accuracy of the information.

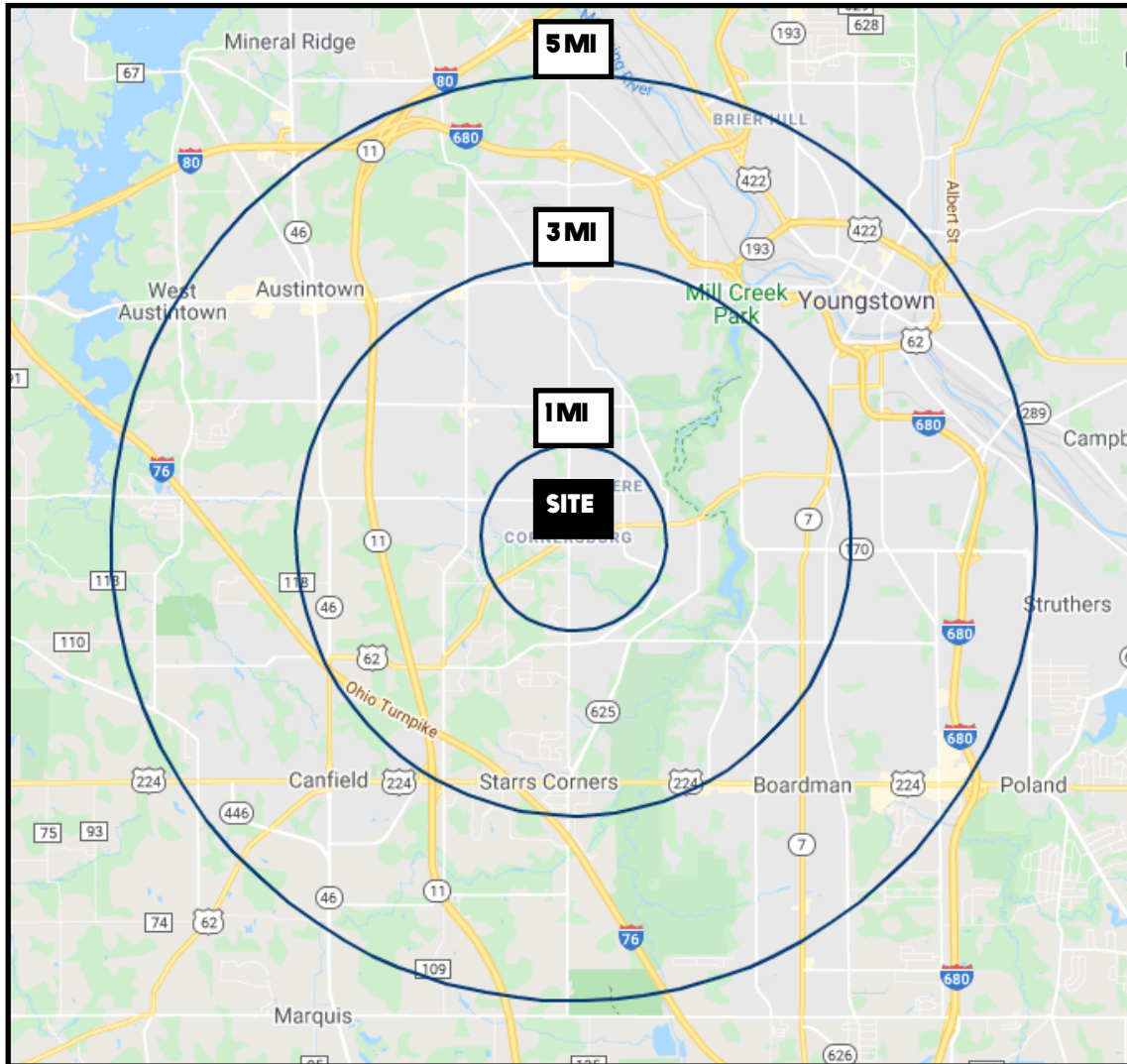

DEMOGRAPHICS	1 MI	3 MI	5 MI
POPULATION	7,601	61,544	130,362
HOUSEHOLDS	3,413	26,860	55,221
MEDIAN AGE	48	43	42
AVERAGE HH INCOME	\$67,314	\$63,303	\$63,222

SITE INFORMATION

LOCATION	Youngstown City Mahoning County
PROPERTY TYPE	Retail / Office
ZONING	MU-C Community
SIZE	6,484 SF LL may subdivide space
UTILITIES	Separately metered
SIGNAGE	Building and pylon
RENT	\$8-10.00/SF Gross

Office: 330.757.4889 | Fax: 330.294.5622 | 3830 Starr Centre Dr, Suite 2, Canfield, OH 44406