

3617 State St

SANTA BARBARA, CA



For Lease | Retail Suite in Ontare Plaza | **1,500 SF**

Experience. Integrity. Trust.
Since 1993

Dylan Ward
805.898.4392
dylan@hayescommercial.com
lic. 01472452



PROPERTY SUMMARY

Located along one of Santa Barbara's most established and high-traffic retail corridors, this Upper State Street / San Roque retail suite at Ontare Plaza offers exceptional visibility and strong daily consumer traffic. Join a dynamic tenant mix including Baskin Robbins, Jeannine's Bakery, Rudy's Mexican, SALT Salon, Sleep Shoppe, and Tri-County Blinds. Centrally situated in the heart of the San Roque neighborhood, the property benefits from proximity to Gelson's, Whole Foods, La Cumbre Plaza, and the Estancia condominium complex, driving consistent consumer activity. Currently occupied by T-Mobile, the suite offers excellent visibility and flexibility to accommodate a wide range of retail uses.

Size	1,500 SF
Rate	\$3.50 NNN (.91)
Utilities	Tenant to pay, trash included in NNNs
Term	3-5 years
Availability	7/1/26
Parking	1 reserved, plus common lot
HVAC	Yes
Restrooms	One, private
To Show	Call listing agent



Experience. Integrity. Trust.
Since 1993

Dylan Ward
805.898.4392
dylan@hayescommercial.com
lic. 01472452



FLOOR PLAN

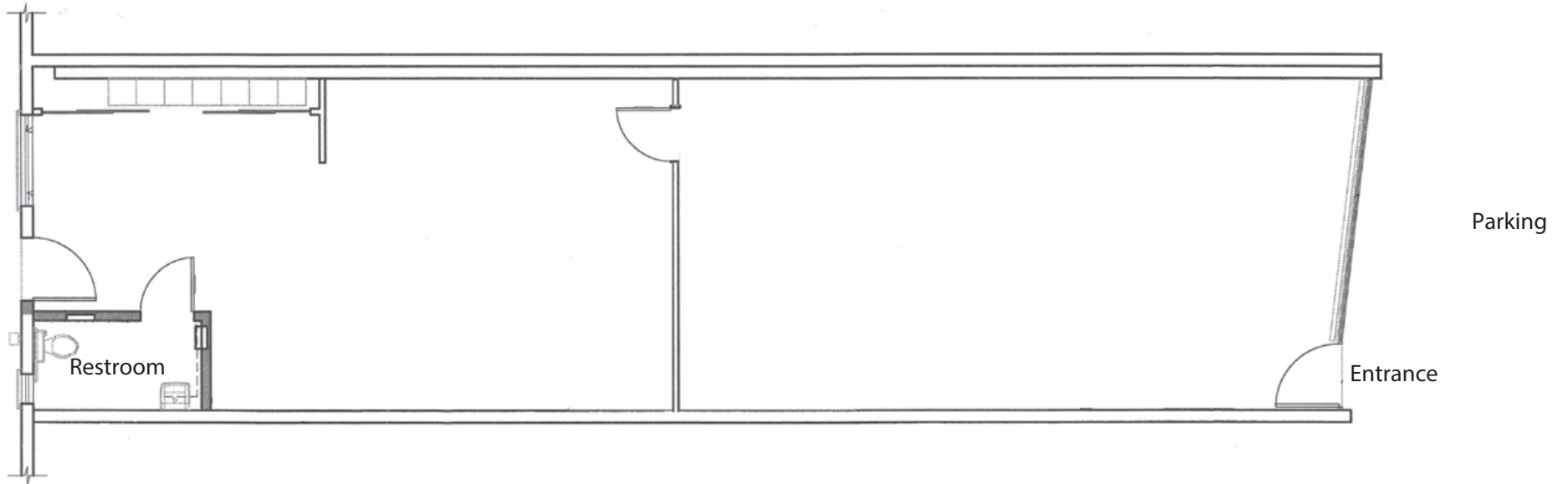

Experience. Integrity. Trust.
Since 1993

Dylan Ward
805.898.4392
dylan@hayescommercial.com
lic. 01472452



SITE PLAN

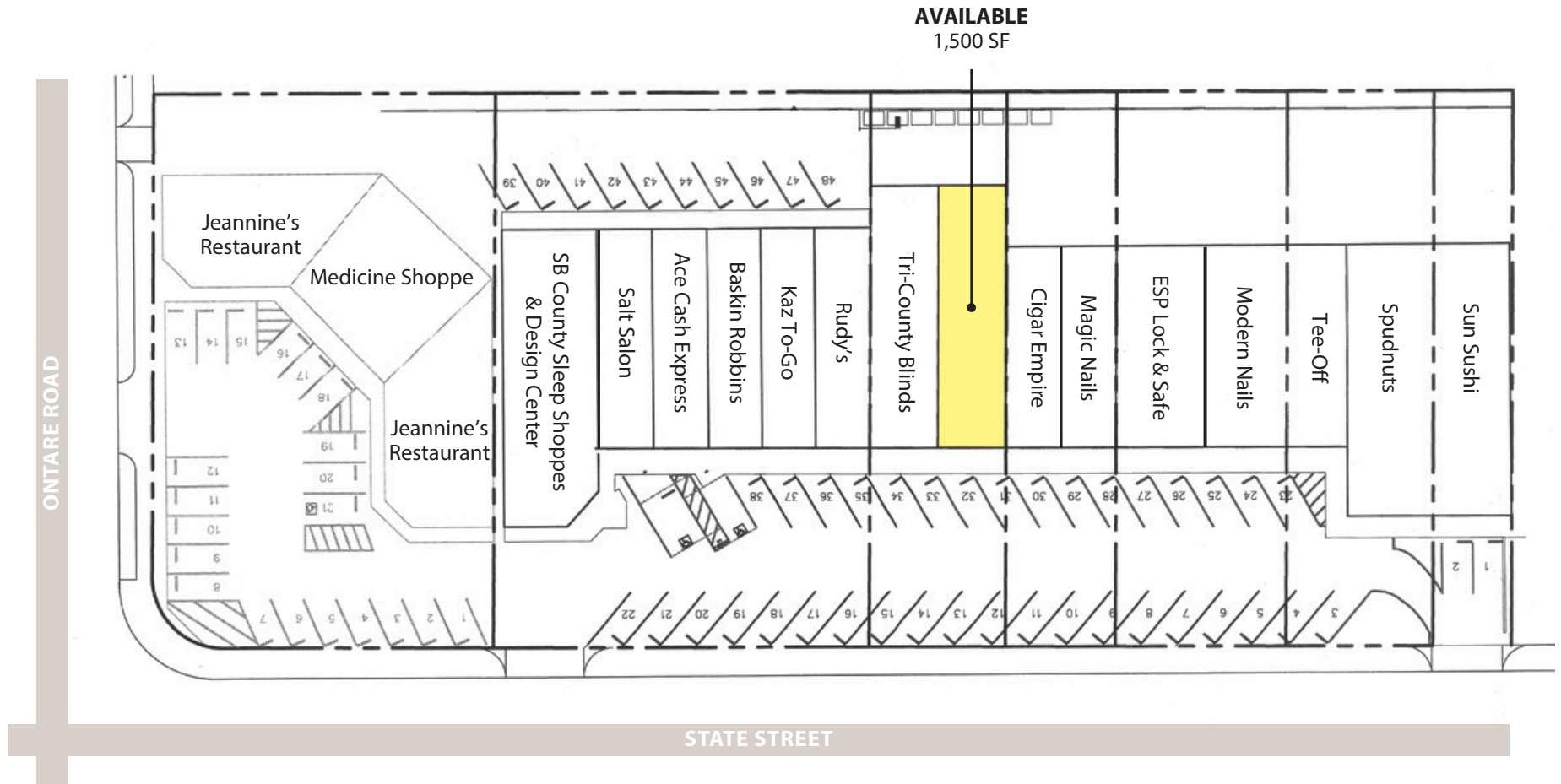

Experience. Integrity. Trust.
Since 1993

Dylan Ward
805.898.4392
dylan@hayescommercial.com
lic. 01472452





La Cumbre Plaza

Macy's	Lure Fish House
Starbucks	Pottery Barn
Wing Stop	Bristol Farms
Chipotle	Williams-Sonoma

Five Points Shopping Center

Smart & Final
Starbucks
CVS
Ross
T-Mobile
Luna Grill
Peet's Coffee
Petco

SITE

Loreto Plaza

Gelson's	Harry's Plaza Cafe
Chase Bank	Chaucer's Books
Cox store	Renaud's Patisserie
Singer's Big & Tall	Jersey Mike's

- 1 Santa Barbara Golf Club
- 2 Whole Foods
- 3 Estancia development, 72 residential units and three commercial buildings, completed 2019
- 4 The Marc development, 89 1-3/BD residential units, completed February 2018
- 5 Grace Village development, 58 1BD/1BA residential units, completed March 2018
- 6 Target

Experience. Integrity. Trust.
Since 1993

Dylan Ward
805.898.4392
dylan@hayescommercial.com
lic. 01472452

