

# Ground Floor

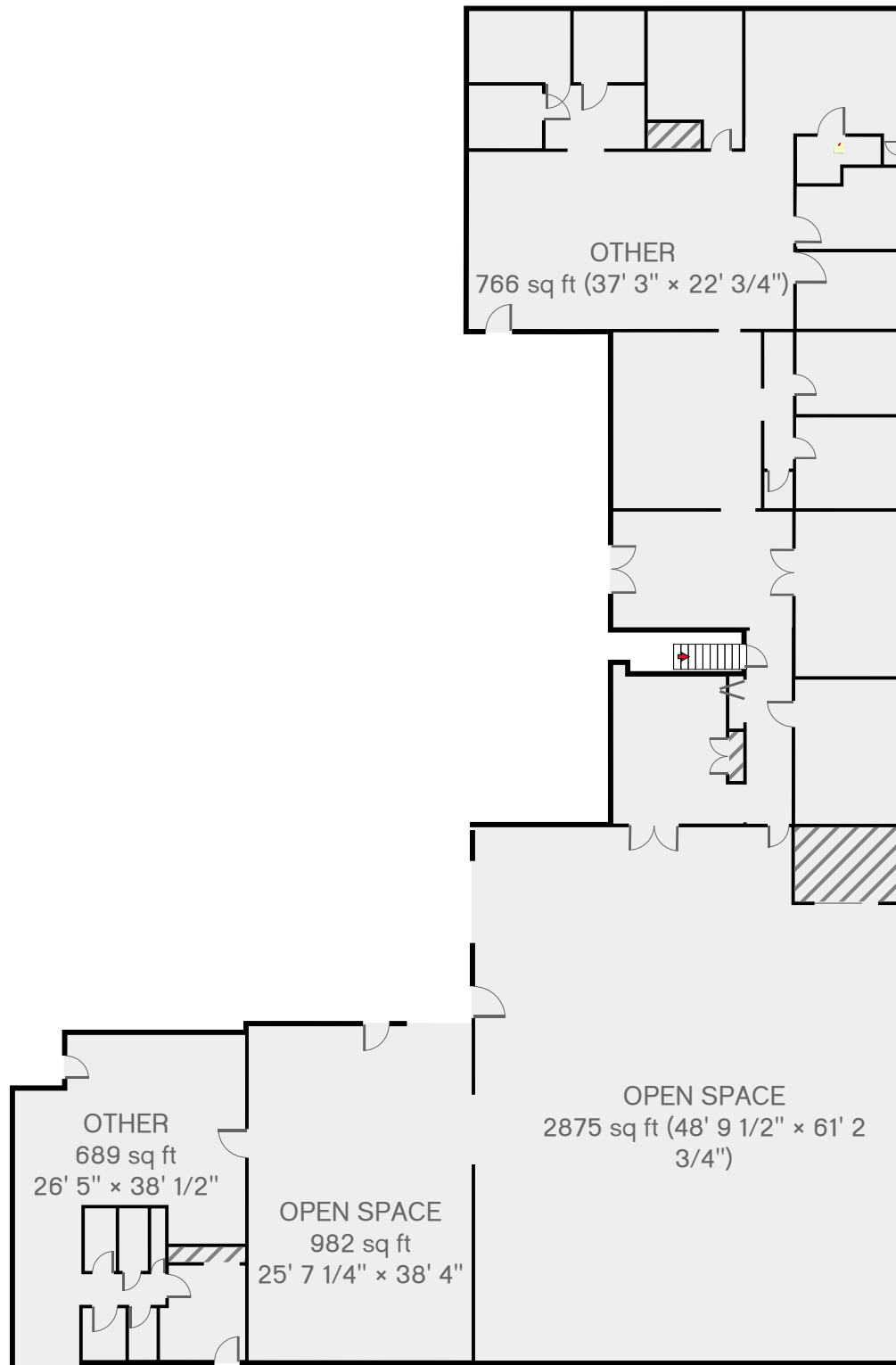

## 206 Macopin Rd

Bloomington, NJ, United States 07403

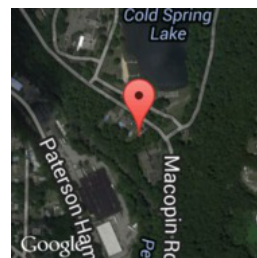

18302 sq ft

2 Floors

36 Rooms

7 Offices

1 conf. room

THIS FLOORPLAN IS PROVIDED WITHOUT WARRANTY OF ANY KIND. SENSOPIA DISCLAIMS ANY WARRANTY INCLUDING, WITHOUT LIMITATION, SATISFACTORY QUALITY OR ACCURACY OF DIMENSIONS.

# Lab

Width: 14' 11"  
Area: 229 sq ft

Length: 18' 3 3/4"  
Perimeter: 66' 4"

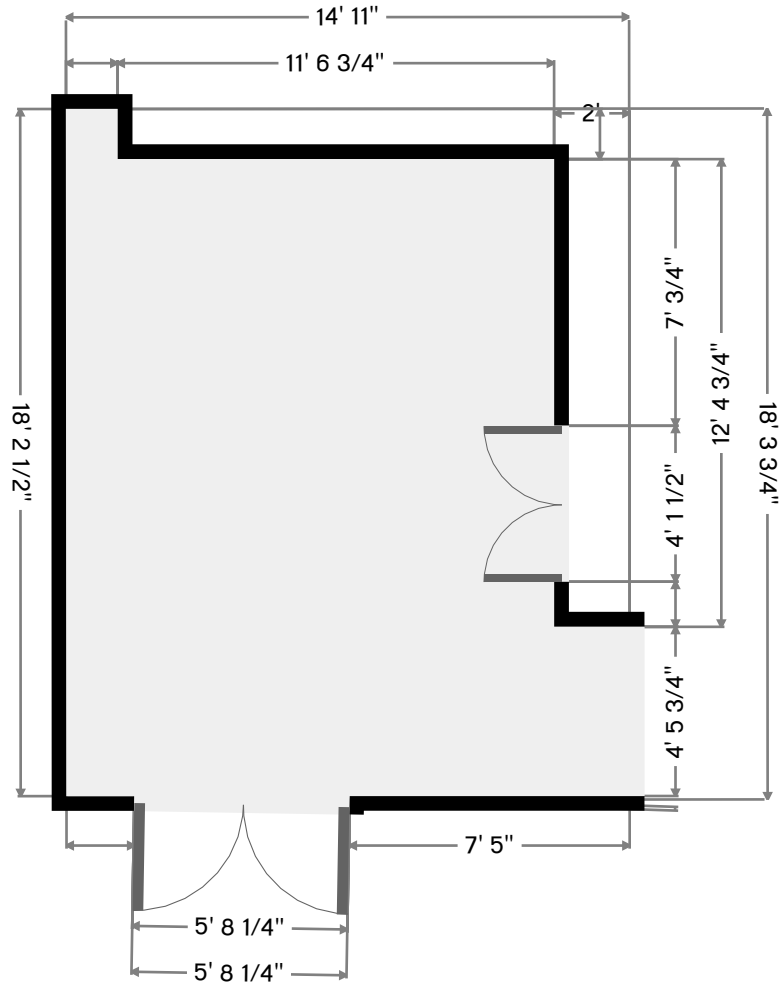
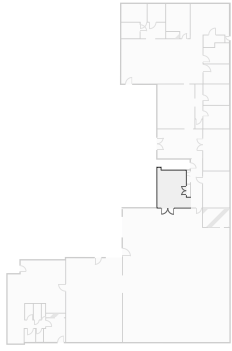

# Other

Width: 1' 7 1/4"  
Area: 11 sq ft

Length: 7' 2"  
Perimeter: 17' 6 1/4"

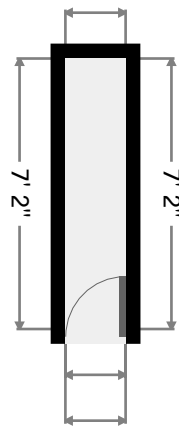
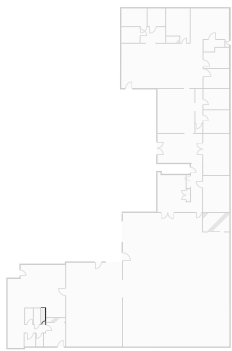

THIS FLOORPLAN IS PROVIDED WITHOUT WARRANTY OF ANY KIND. SENSOPIA DISCLAIMS ANY WARRANTY INCLUDING, WITHOUT LIMITATION, SATISFACTORY QUALITY OR ACCURACY OF DIMENSIONS.



206 Macopin Rd

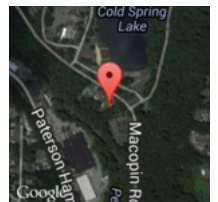

# Other

Width: 3' 3 1/4"  
Area: 24 sq ft

Length: 7' 2"  
Perimeter: 20' 10 3/4"

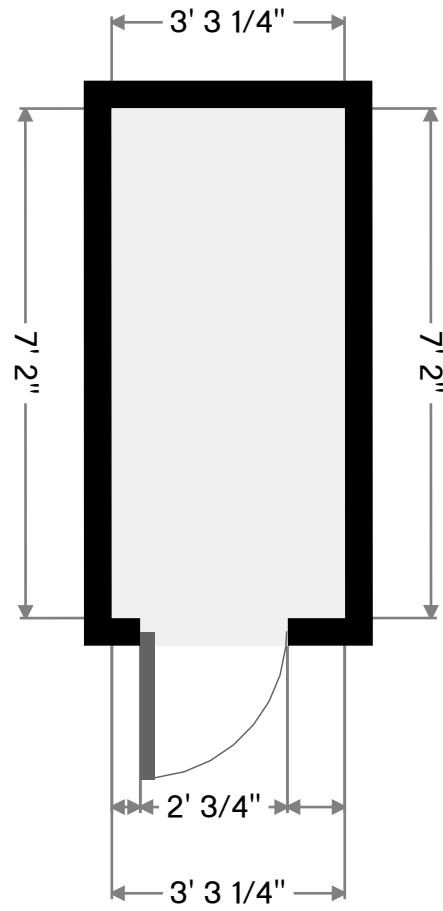
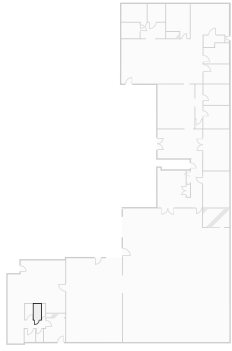

# Other

Width: 3' 6 1/2"  
Area: 26 sq ft

Length: 7' 2 1/4"  
Perimeter: 21' 5 3/4"

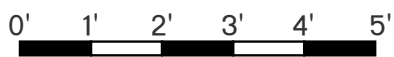
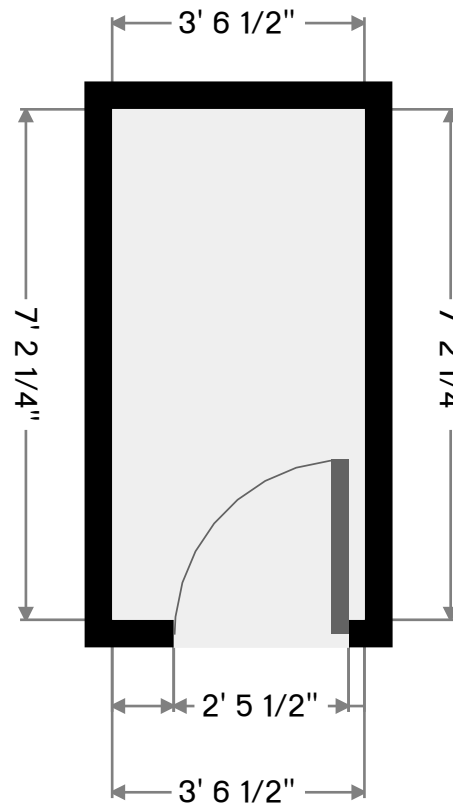
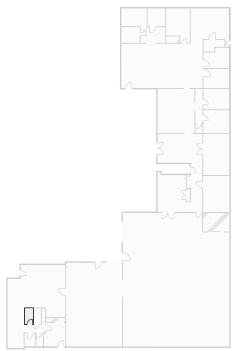

THIS FLOORPLAN IS PROVIDED WITHOUT WARRANTY OF ANY KIND. SENSOPIA DISCLAIMS ANY WARRANTY INCLUDING, WITHOUT LIMITATION, SATISFACTORY QUALITY OR ACCURACY OF DIMENSIONS.



206 Macopin Rd

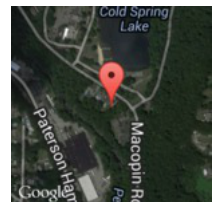

# Private Office

Width: 9' 9 1/4"  
Area: 101 sq ft

Length: 10' 10"  
Perimeter: 41' 2 1/4"

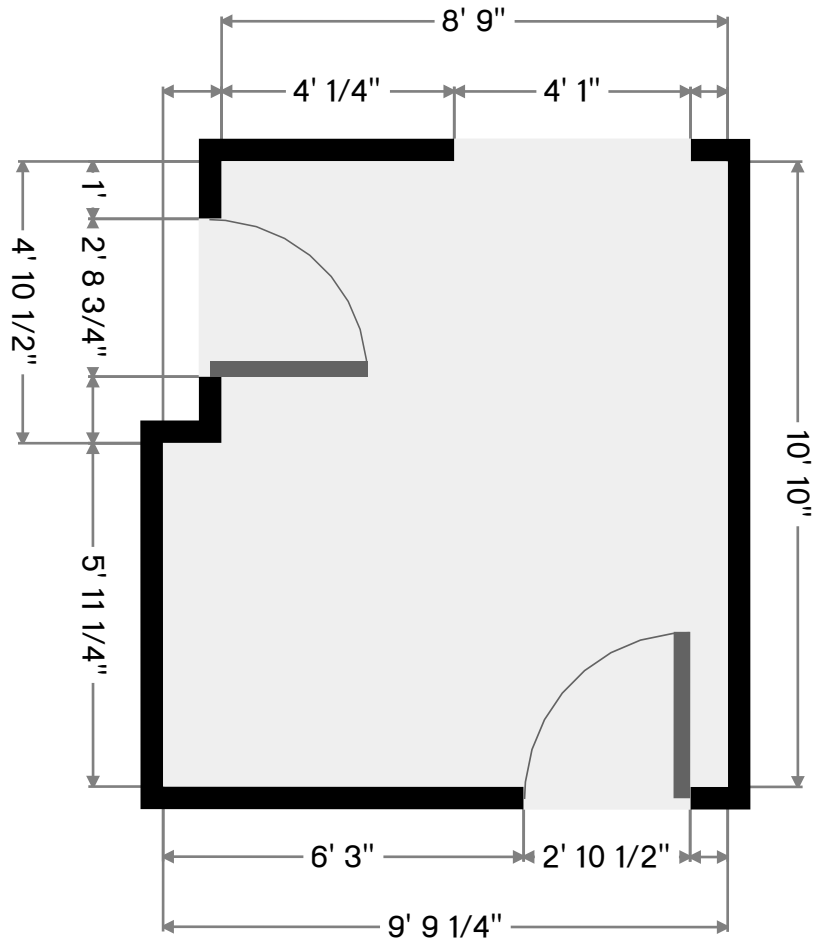
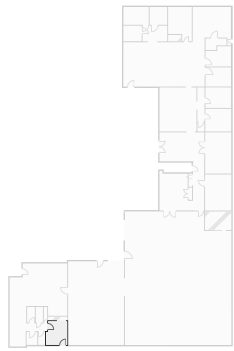

# Other

Width: 3' 2"  
Area: 19 sq ft

Length: 5' 11 1/4"  
Perimeter: 18' 2 1/4"

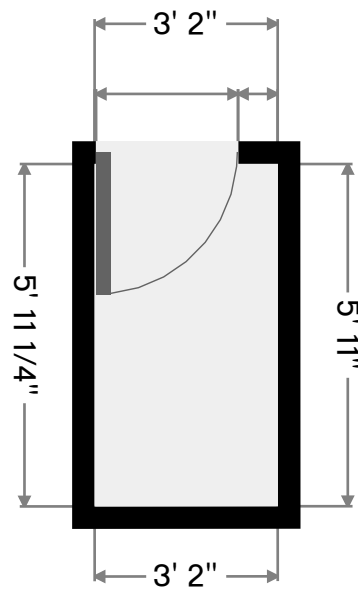
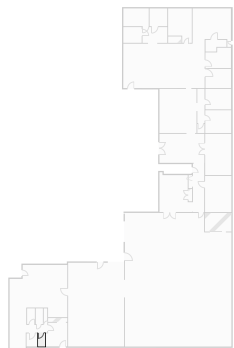

THIS FLOORPLAN IS PROVIDED WITHOUT WARRANTY OF ANY KIND. SENSOPIA DISCLAIMS ANY WARRANTY INCLUDING, WITHOUT LIMITATION, SATISFACTORY QUALITY OR ACCURACY OF DIMENSIONS.



206 Macopin Rd

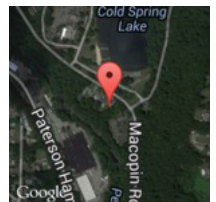

# Other

Width: 4' 11"  
Area: 29 sq ft

Length: 5' 11 1/2"  
Perimeter: 21' 8 3/4"

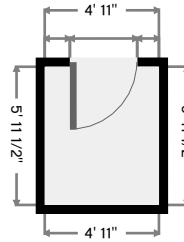
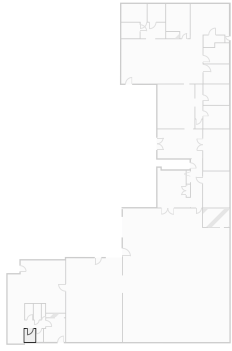

# Other

Width: 26' 5"  
Area: 689 sq ft

Length: 38' 1/2"  
Perimeter: 157' 3/4"

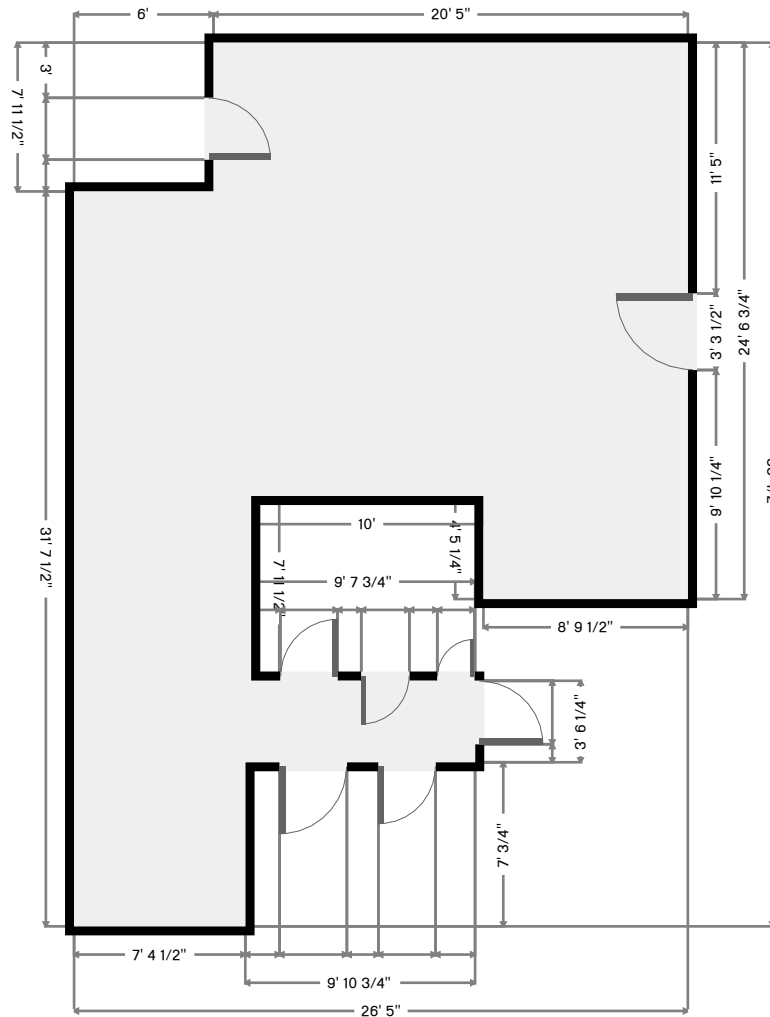
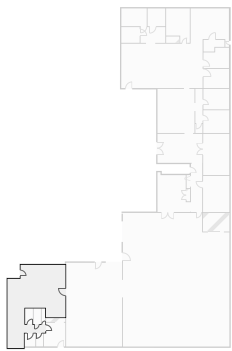

THIS FLOORPLAN IS PROVIDED WITHOUT WARRANTY OF ANY KIND. SENSOPIA DISCLAIMS ANY WARRANTY INCLUDING, WITHOUT LIMITATION, SATISFACTORY QUALITY OR ACCURACY OF DIMENSIONS.



206 Macopin Rd

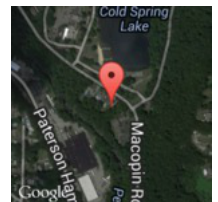

# Open Space

Width: 25' 7 1/4"  
Area: 982 sq ft

Length: 38' 4"  
Perimeter: 127' 10 3/4"

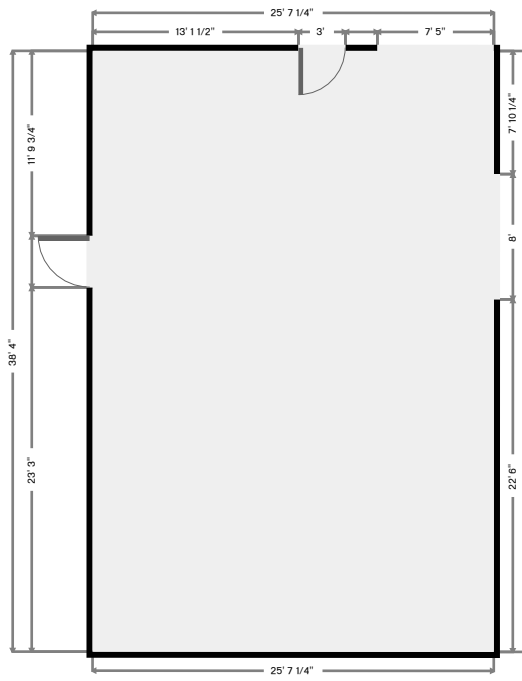
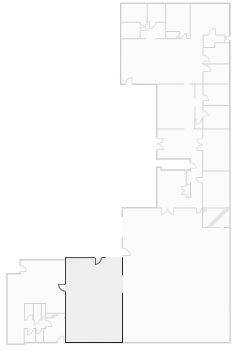

# Open Space

Width: 48' 9 1/2"  
Area: 3875 sq ft

Length: 61' 2 3/4"  
Perimeter: 220' 1/4"

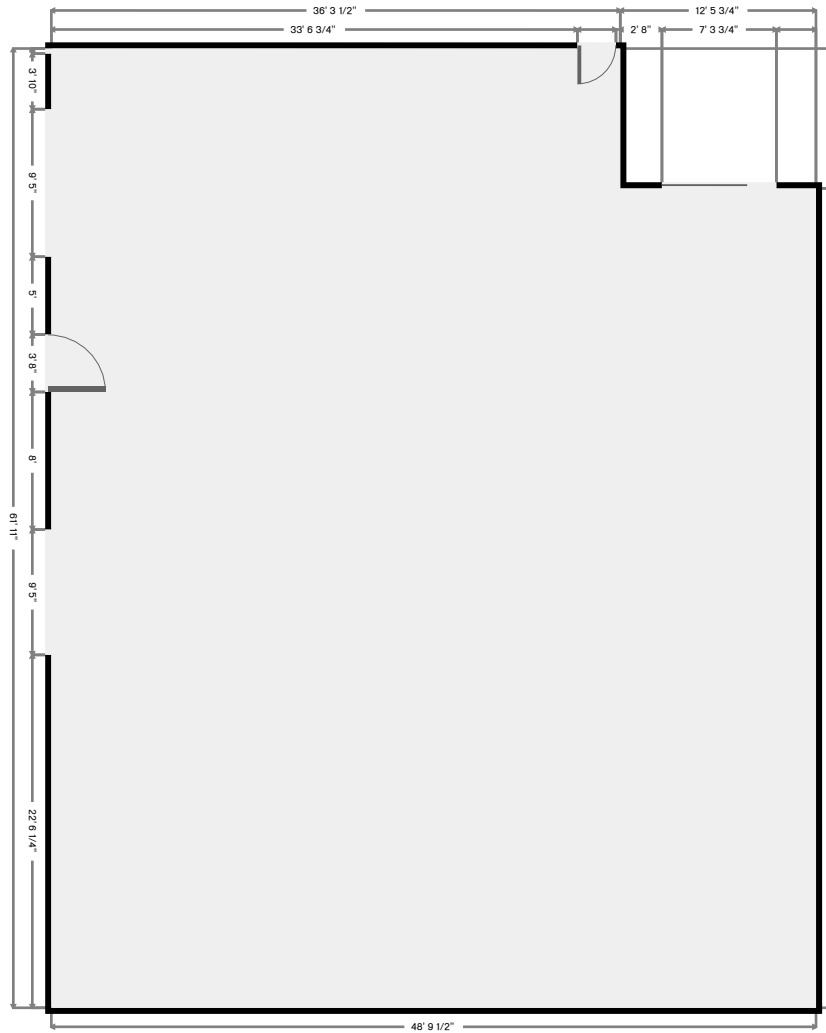
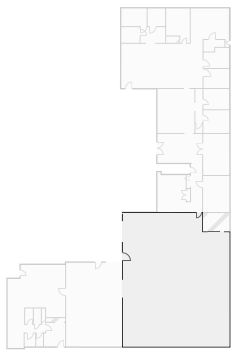

THIS FLOORPLAN IS PROVIDED WITHOUT WARRANTY OF ANY KIND. SENSOPIA DISCLAIMS ANY WARRANTY INCLUDING, WITHOUT LIMITATION, SATISFACTORY QUALITY OR ACCURACY OF DIMENSIONS.



206 Macopin Rd

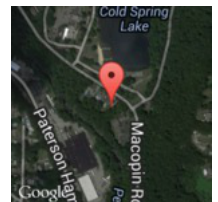

# Other

Width: 3' 2 3/4"  
Area: 13 sq ft

Length: 4' 2"  
Perimeter: 14' 9 1/2"

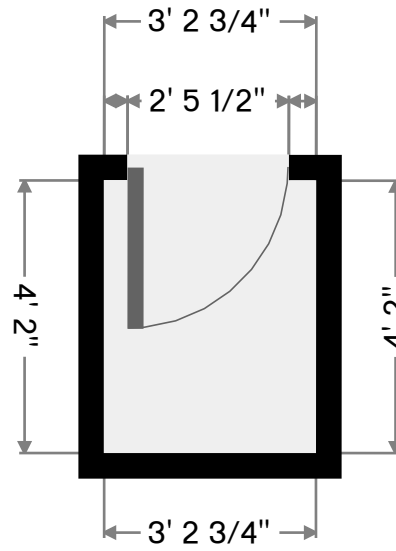
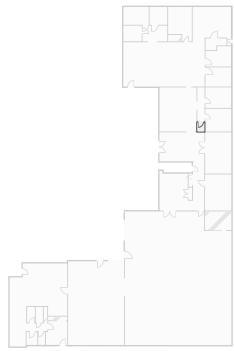

# Toilet

Width: 10' 5"  
Area: 123 sq ft

Length: 11' 10 1/4"  
Perimeter: 44' 6 1/2"

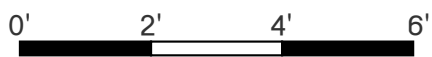
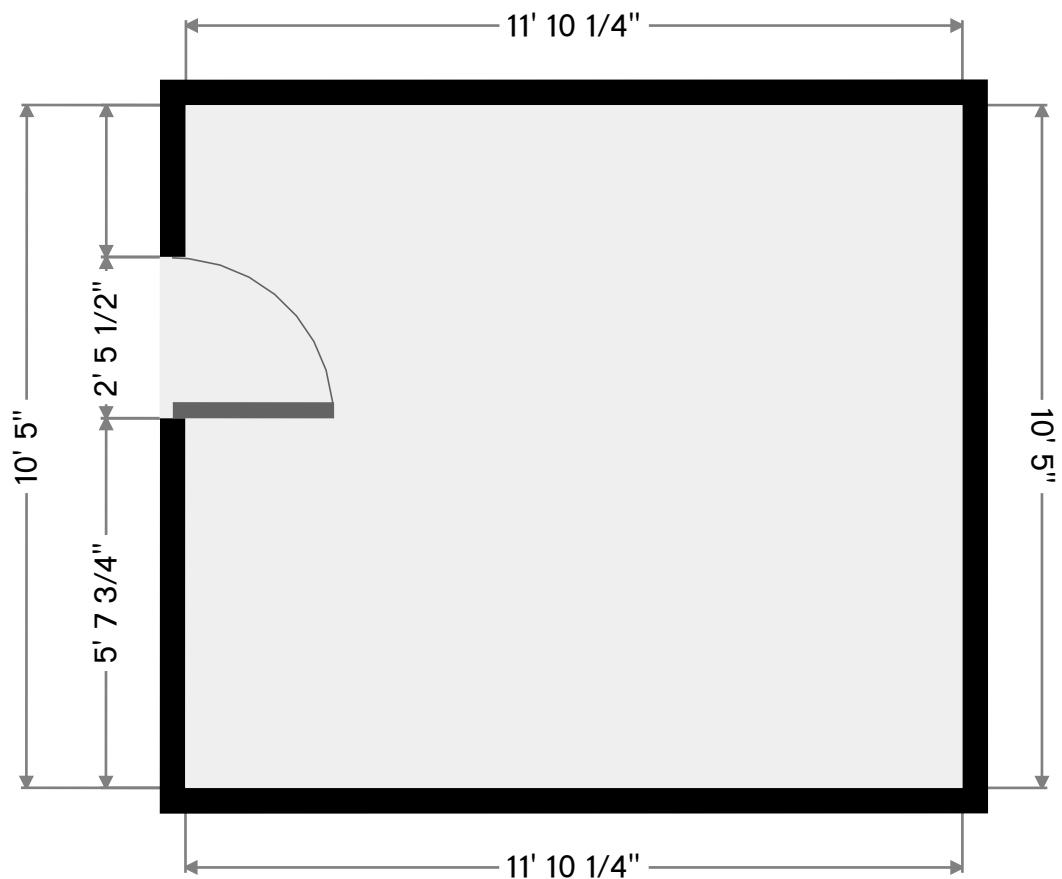
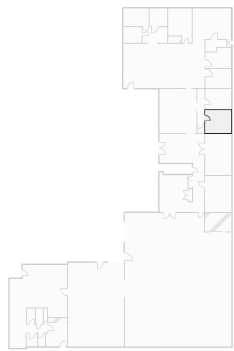

THIS FLOORPLAN IS PROVIDED WITHOUT WARRANTY OF ANY KIND. SENSOPIA DISCLAIMS ANY WARRANTY INCLUDING, WITHOUT LIMITATION, SATISFACTORY QUALITY OR ACCURACY OF DIMENSIONS.



206 Macopin Rd

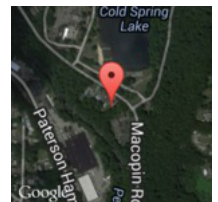

# Toilet

Width: 9' 4 3/4"  
Area: 111 sq ft

Length: 11' 9 1/4"  
Perimeter: 42' 4"

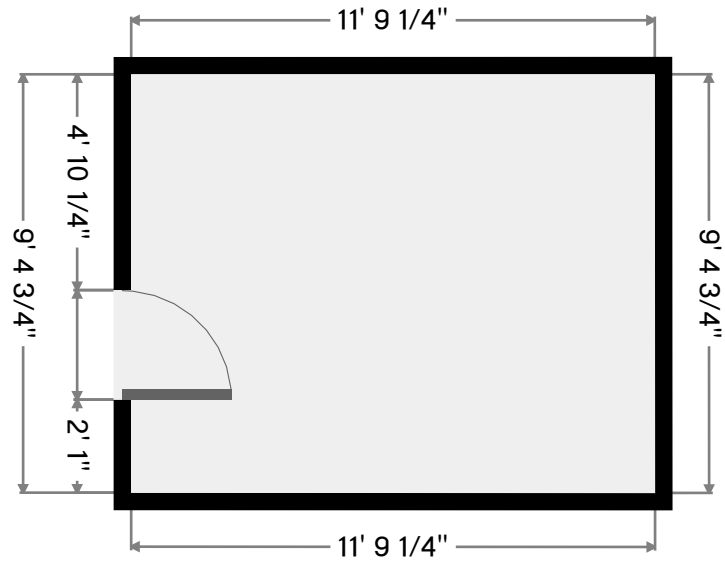
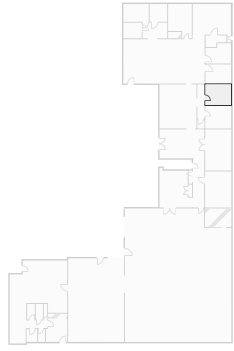

# Other

Width: 3' 3 1/4"  
Area: 51 sq ft

Length: 15' 7 3/4"  
Perimeter: 37' 10 1/2"

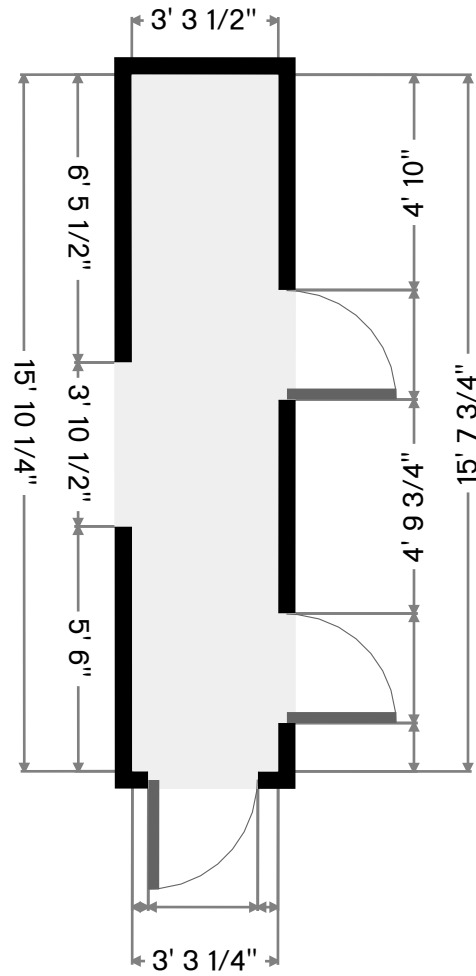
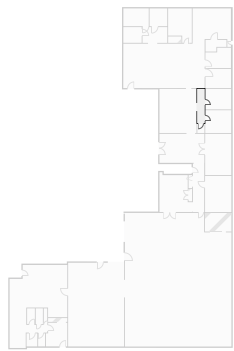

THIS FLOORPLAN IS PROVIDED WITHOUT WARRANTY OF ANY KIND. SENSOPIA DISCLAIMS ANY WARRANTY INCLUDING, WITHOUT LIMITATION, SATISFACTORY QUALITY OR ACCURACY OF DIMENSIONS.



206 Macopin Rd

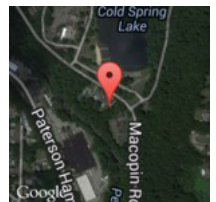



# Server Room

Width: 12' 1/2"  
Area: 199 sq ft

Length: 16' 6 1/2"  
Perimeter: 57' 1 3/4"

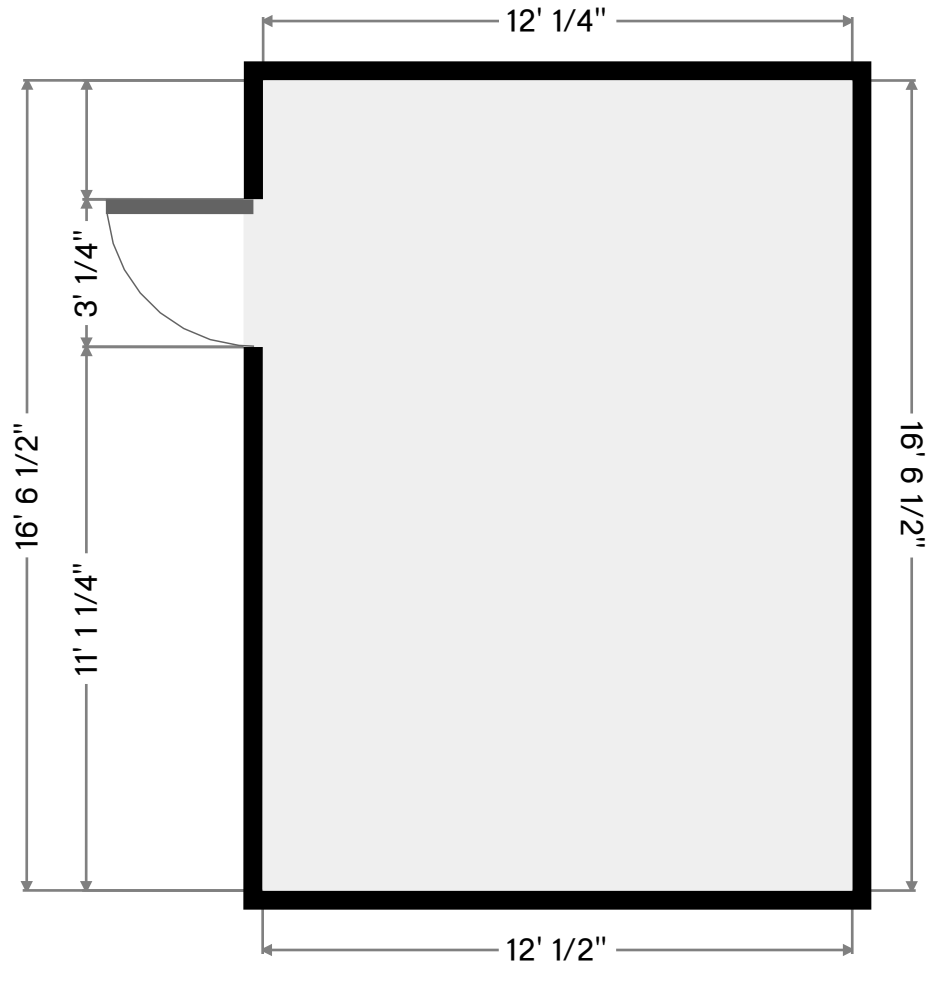
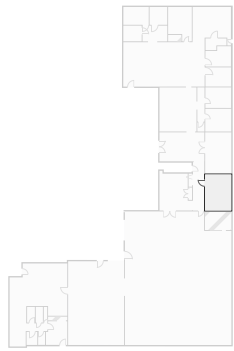

Room  
Network Location

THIS FLOORPLAN IS PROVIDED WITHOUT WARRANTY OF ANY KIND. SENSOPIA DISCLAIMS ANY WARRANTY INCLUDING, WITHOUT LIMITATION, SATISFACTORY QUALITY OR ACCURACY OF DIMENSIONS.



206 Macopin Rd

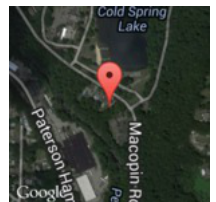

# Reception

Width: 13' 3 1/4"  
Area: 273 sq ft

Length: 20' 6 1/2"  
Perimeter: 67' 7 1/2"

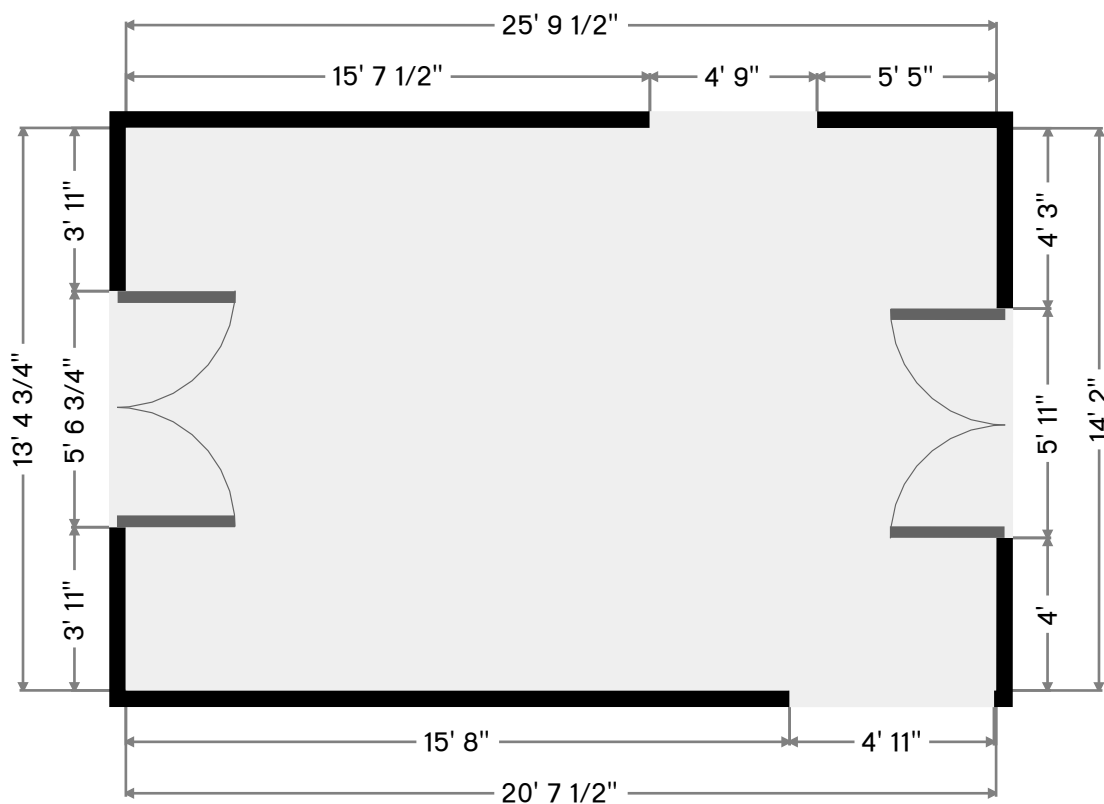
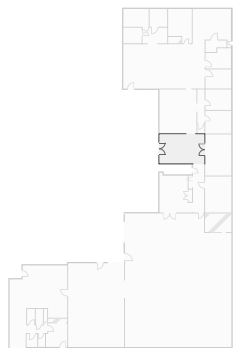

# Other

Width: 1' 7 1/4"  
Area: 10 sq ft

Length: 5' 11 3/4"  
Perimeter: 15' 2 1/4"

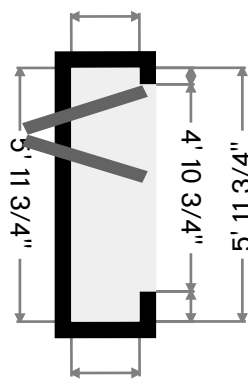
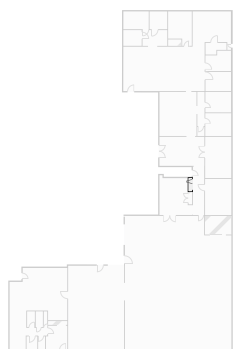

THIS FLOORPLAN IS PROVIDED WITHOUT WARRANTY OF ANY KIND. SENSOPIA DISCLAIMS ANY WARRANTY INCLUDING, WITHOUT LIMITATION, SATISFACTORY QUALITY OR ACCURACY OF DIMENSIONS.



206 Macopin Rd

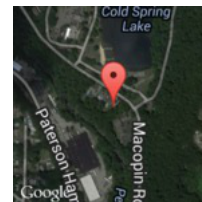

# Corridor

Width: 5' 2"  
Area: 114 sq ft

Length: 22' 1 3/4"  
Perimeter: 54' 7 3/4"

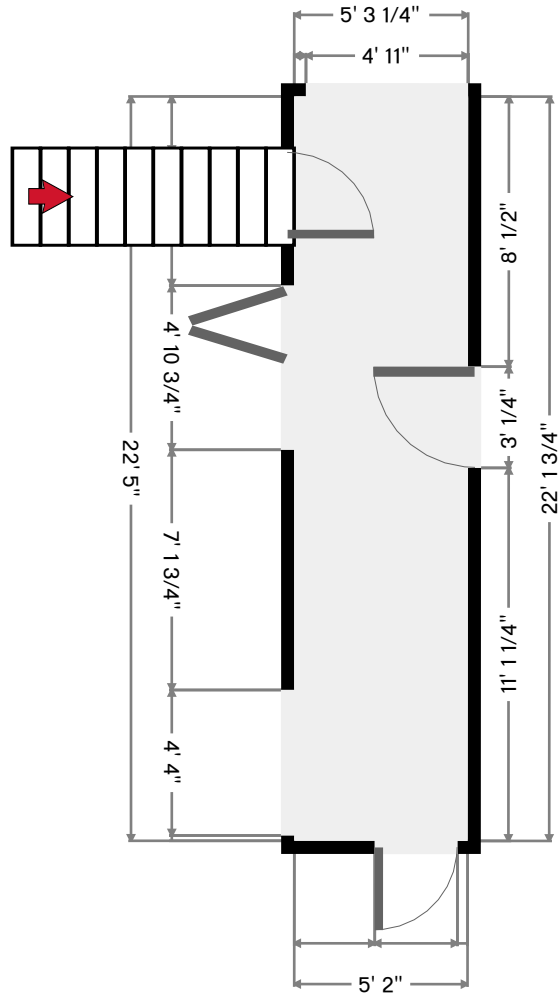
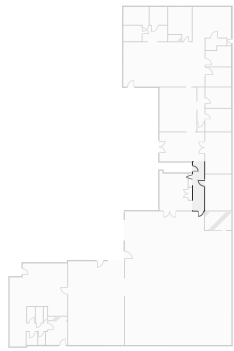

# Conference Room

Width: 11' 11 1/2"  
Area: 225 sq ft

Length: 18' 10 1/2"  
Perimeter: 61' 7 3/4"

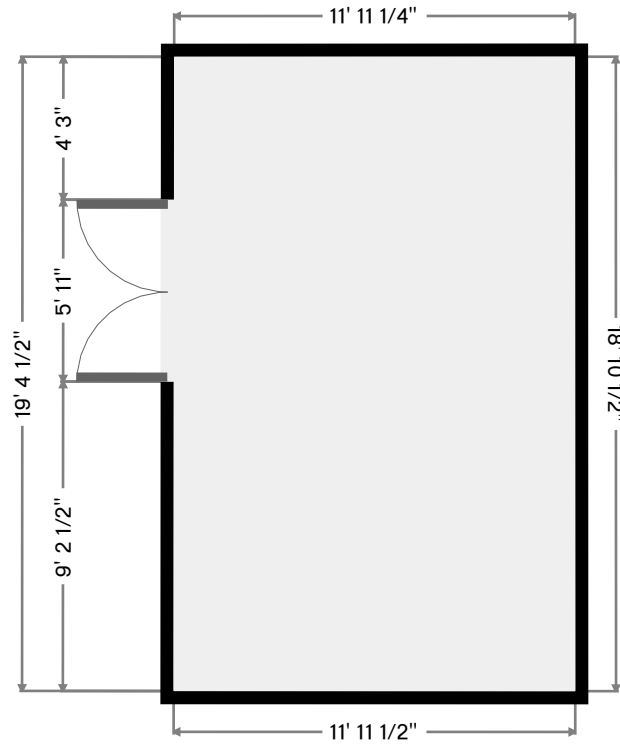
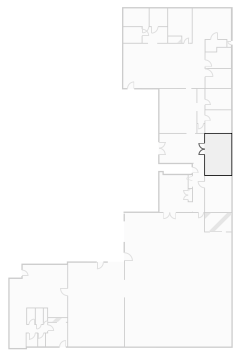

THIS FLOORPLAN IS PROVIDED WITHOUT WARRANTY OF ANY KIND. SENSOPIA DISCLAIMS ANY WARRANTY INCLUDING, WITHOUT LIMITATION, SATISFACTORY QUALITY OR ACCURACY OF DIMENSIONS.



206 Macopin Rd

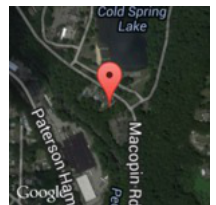

# Private Office

Width: 8' 9 1/4"  
Area: 103 sq ft

Length: 11' 8 1/4"  
Perimeter: 40' 11 1/4"

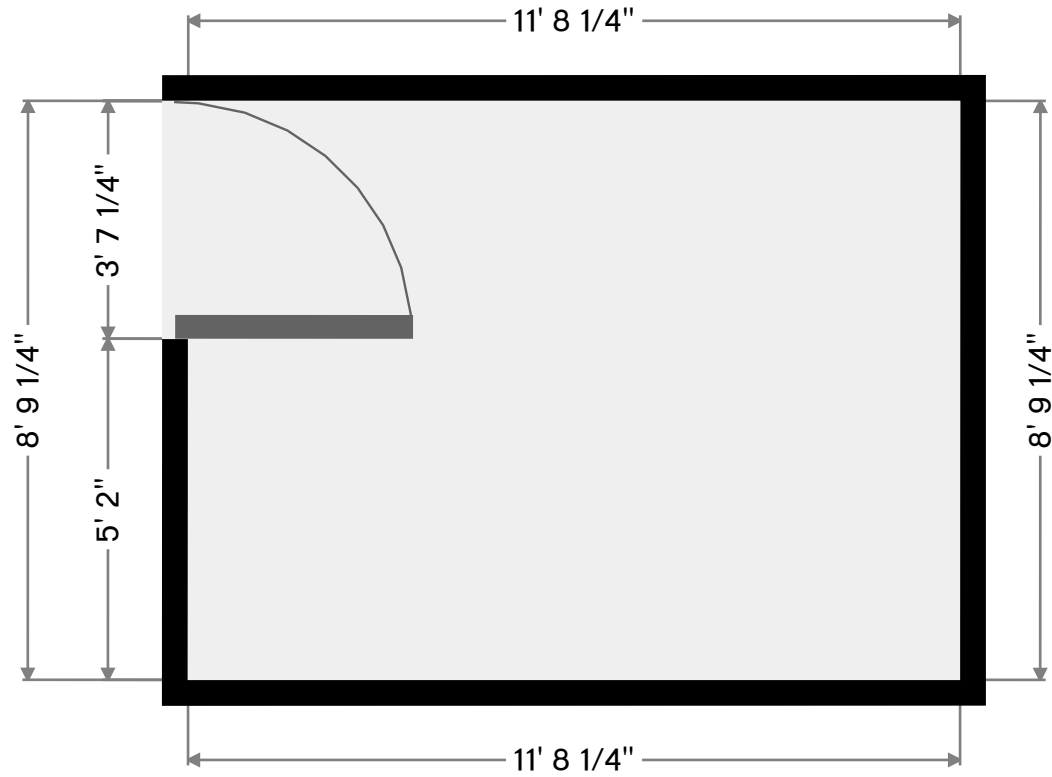
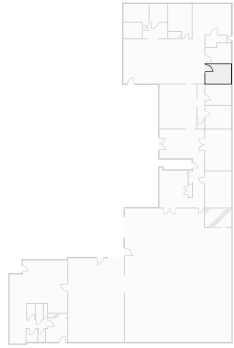

# Private Office

Width: 9' 3 1/2"  
Area: 97 sq ft

Length: 11' 8 3/4"  
Perimeter: 41' 11 3/4"

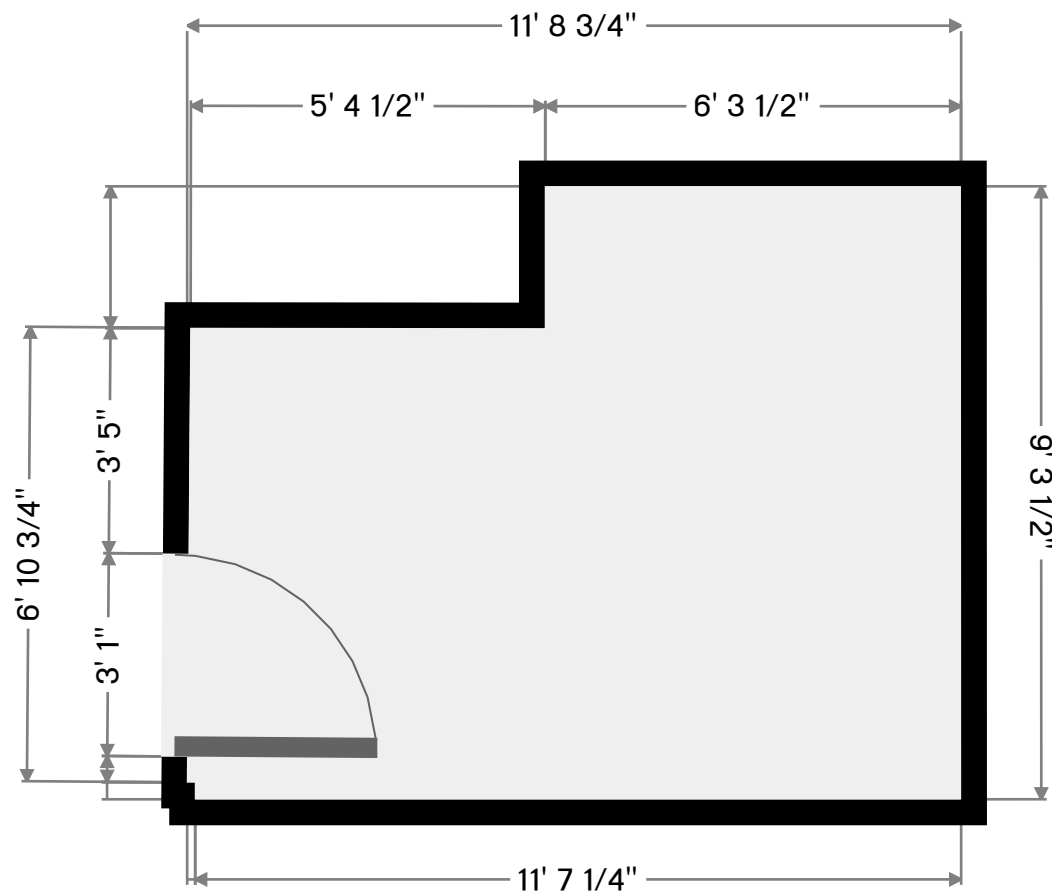
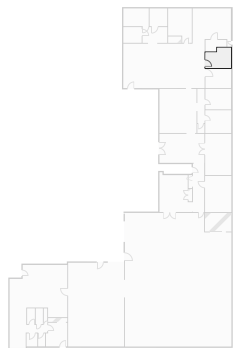

THIS FLOORPLAN IS PROVIDED WITHOUT WARRANTY OF ANY KIND. SENSOPIA DISCLAIMS ANY WARRANTY INCLUDING, WITHOUT LIMITATION, SATISFACTORY QUALITY OR ACCURACY OF DIMENSIONS.



206 Macopin Rd

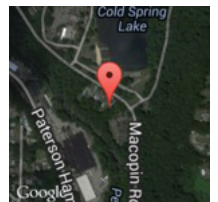

# Other

Width: 5' 4"  
Area: 41 sq ft

Length: 9' 7 1/4"  
Perimeter: 29' 10"

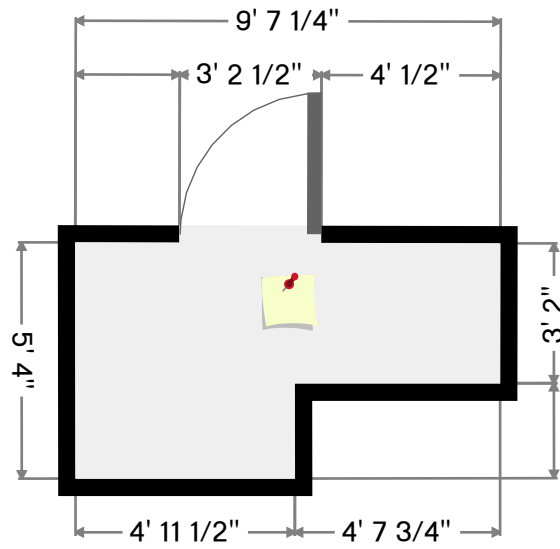
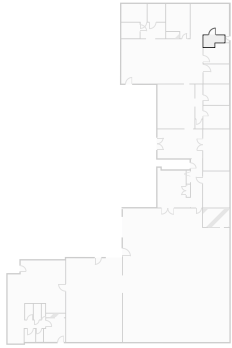

# Private Office

Width: 17' 6 1/2"  
Area: 252 sq ft

Length: 17' 7 1/4"  
Perimeter: 70' 3 1/2"

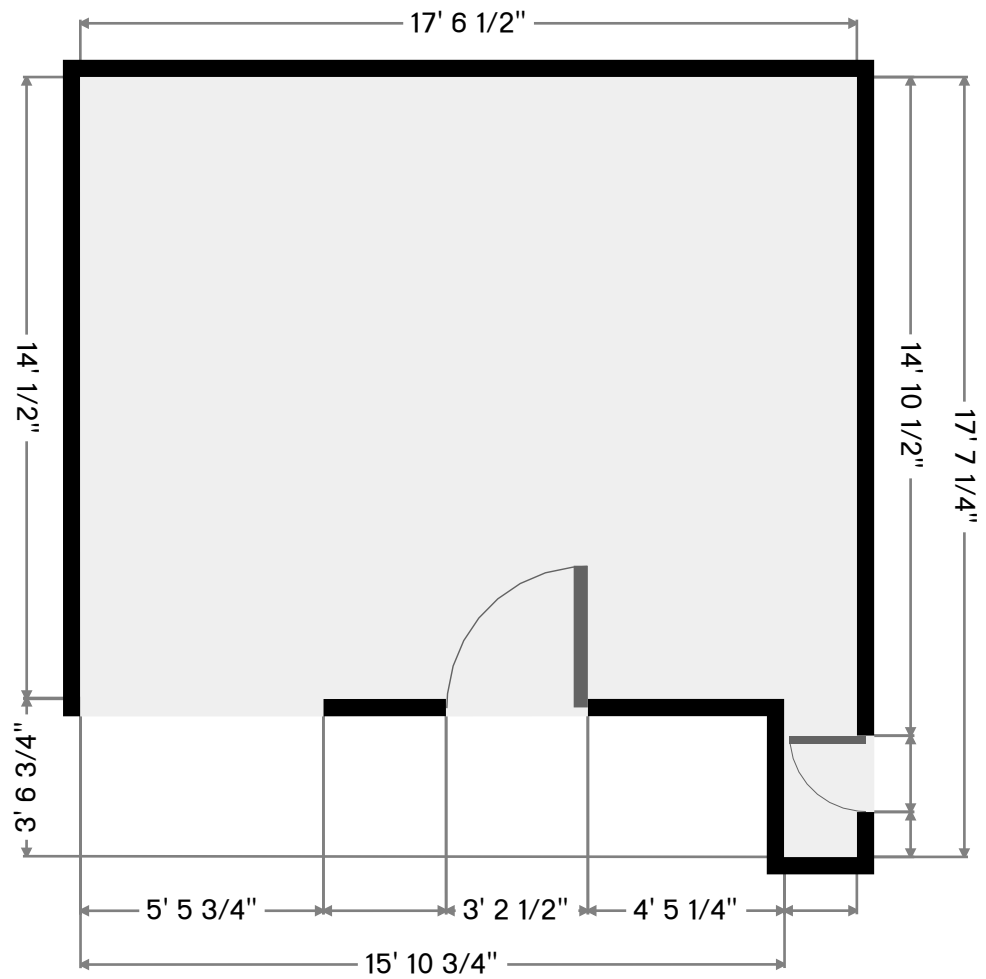
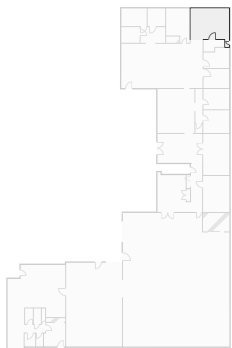

THIS FLOORPLAN IS PROVIDED WITHOUT WARRANTY OF ANY KIND. SENSOPIA DISCLAIMS ANY WARRANTY INCLUDING, WITHOUT LIMITATION, SATISFACTORY QUALITY OR ACCURACY OF DIMENSIONS.



206 Macopin Rd

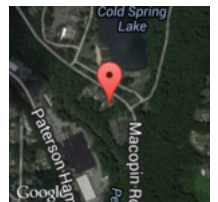

# Kitchenette

Width: 10' 10"  
Area: 149 sq ft

Length: 15' 9"  
Perimeter: 53' 1 3/4"

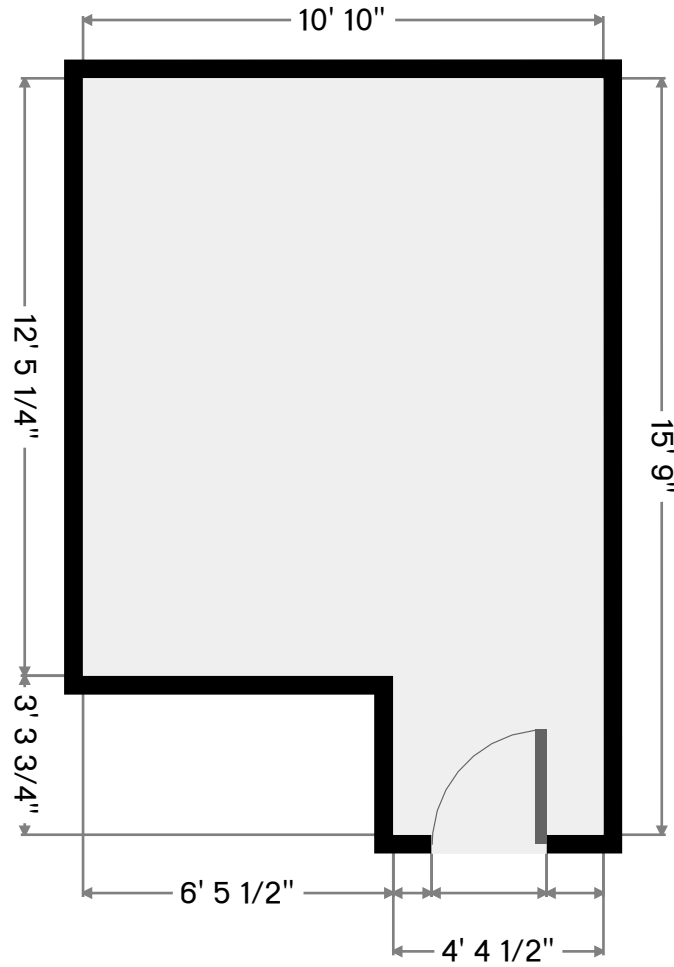
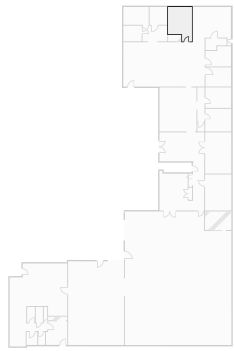

# Private Office

Width: 8' 1"  
Area: 66 sq ft

Length: 8' 1 3/4"  
Perimeter: 32' 5 1/2"

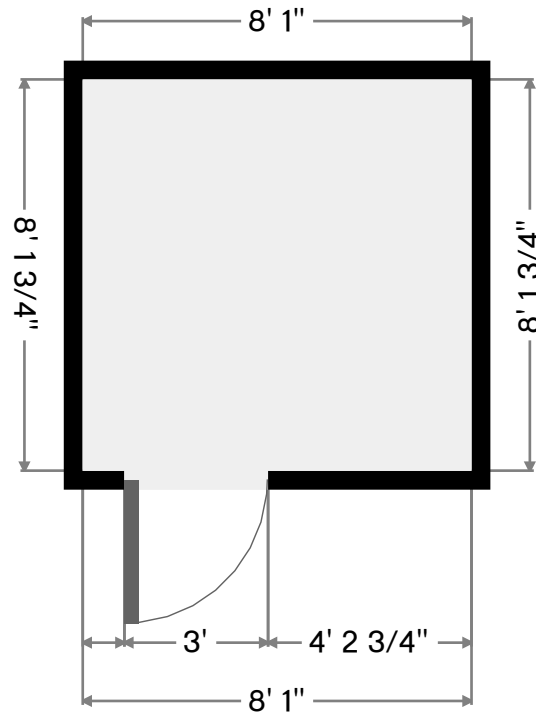
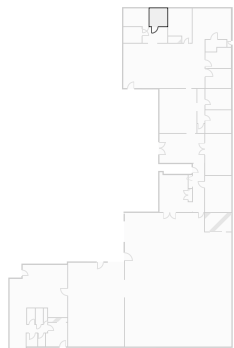

THIS FLOORPLAN IS PROVIDED WITHOUT WARRANTY OF ANY KIND. SENSOPIA DISCLAIMS ANY WARRANTY INCLUDING, WITHOUT LIMITATION, SATISFACTORY QUALITY OR ACCURACY OF DIMENSIONS.



206 Macopin Rd

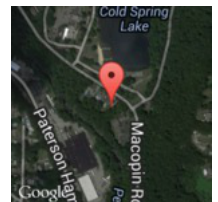

# Private Office

Width: 8' 2"  
Area: 95 sq ft

Length: 11' 7 1/4"  
Perimeter: 39' 6 1/2"

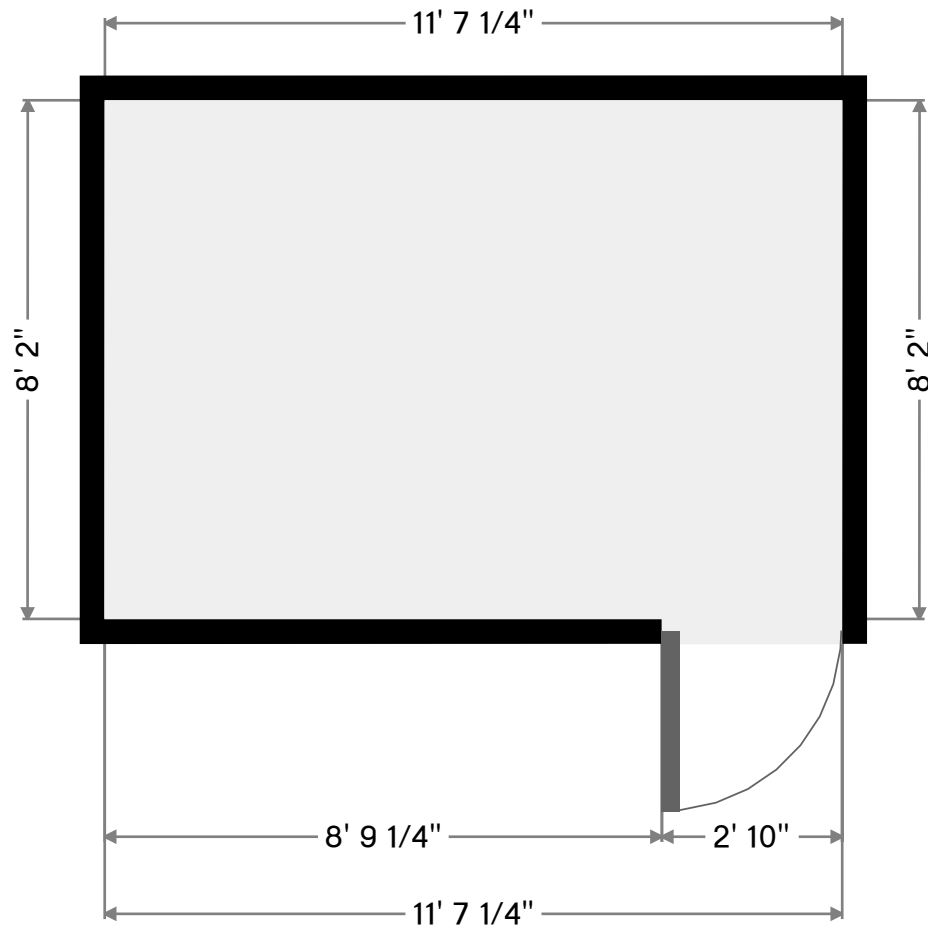
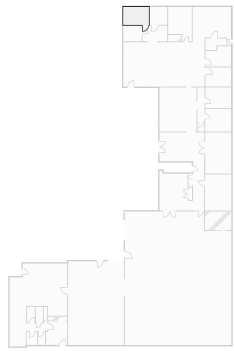

# Other

Width: 7' 2 1/4"  
Area: 60 sq ft

Length: 8' 4 1/2"  
Perimeter: 31' 1 1/2"

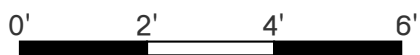
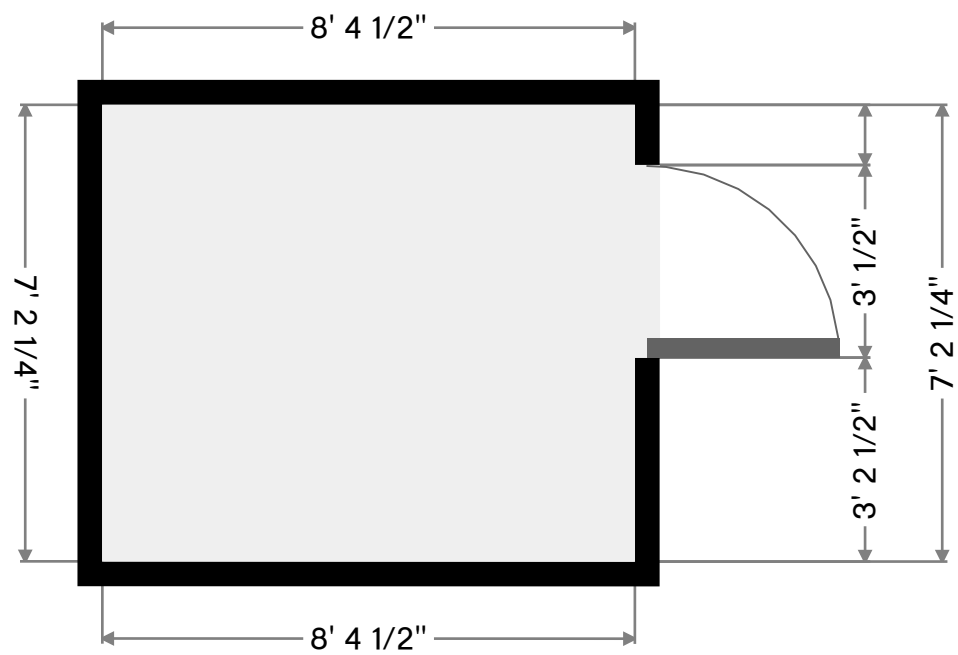
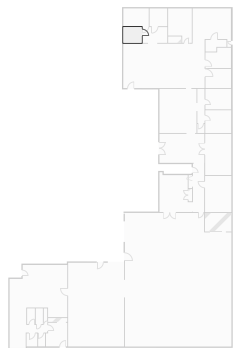

THIS FLOORPLAN IS PROVIDED WITHOUT WARRANTY OF ANY KIND. SENSOPIA DISCLAIMS ANY WARRANTY INCLUDING, WITHOUT LIMITATION, SATISFACTORY QUALITY OR ACCURACY OF DIMENSIONS.



206 Macopin Rd

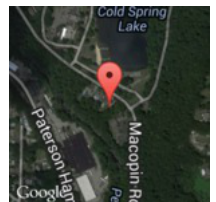

# Other

Width: 7' 2 3/4"  
Area: 82 sq ft

Length: 11' 4 1/4"  
Perimeter: 37' 1 3/4"

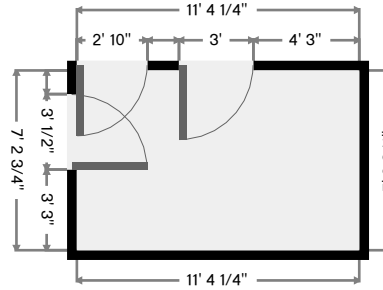
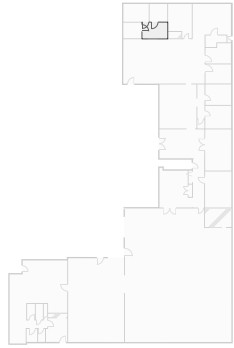

# Other

Width: 22' 3/4"  
Area: 766 sq ft

Length: 37' 3"  
Perimeter: 118' 6 1/4"

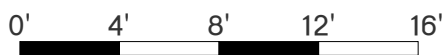
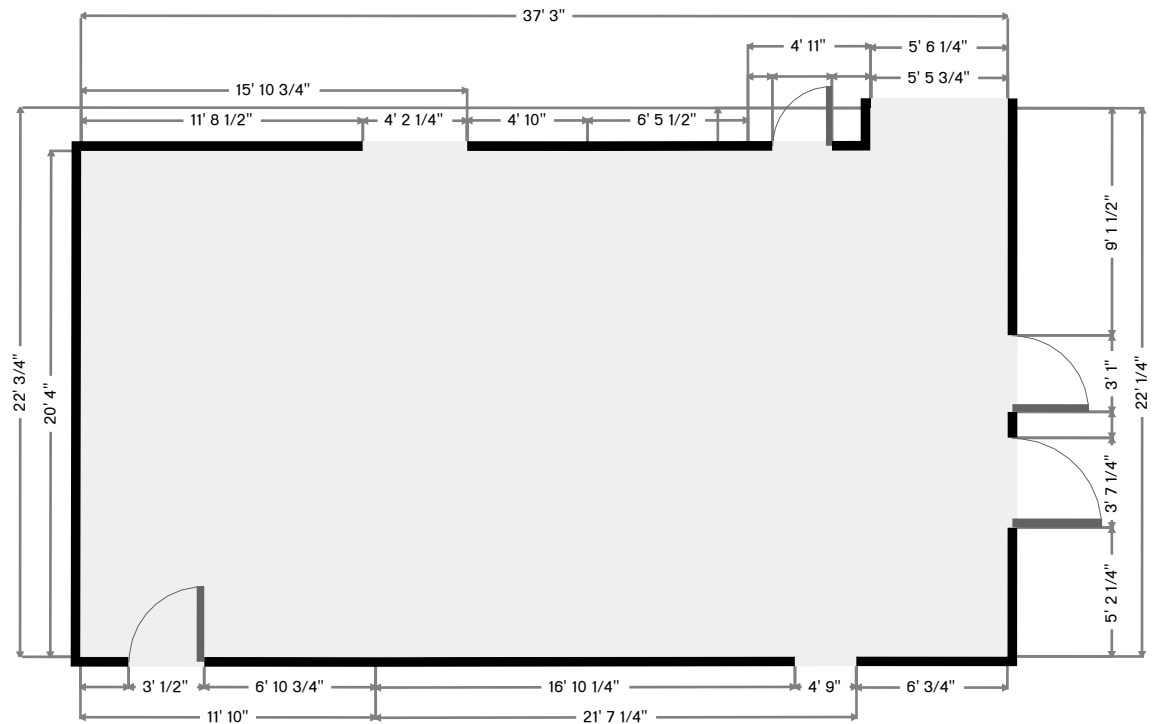
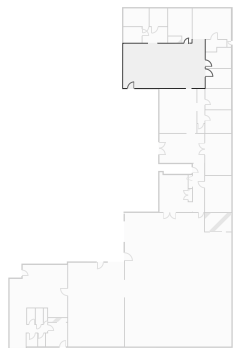

THIS FLOORPLAN IS PROVIDED WITHOUT WARRANTY OF ANY KIND. SENSOPIA DISCLAIMS ANY WARRANTY INCLUDING, WITHOUT LIMITATION, SATISFACTORY QUALITY OR ACCURACY OF DIMENSIONS.



206 Macopin Rd

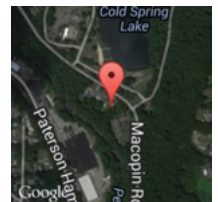



# Training Room

Width: 16' 11 1/4"  
Area: 342 sq ft

Length: 20' 2 1/4"  
Perimeter: 74' 3 1/4"

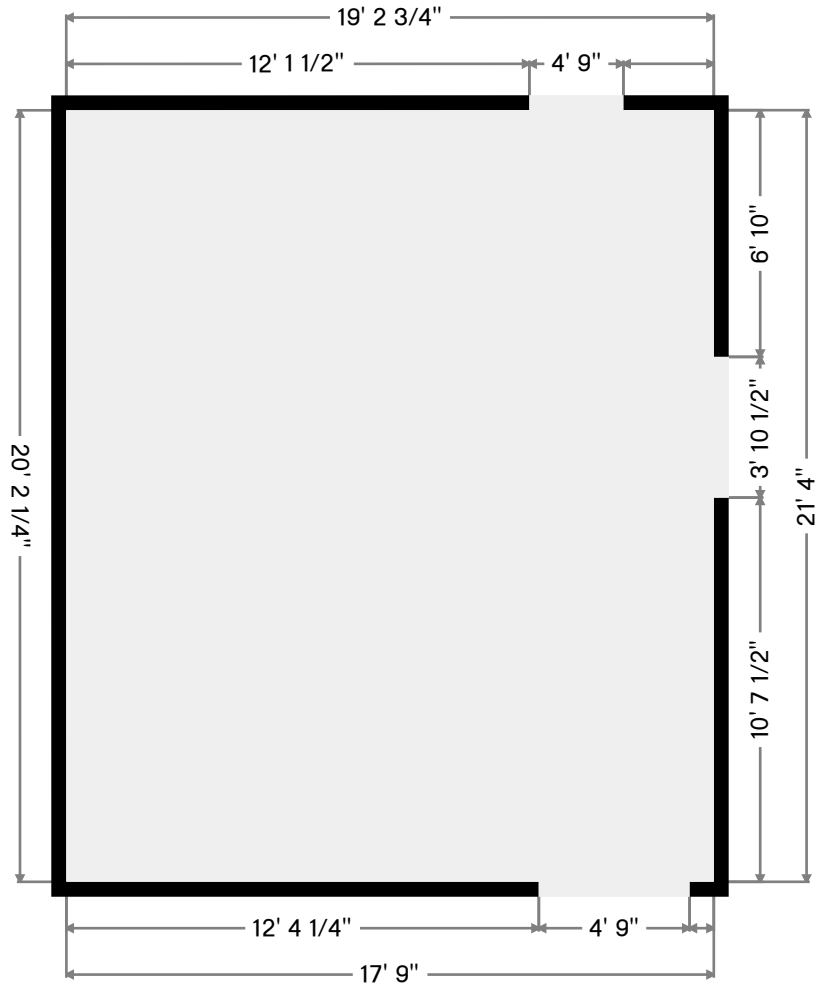
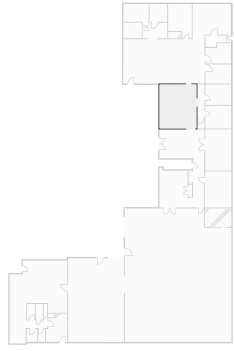

THIS FLOORPLAN IS PROVIDED WITHOUT WARRANTY OF ANY KIND. SENSOPIA DISCLAIMS ANY WARRANTY INCLUDING, WITHOUT LIMITATION, SATISFACTORY QUALITY OR ACCURACY OF DIMENSIONS.



206 Macopin Rd

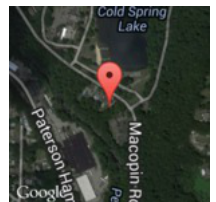

# Basement Warehouse

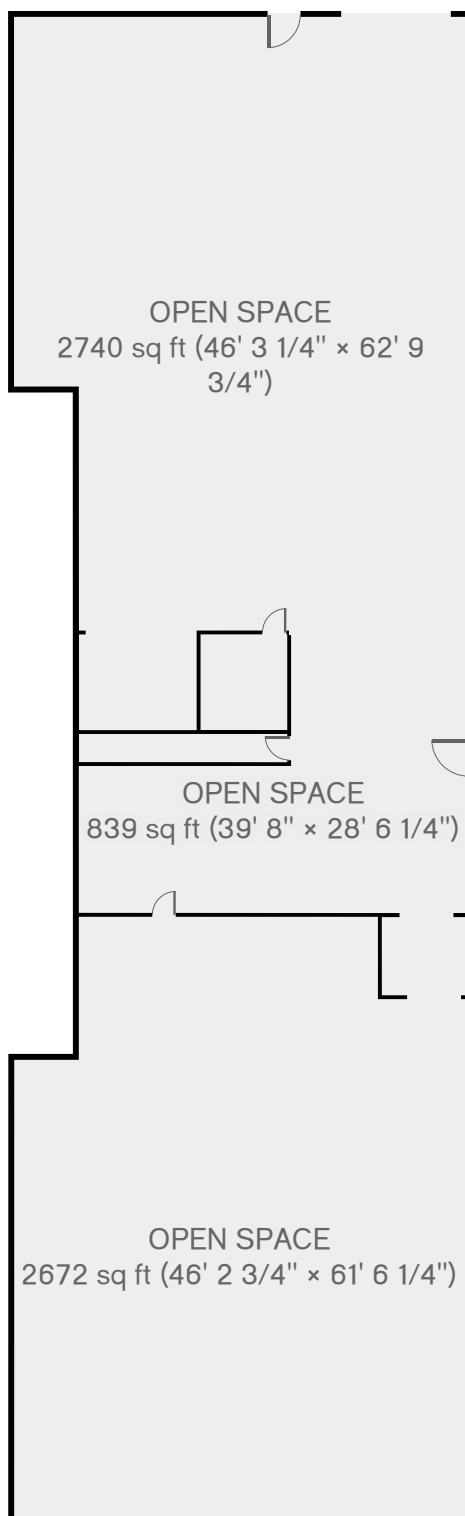

THIS FLOORPLAN IS PROVIDED WITHOUT WARRANTY OF ANY KIND. SENSOPIA DISCLAIMS ANY WARRANTY INCLUDING, WITHOUT LIMITATION, SATISFACTORY QUALITY OR ACCURACY OF DIMENSIONS.



## 206 Macopin Rd

Bloomington, NJ, United States 07403

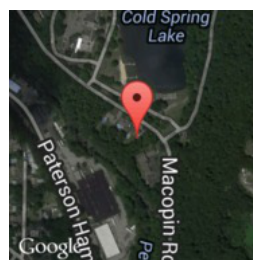

18302 sq ft

2 Floors

36 Rooms

7 Offices

1 conf. room

# Open Space

Width: 46' 3 1/4"  
Area: 2740 sq ft

Length: 62' 9 3/4"  
Perimeter: 218' 1 3/4"

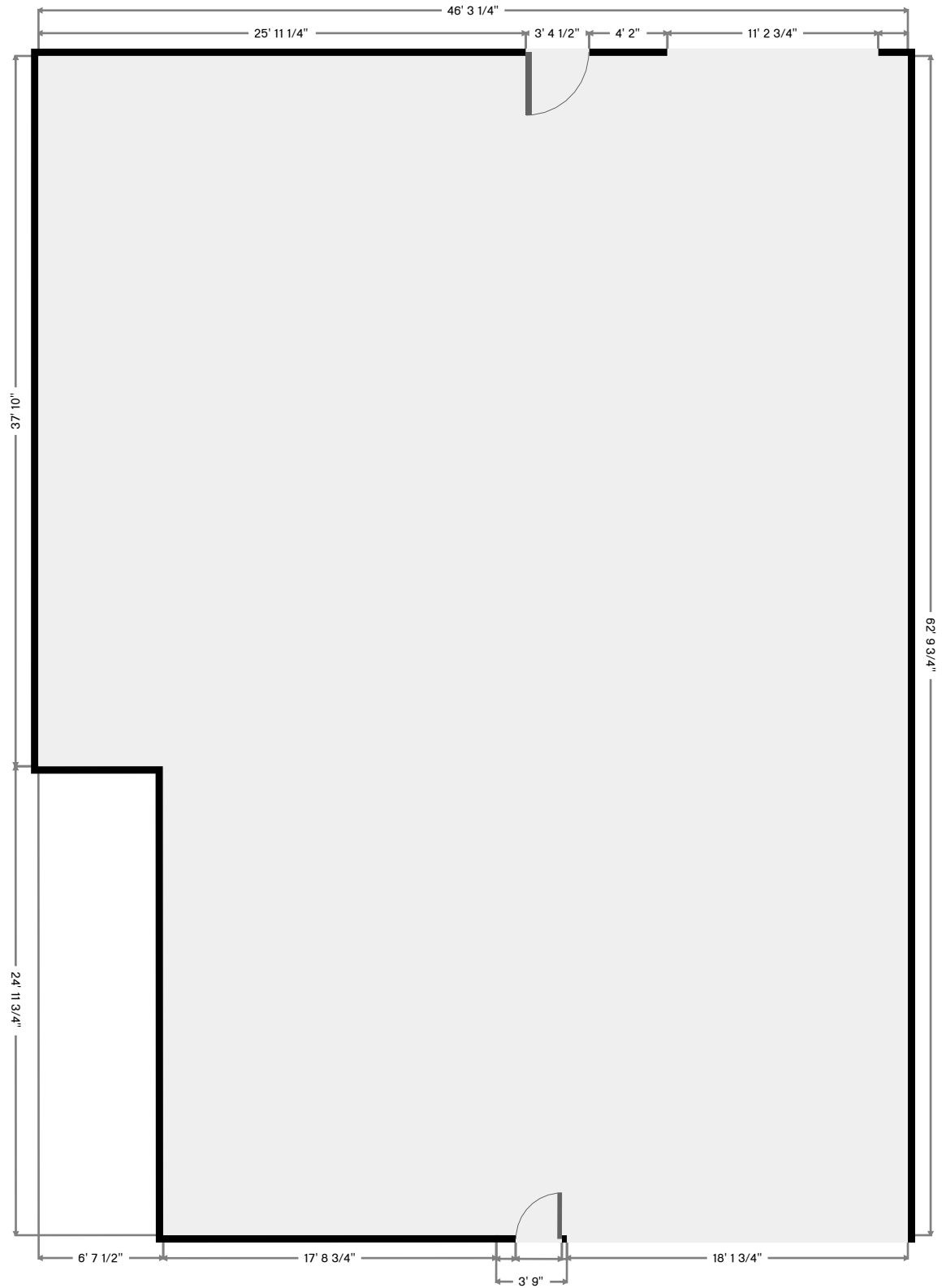
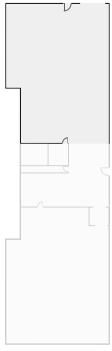

THIS FLOORPLAN IS PROVIDED WITHOUT WARRANTY OF ANY KIND. SENSOPIA DISCLAIMS ANY WARRANTY INCLUDING, WITHOUT LIMITATION, SATISFACTORY QUALITY OR ACCURACY OF DIMENSIONS.



206 Macopin Rd

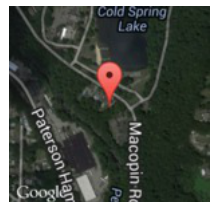

# Open Space

Width: 28' 6 1/4"  
Area: 839 sq ft

Length: 39' 8"  
Perimeter: 136' 3 3/4"

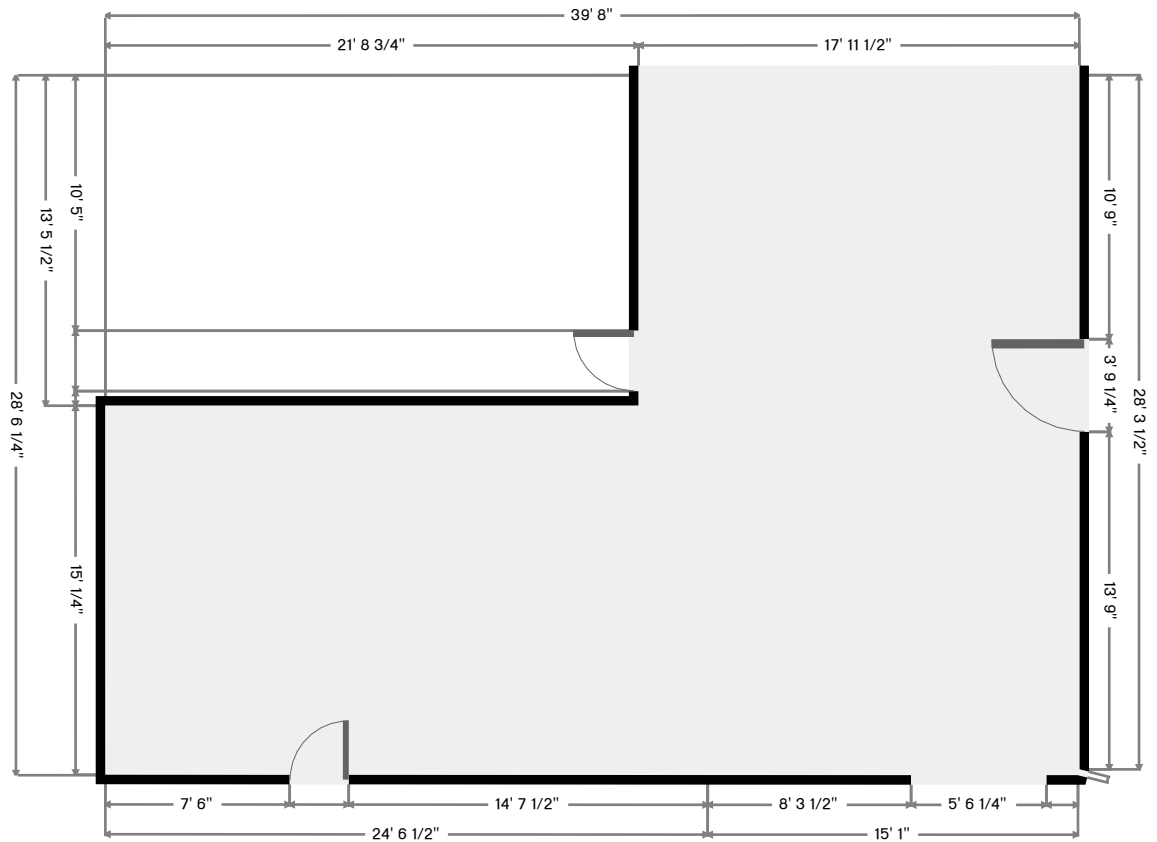
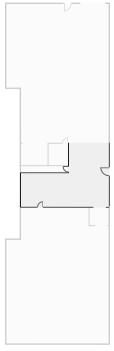

THIS FLOORPLAN IS PROVIDED WITHOUT WARRANTY OF ANY KIND. SENSOPIA DISCLAIMS ANY WARRANTY INCLUDING, WITHOUT LIMITATION, SATISFACTORY QUALITY OR ACCURACY OF DIMENSIONS.



206 Macopin Rd

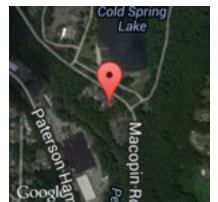

# Other

Width: 2' 10 1/2"  
Area: 61 sq ft

Length: 21' 3 3/4"  
Perimeter: 48' 4 1/2"

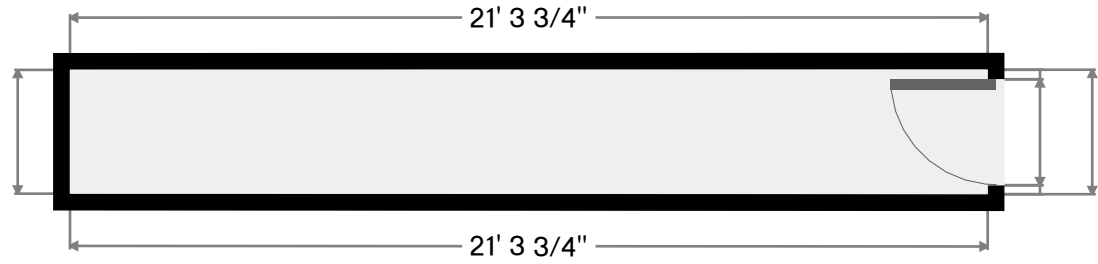
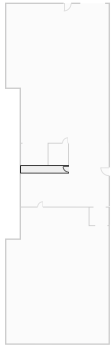

# Other

Width: 8' 10 1/2"  
Area: 87 sq ft

Length: 9' 9 1/2"  
Perimeter: 37' 3 3/4"

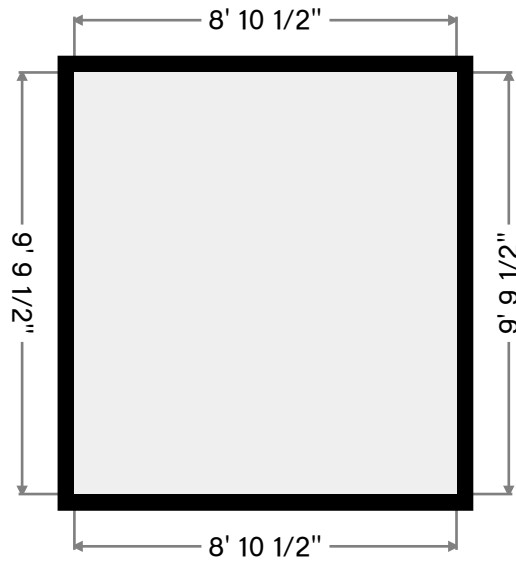
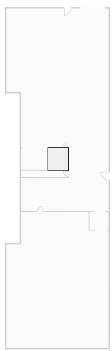

THIS FLOORPLAN IS PROVIDED WITHOUT WARRANTY OF ANY KIND. SENSOPIA DISCLAIMS ANY WARRANTY INCLUDING, WITHOUT LIMITATION, SATISFACTORY QUALITY OR ACCURACY OF DIMENSIONS.



206 Macopin Rd

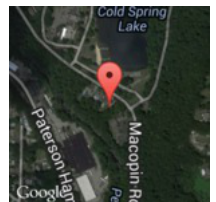

# Private Office

Width: 9' 9 1/2"  
Area: 118 sq ft

Length: 12' 1/2"  
Perimeter: 43' 8"

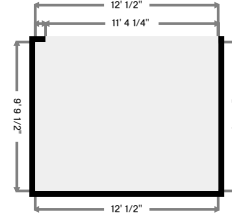
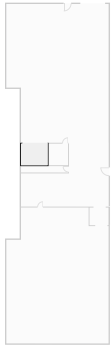

# Open Space

Width: 46' 2 3/4"  
Area: 2672 sq ft

Length: 61' 6 1/4"  
Perimeter: 215' 6 1/4"

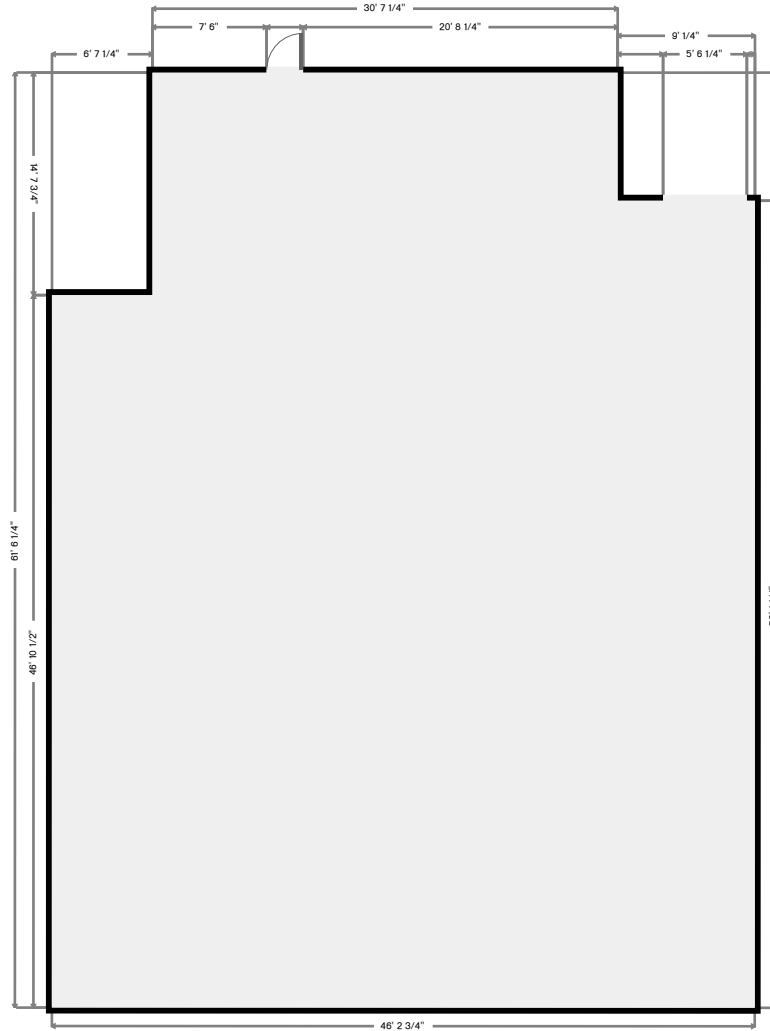
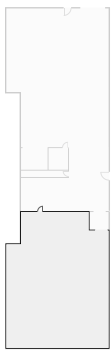

THIS FLOORPLAN IS PROVIDED WITHOUT WARRANTY OF ANY KIND. SENSOPIA DISCLAIMS ANY WARRANTY INCLUDING, WITHOUT LIMITATION, SATISFACTORY QUALITY OR ACCURACY OF DIMENSIONS.



206 Macopin

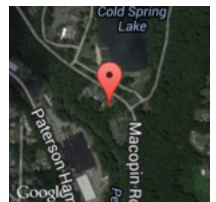

# Other

Width: 8'  
Area: 69 sq ft

Length: 8' 7 1/4"  
Perimeter: 33' 2 1/4"

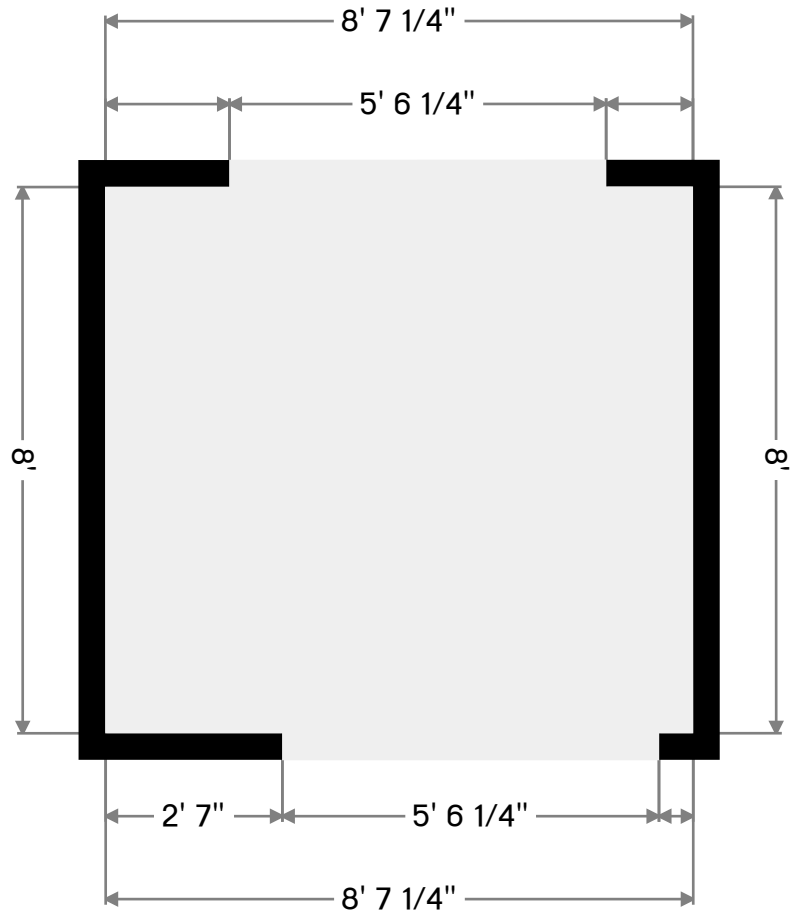

THIS FLOORPLAN IS PROVIDED WITHOUT WARRANTY OF ANY KIND. SENSOPIA DISCLAIMS ANY WARRANTY INCLUDING, WITHOUT LIMITATION, SATISFACTORY QUALITY OR ACCURACY OF DIMENSIONS.



206 Macopin Rd

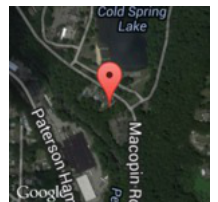



## Plan

Mark out all Internet lines and phone extensions. Locate rack locate phone lines and fax location.

---

THIS FLOORPLAN IS PROVIDED WITHOUT WARRANTY OF ANY KIND. SENSOPIA DISCLAIMS ANY WARRANTY INCLUDING, WITHOUT LIMITATION, SATISFACTORY QUALITY OR ACCURACY OF DIMENSIONS.



206 Macopin Rd

