



**Proposed Front Elevation—Dunsmuir Ave**

**Mixed Use Condominium Conversion & Building Renovation  
Western States Real Estate, LLC**

**June 12, 2020**



508 Chestnut St, Suite 3  
Mt Shasta, CA 96067





**Proposed Right Side Elevation—Pine Street**

**Mixed Use Condominium Conversion & Building Renovation  
Western States Real Estate, LLC**



508 Chestnut St, Suite 3  
Mt Shasta, CA 96067





**Proposed Streetscene—Dunsmuir Avenue**



**Proposed Streetscene—Pine Street**

**Mixed Use Condominium Conversion & Building Renovation  
Western States Real Estate, LLC**



508 Chestnut St, Suite 3  
Mt Shasta, CA 96067





Shasta Ave Frontage



Pine Street Frontage



Main Entry



South Elevation



Dunsmuir Avenue Frontage



Intersection of Dunsmuir Avenue & Pine Street



Arched Storefront Windows at Dunsmuir Avenue Frontage

### Existing Building Details

**Mixed Use Condominium Conversion & Building Renovation  
Western States Real Estate, LLC**



508 Chestnut St, Suite 3  
Mt Shasta, CA 96067





5519  
II-Sis-3-Dmr  
F.N.D. 2-40 Looking N. Pine St, left.

Dunsmuir Avenue Frontage—1940's



Early Photo of Main Entry



Main Entry—1956



Former Window Sign



Dunsmuir Avenue & Pine Street—1920's  
Note that fire escapes have not been installed.

### Historic Building Details

Mixed Use Condominium Conversion & Building Renovation  
Western States Real Estate, LLC



508 Chestnut St, Suite 3  
Mt Shasta, CA 96067





**Existing Raised Island Median**



**Proposed 3-phase Pad Mount Transformer**

Transformer Dimensions:  
6 ft. wide x 4 ft. deep x 5 ft. 1 in. high

**Mixed Use Condominium Conversion & Building Renovation  
Western States Real Estate, LLC**



508 Chestnut St, Suite 3  
Mt Shasta, CA 96067





Main Body Paint:  
Benjamin Moore 1302 Sweet Rosy Brown



Accent/Trim Paint:  
Benjamin Moore 1461 Sterling Silver



Accent/Trim Paint:  
Benjamin Moore 223 El Sereno

Note: Colors shown are approximate due to printing limitations.

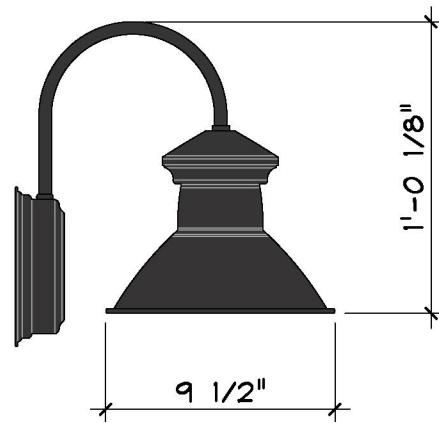

Exterior Sconce LED Lighting:  
Barn Light Electric Cooper LED Wall Sconce  
Color: Textured Black

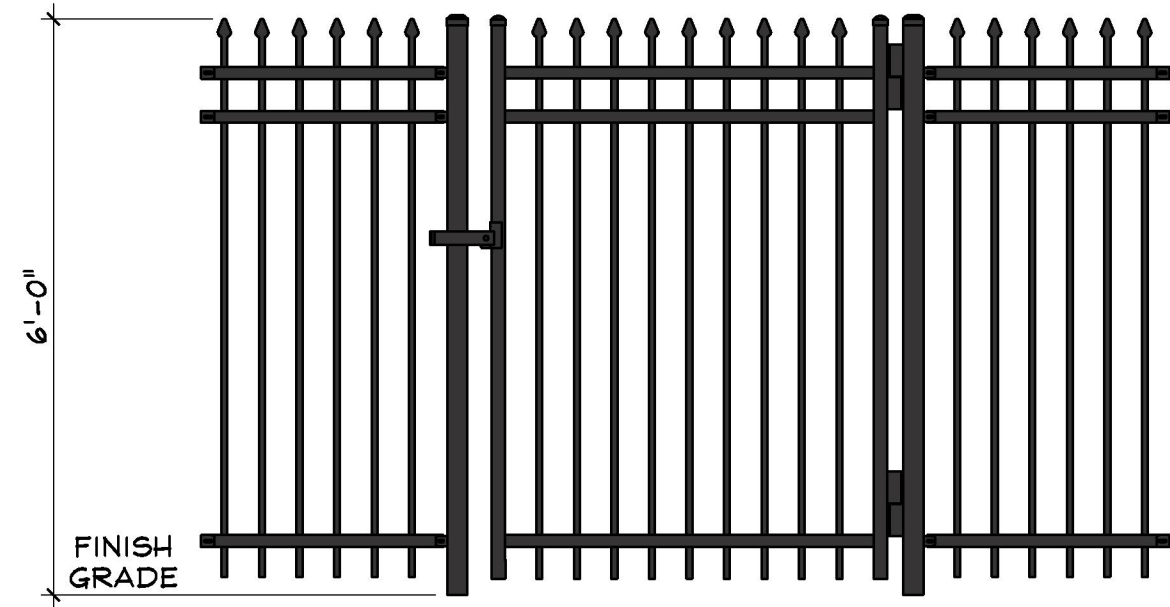
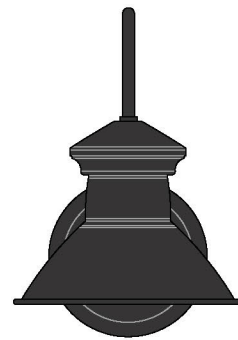

Electric Meter Alcove Security Fence:  
Ameristar Montage Plus Classic or Equal, Welded Ornamental Steel Fence  
4 ft Wide Locking Gate with Lockbox for Power Company Access  
Color: Black

## Colors & Materials

Mixed Use Condominium Conversion & Building Renovation  
Western States Real Estate, LLC



508 Chestnut St, Suite 3  
Mt Shasta, CA 96067



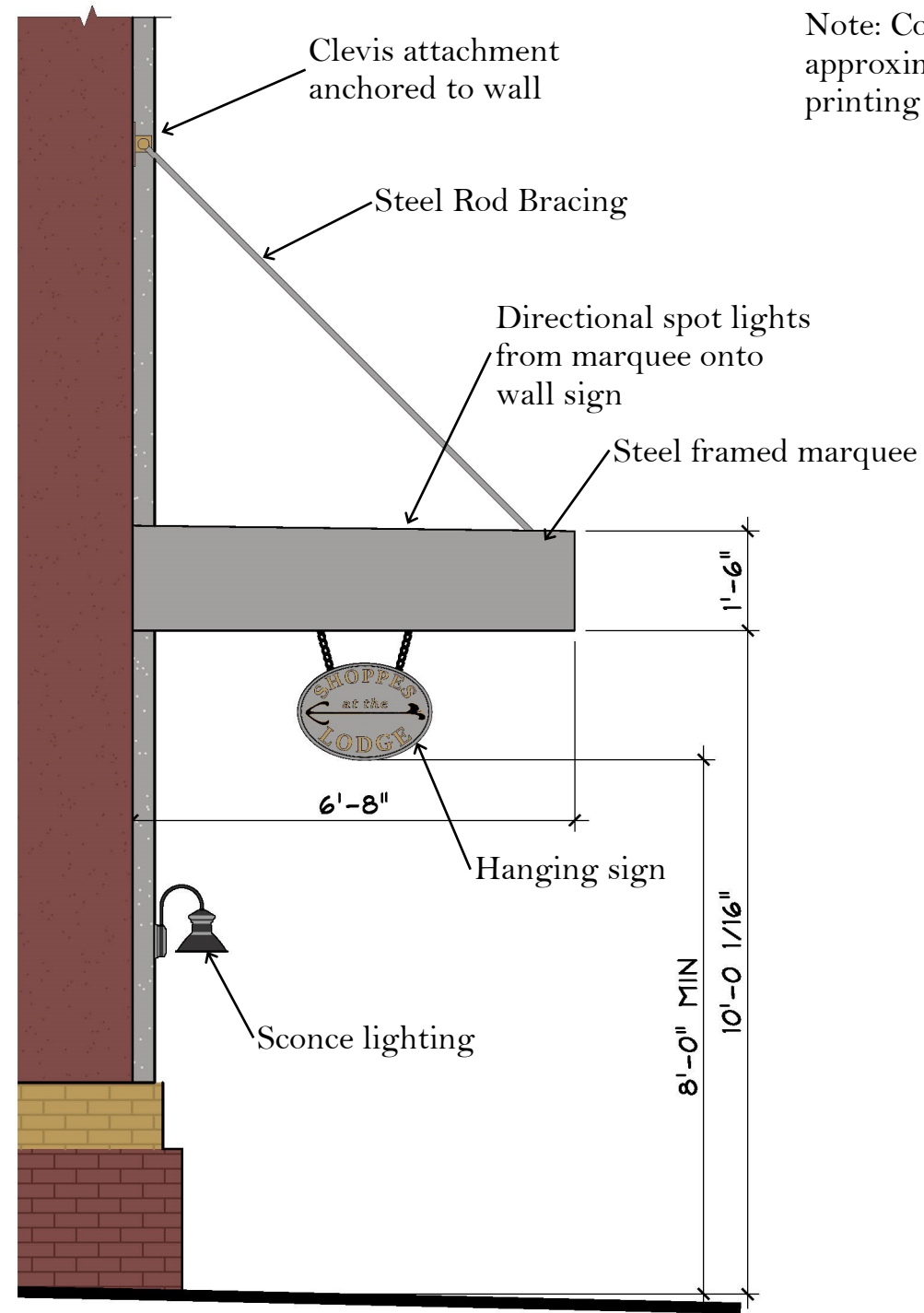

Note: Colors shown are approximate due to printing limitations.

Side Elevation



Front Elevation

### Main Entry Marquee & Sign Details

Mixed Use Condominium Conversion & Building Renovation  
Western States Real Estate, LLC



508 Chestnut St, Suite 3  
Mt Shasta, CA 96067



Note: Colors shown are approximate due to printing limitations.

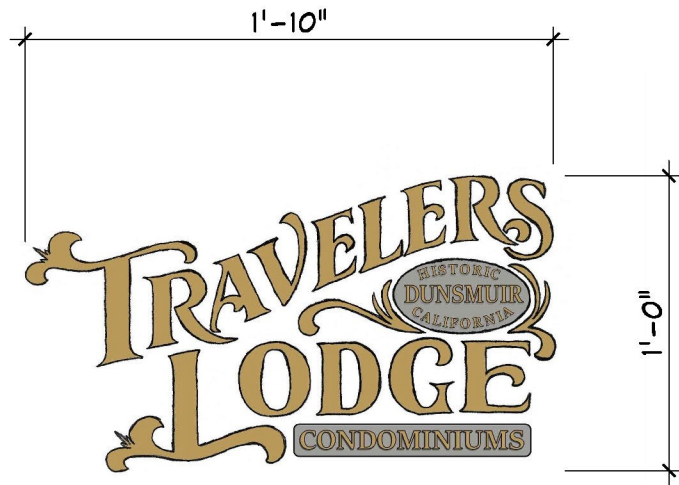

Signage on Glazed Main Entry Door and Pine Street Residential Common Area Glazed Entry Door  
Material: Window Decal



Signage on Face of Building Above Main Entry Marquee  
Material: Painted on Building Stucco

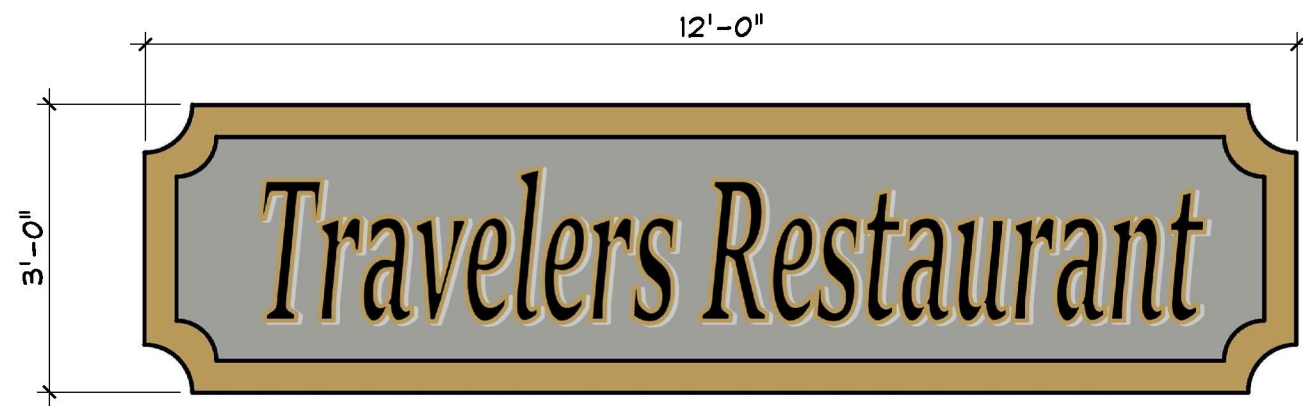

Typical Business Sign Style  
Mounted to Face of Building Above Storefront Glazing  
Sign Copy Per Future Commercial Tenants  
Material: Painted Wood

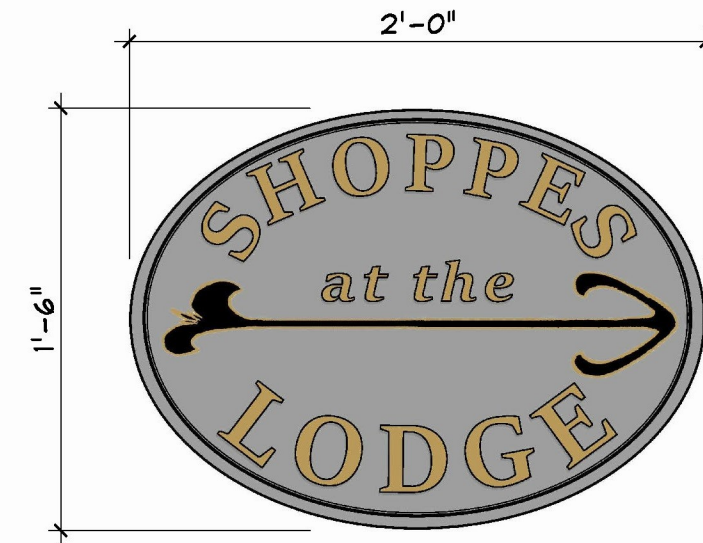

Two-Sided Hanging Sign Under Main Entry Marquee  
(Arrow direction reversed on back side).  
Material: Painted Wood.  
Attachment: Chains to Marquee Structure

### Sign Details

Mixed Use Condominium Conversion & Building Renovation  
Western States Real Estate, LLC



508 Chestnut St, Suite 3  
Mt Shasta, CA 96067