

2012

737 Bridge Road
Northampton, Massachusetts
Mortgagee's Sale of Real Estate

85,000 +/- Sq. Ft. Former Nursing Home on 6 +/- Acres

Highlights:

- 85,000 +/- Sq. Ft. includes 25,000 +/- Sq. Ft. Office Space
- 6 +/- Acres of Land
- 84 Rooms
- 160 Beds
- 100+ Restrooms
- Full Commercial Kitchen and (2) Kitchenettes
- Recently upgraded in 2005 with New Roof, Windows, and Fire Alarm System
- 138 Parking Spots
- Close proximity to Interstate 91
- Zoned URB

Tax Information:

- Assessed Value (Building and Land): \$4,131,300.00
- 2012 Taxes: \$49,395.00 (First installment paid)

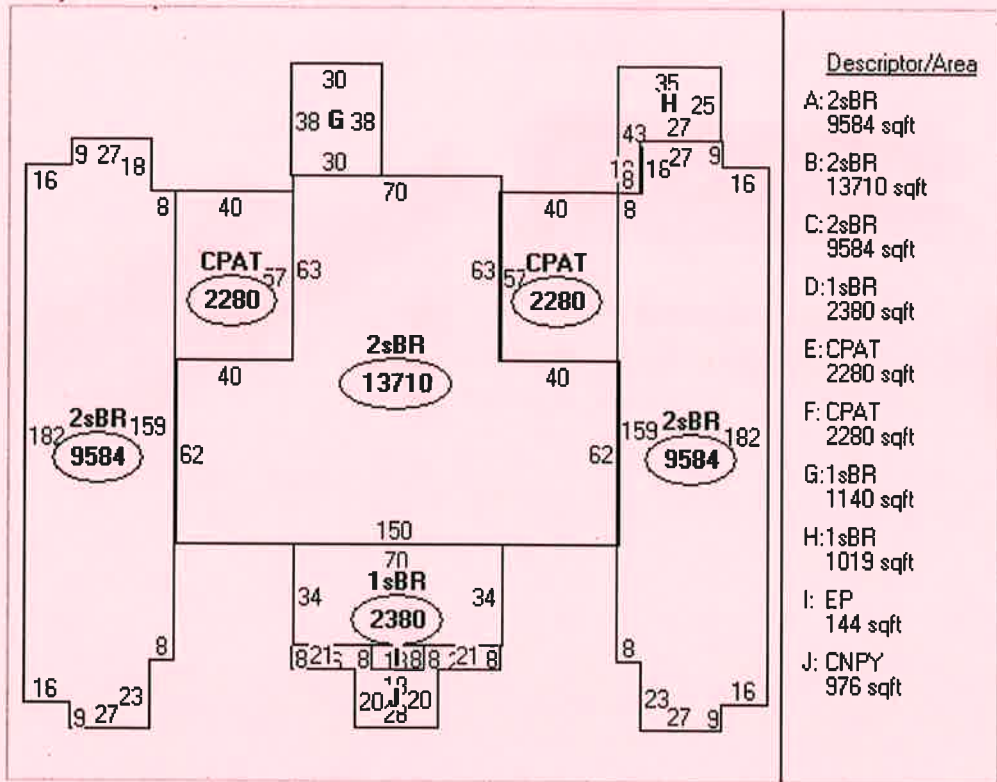

Descriptor/Area	
A:	2sBR 9584 sqft
B:	2sBR 13710 sqft
C:	2sBR 9584 sqft
D:	1sBR 2380 sqft
E:	CPAT 2280 sqft
F:	CPAT 2280 sqft
G:	1sBR 1140 sqft
H:	1sBR 1019 sqft
I:	EP 144 sqft
J:	CNPY 976 sqft

Notice

The information delivered through this on-line database is provided in the spirit of open access to government information and is intended as an enhanced service and convenience for citizens of Northampton, MA.

The providers of this database: CLT, Big Room Studios, and Northampton, MA assume no liability for any error or omission in the information provided here.

Currently All Values Are Finalized For Fiscal Yr 2016.

Comments regarding this service should be directed to: jsarafin@northamptonassessor.us



01/04/12 1:38:53 PM COMMERCIAL/INDUSTRIAL PROPERTY RECORD CARD

PARCEL NO: 16C-048-001 757 BRIDGE RD PLOT: Living Units: 164 Class: C 304 Card # 1 of 1

CURRENT OWNER/ADDRESS: Neighborhood 306.00 FINAL VALUE FLAG: MAN OVERRIDE

NORTHAMPTON HEALTHCARE REAL ESTATE INC 57 MORGAN ST MA 01832

DEED BOOK: B212 DEED PAGE: 109 DEED DATE: 20050404 LAST UPDATE: % 20+07/

LAND DATA TYPE SIZE INFLUENCE FACTORS LAND VALUE LAND VALUE
 PRIME SITE 4,800
 UNDEVELOPED 1,400
 TOTAL ACREAGE: 6.200 TOTAL LAND VALUE: 1,205,940

ASSESSMENT INFORMATION

PRIOR	COST	INCOME	CURRENT
1,205,940	#####	#####	1,205,940
2,925,340	#####	#####	2,684,060
4,131,300	#####	#####	3,700,000
			3,700,000

SALES INFORMATION

DATE	TYPE	PRICE	VALIDITY
20050404	LAND + BLD	2,752,000	I

FINAL VALUE FLAG: MAN OVERRIDE

DATE	TYPE	PRICE	VALIDITY
20050404	LAND + BLD	2,752,000	I

ASSESSMENT INFORMATION

PRIOR	COST	INCOME	CURRENT
1,205,940	#####	#####	1,205,940
2,925,340	#####	#####	2,684,060
4,131,300	#####	#####	3,700,000
			3,700,000

SALES INFORMATION

DATE	TYPE	PRICE	VALIDITY
20050404	LAND + BLD	2,752,000	I

FINAL VALUE FLAG: MAN OVERRIDE

DATE	TYPE	PRICE	VALIDITY
20050404	LAND + BLD	2,752,000	I

ASSESSMENT INFORMATION

PRIOR	COST	INCOME	CURRENT
1,205,940	#####	#####	1,205,940
2,925,340	#####	#####	2,684,060
4,131,300	#####	#####	3,700,000
			3,700,000

SALES INFORMATION

DATE	TYPE	PRICE	VALIDITY
20050404	LAND + BLD	2,752,000	I

FINAL VALUE FLAG: MAN OVERRIDE

DATE	TYPE	PRICE	VALIDITY
20050404	LAND + BLD	2,752,000	I

DIST APPROACH DETAIL:

LEVELS	USE	E WALL	HEATING	A/C	AREA	SF RATE	RCM	% GD	RCMLD
01 TO 01	54	BRK/CONC BLK	HV/STEAM	CENTRAL	35258	100.21	3,532,930	.47	1,660,480
02 TO 02	54	BRK/CONC BLK	HV/STEAM	CENTRAL	56078	92.09	3,027,670	.47	1,423,010
03 TO 03	84	BRK/CONC BLK	HV/STEAM	CENTRAL	2159	53.95	116,420	.32	37,260
TO			NONE	NONE					
TO			NONE	NONE					
TO			NONE	NONE					
TO			NONE	NONE					

BUILDING # 1
 YEAR BUILT 1971
 # UNITS 164
 QUALITY GRADE C+

EFFICIENCIES
 # 1-BEDROOMS
 # 2-BEDROOMS
 # 3-BEDROOMS

OUTBUILDING/YARD ITEM DETAIL:

DESCRIPTION	WIDTH	LENGTH OR SIZE	QUAN.	YEAR BUILT	PHYS. COND.	FUNC. UTIL.	% GD	VALUE
PA1		30000	1	1971	NORMAL	NORMAL		44,630
CP1		400	1	1981	NORMAL	NORMAL		4,280
RS1		80	1	1978	NORMAL	NORMAL		720
AP1		2200	1	1971	NORMAL	NORMAL		27,490

OTHER IMPROV
 TOTAL OBJ/YARD VALUE: 77,120

INCOME APPROACH SUMMARY:
 TOTAL RENTABLE SQUARE FEET:
 INCOME ADJUSTMENT

INCOME INDICATED VALUE:

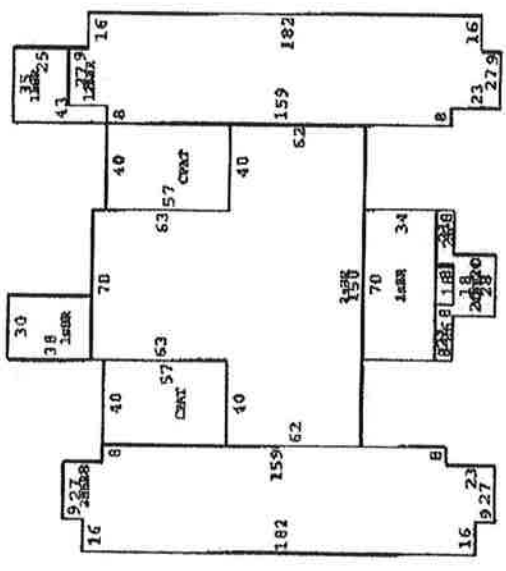

Northampton, MA : Commercial Property Record Card

[[Back to Search Results](#)]

[[Start a New Search](#)] [[Help with Printing](#)]

Search For Properties

Parcel ID	Name	Street Name
18c-048-001		BRIDGE RD

Parcel ID	Card	Routing No	Location	Zoning	State Class	Acres
18C-048-001	1		737 BRIDGE RD		304 - n/a	6.200

Living Units
164

Owner Information

Bais Pinchos

Property Picture

[No Picture Available]

Deed Information

Book/Page: 10850/283
Deed Date: 2012/03/26

Building Information

Building No: 1
Year Built: 1971
No of Units: 164
Structure Type: Nursing Home
Grade: C+
Identical Units: 1

2016

Valuation

Land: \$1,691,170
Building: \$1,907,800
Total: \$3,598,970
Net Assessment: \$0

Sales History

Book/Page	Date	Price	Type	Validity
n/a	2012/03/26	\$2,950,000	Land + Bldg	L
n/a	2005/04/04	\$2,752,000	Land + Bldg	I

Out Building Information

Structure Code	Width	Lgth/SqFt	Year	RCNLD
Asphalt Parking			1971	\$44,630
Canopy Econ			1981	\$4,280
Utility Frame			1976	\$720

Exterior/Interior Information

Levels	Size	Use Type	Ext. Walls	Const. Type	Partitions	Heating	A/C	Plumbing	Condition	Func.	Utility	Unadj.	RCNLD
01-01	n/a	Nursing Home	Brk/Conc Blk	Fire Resist	Normal	Hw/Steam	Central	Normal	Fair	Poor		628080	
02-02	n/a	Nursing Home	Brk/Conc Blk	Fire Resist	Normal	Hw/Steam	Central	Normal	Fair	Poor		538250	
01-01	n/a	Multi-Use Storage	Brk/Conc Blk	Fire Resist	Normal	Hw/Steam	None	Normal	Fair	Poor		20700	

Building Sketch