

THE BLACK SQUIRREL TURNKEY RESTAURANT/BAR FOR SALE

MPN
MALLIN PANCHELLI NADEL
REALTY

3749-51 MIDVALE AVE EAST FALLS, PHILADELPHIA 19129



MPN
MALLIN PANCHELLI NADEL
REALTY

1601 WALNUT ST, PHILADELPHIA, PA 19102 215.413.4900 ■ www.mpnrealty.com

3749-51 MIDVALE AVE

East Falls, Philadelphia 19129

Introduction

MPN Realty, Inc. is pleased to present the exclusive sale of 3749-51 Midvale Ave., The Black Squirrel Restaurant and Bar. The sale presents a unique opportunity for a restaurant/ bar owner, as it includes the real estate, liquor license, FF&E, and business, making this a turnkey operation. The 2-story building, currently consists of a full commercial kitchen, 66 seats inside, 16 seats on the outdoor patio, and has potential to add both more interior and exterior seats. The property was renovated in the past couple of years, containing new electrical, plumbing and mechanical systems.

Located in East Falls, the property has fantastic exposure with 38' of frontage on Midvale Ave. East Falls is a Philadelphia oasis along the Schuylkill River, with a dense residential population, and a vibrant commercial scene with businesses such as In Riva, LeBus, Taqueria Cresta, and East Falls Farmers Market. The site provides easy access to Center City via Kelly Drive, and the Main Line via I-76.

[Click to View Full List of FF&E](#)

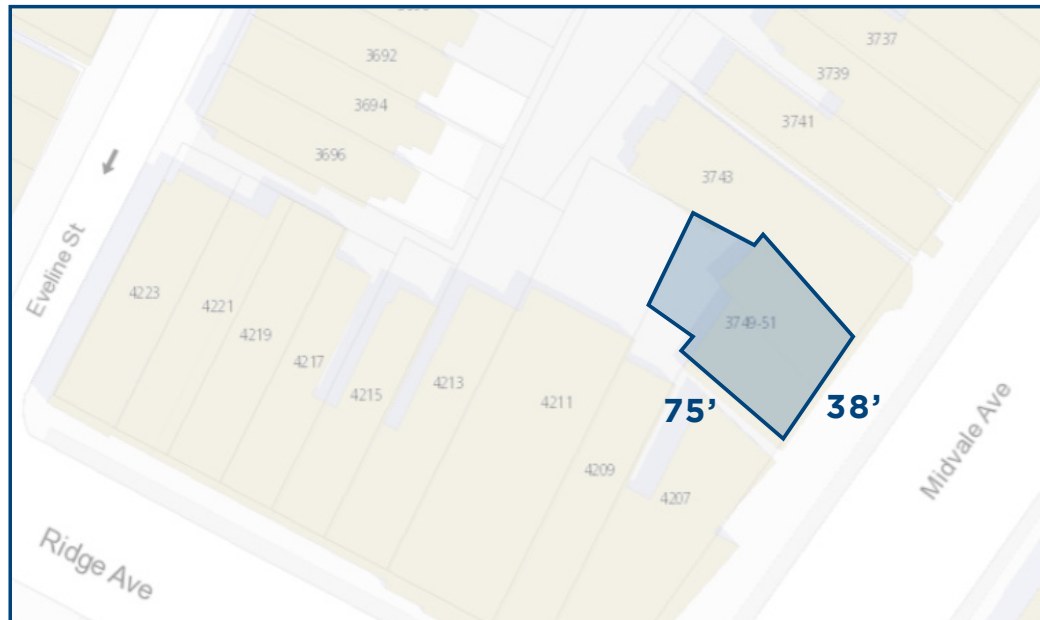

3749-51 MIDVALE AVE

East Falls, Philadelphia 19129

Property Overview

PROPERTY OVERVIEW	
Sale Price:	
Real Estate	\$990,000
FF&E / Business	\$225,000
Liquor License	\$180,000
Total	\$1,395,000
Year Built (City of Philadelphia)	1920
Number of Floors	2 + basement
Kitchen	Commercial Kitchen with 11' Hood
FF&E	CLICK TO VIEW FULL LIST OF FF&E
Refrigeration	(2) Walk In Coolers
Heat	Gas Forced Hot Air
Dosmestic Hot Water	Gas
Cooking	Gas
Air Conditioning	Central Air
Flooring	Hardwood and Tile
Number of Bars	(1) on first floor
Restrooms	First floor - (1) ADA Restrooms Second Floor - (2) Restrooms
Outdoor space	Front patio and rear deck off of the second floor
Lot Area (City of Philadelphia)	2,828 SF
Building Area (City of Philadelphia)	4,550 SF
Lot Size (City of Philadelphia)	38' x 75'
Street Frontages	38' on Midvale
RE Tax Assesment 2024	\$379,300
RE Tax 2024	\$5,309
Zoning	CMX-2.5

KEN MALLIN 215.803.3200 ■ kmallin@mpnrealty.com

NADIA BILYNSKY 267.441.0601 ■ nbilynsky@mpnrealty.com

3

3749-51 MIDVALE AVE

East Falls, Philadelphia 19129

Photos - [\(Click to View More\)](#)



KEN MALLIN 215.803.3200 ■ kmallin@mpnrealty.com

NADIA BILYNSKY 267.441.0601 ■ nbilynsky@mpnrealty.com

3749-51 MIDVALE AVE

East Falls, Philadelphia 19129

Photos - [\(Click to View More\)](#)



KEN MALLIN 215.803.3200 ■ kmallin@mpnrealty.com

NADIA BILYNSKY 267.441.0601 ■ nbilynsky@mpnrealty.com

3749-51 MIDVALE AVE

East Falls, Philadelphia 19129

Site Plan ([Click to Enlarge](#))

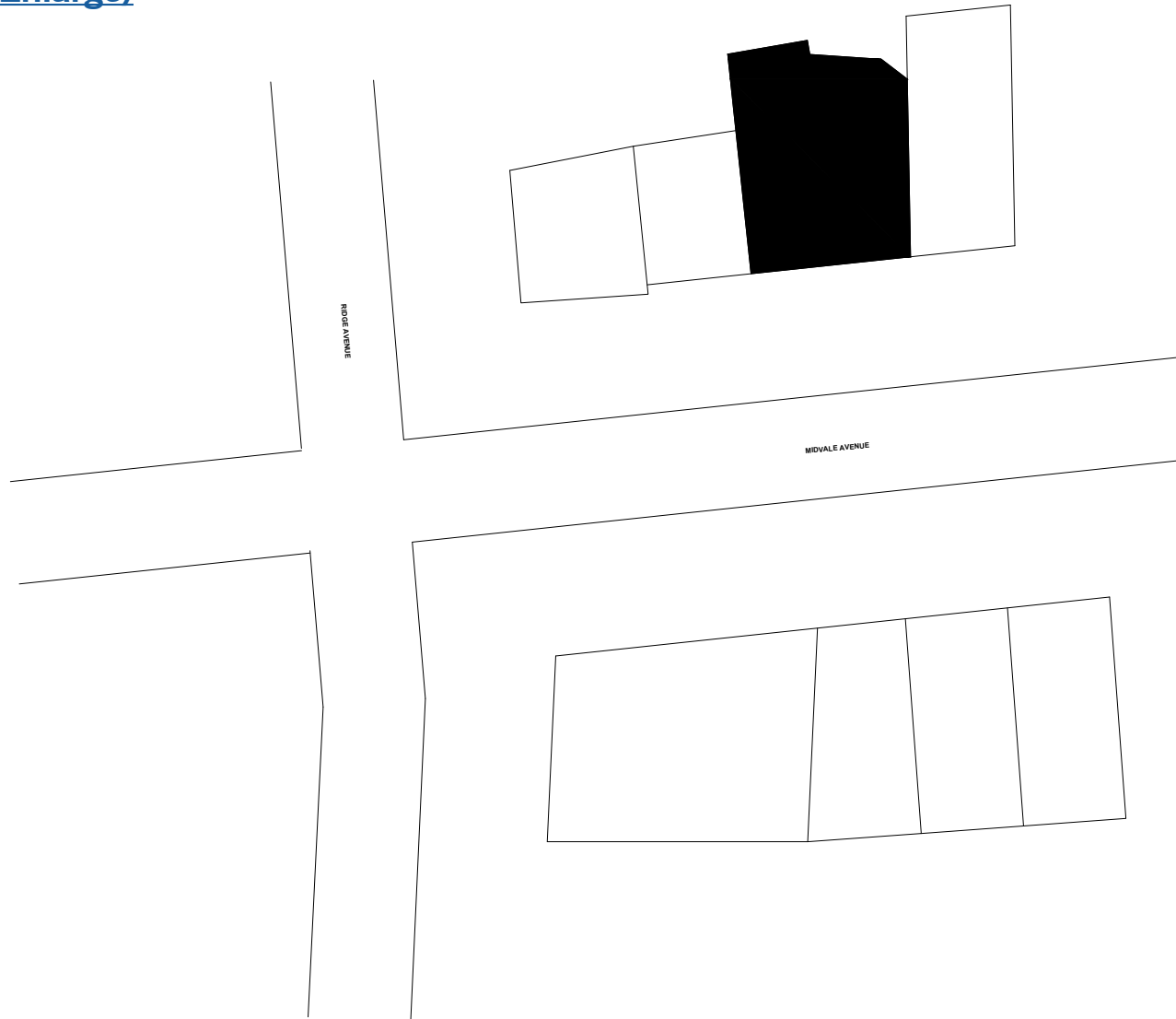

***Plans not done by Architect*

KEN MALLIN 215.803.3200 ■ kmallin@mpnrealty.com

NADIA BILYNSKY 267.441.0601 ■ nbilynsky@mpnrealty.com

3749-51 MIDVALE AVE

East Falls, Philadelphia 19129

First Floor Plumbing Plan [\(Click to Enlarge\)](#)

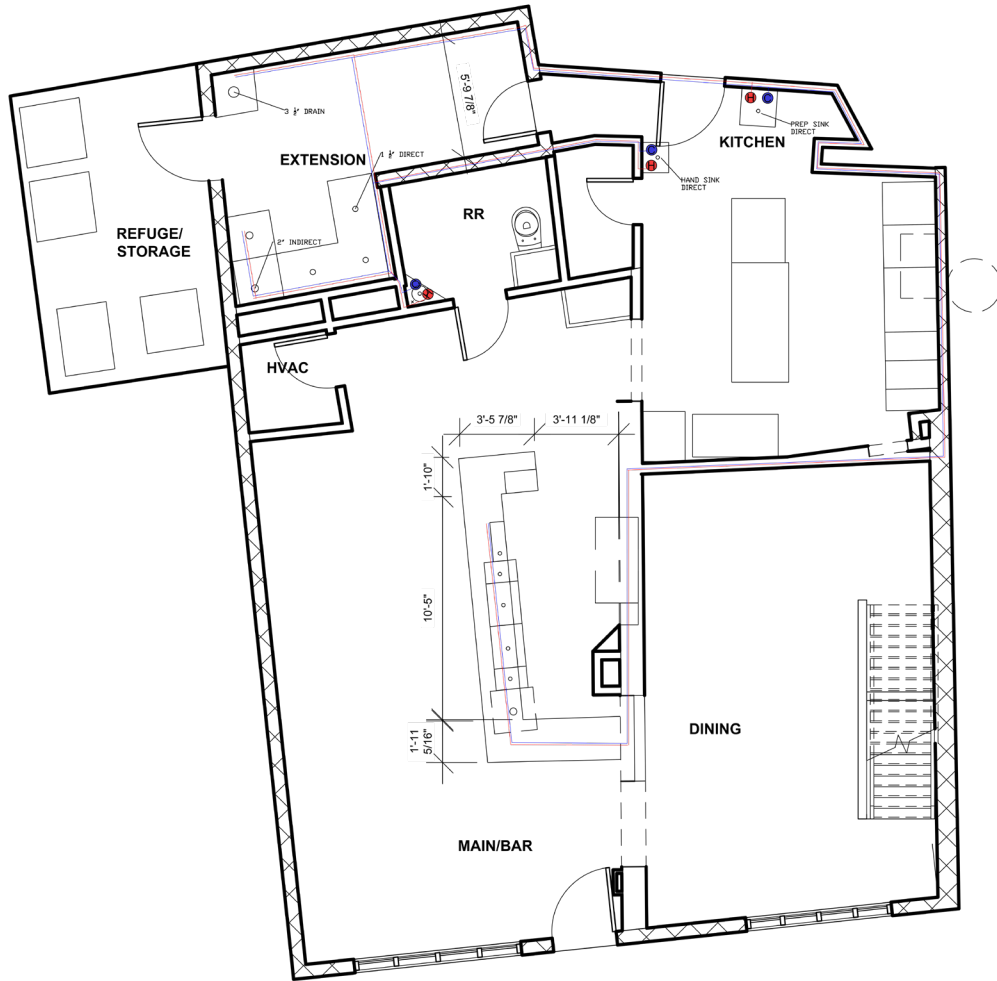

Basement Plumbing Plan [\(Click to Enlarge\)](#)

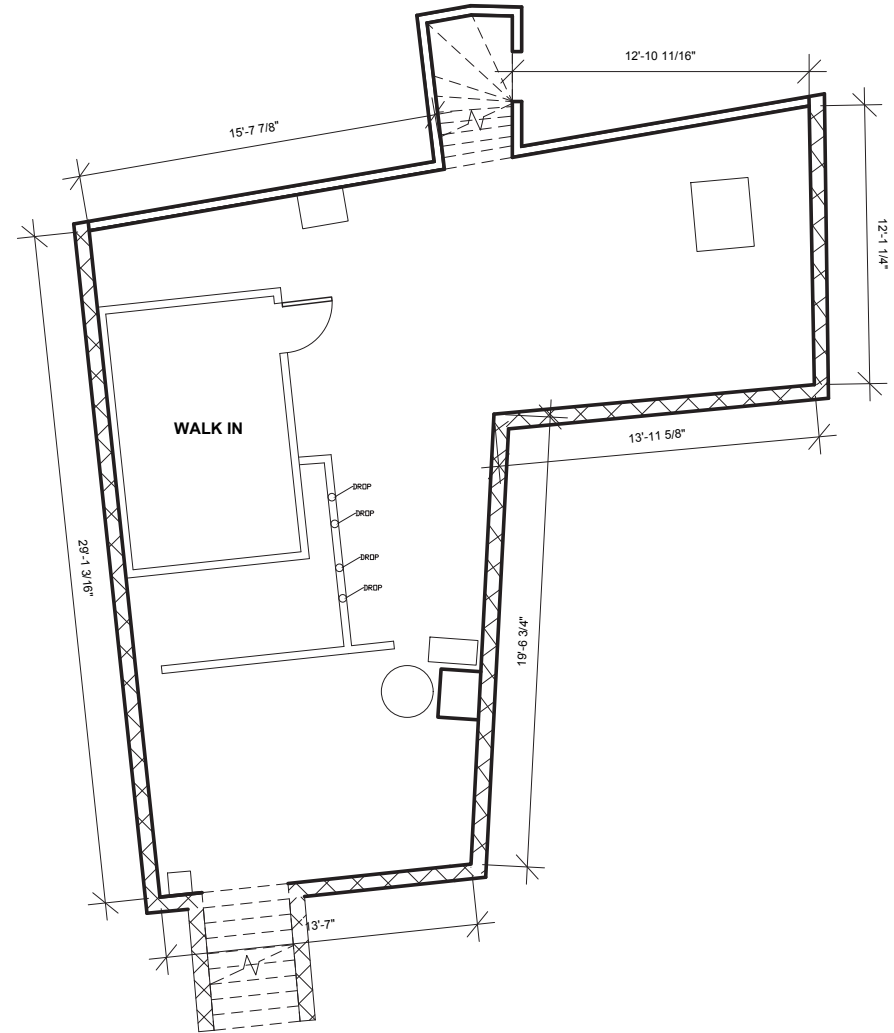

***Plans not done by Architect*

KEN MALLIN 215.803.3200 ■ kmallin@mpnrealty.com

NADIA BILYNSKY 267.441.0601 ■ nbilynsky@mpnrealty.com

3749-51 MIDVALE AVE

East Falls, Philadelphia 19129

First Floor Equipment Plan [\(Click to Enlarge\)](#)

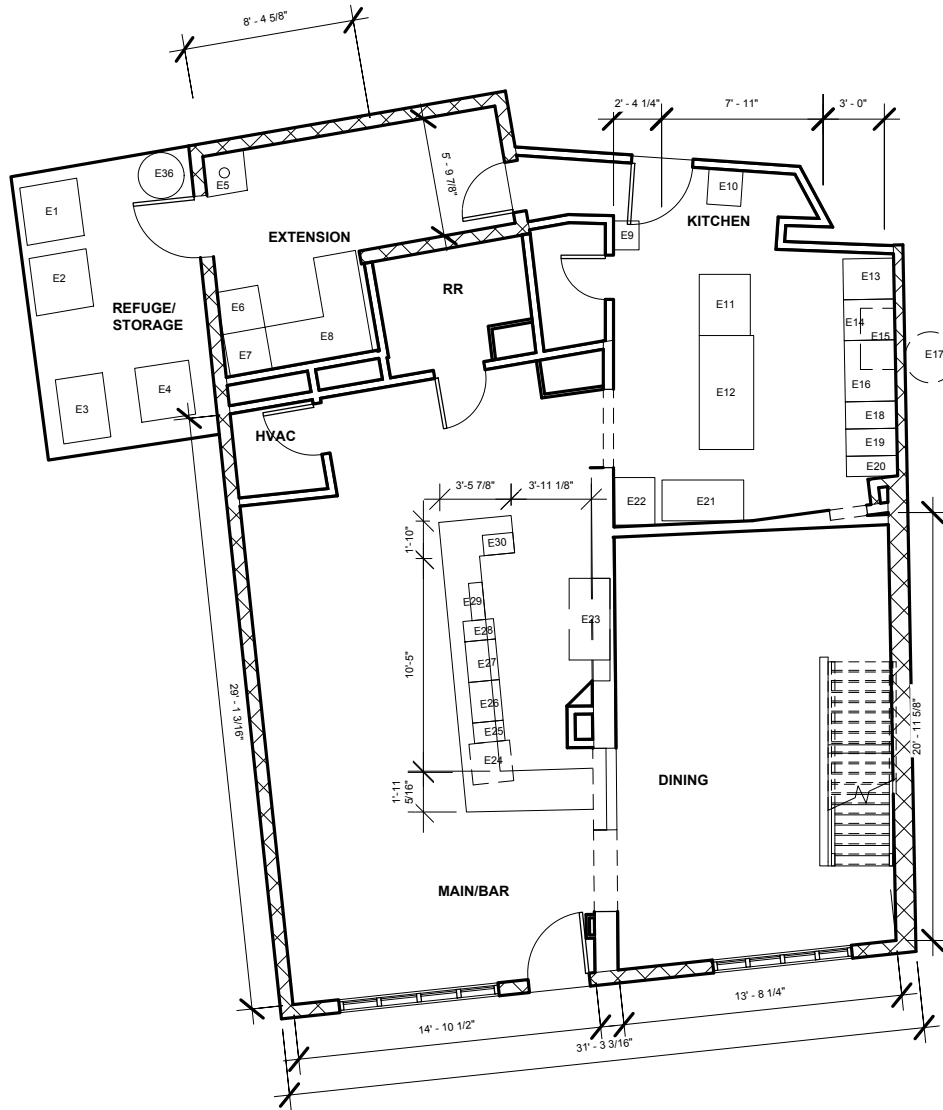

Basement Equipment Plan [\(Click to Enlarge\)](#)

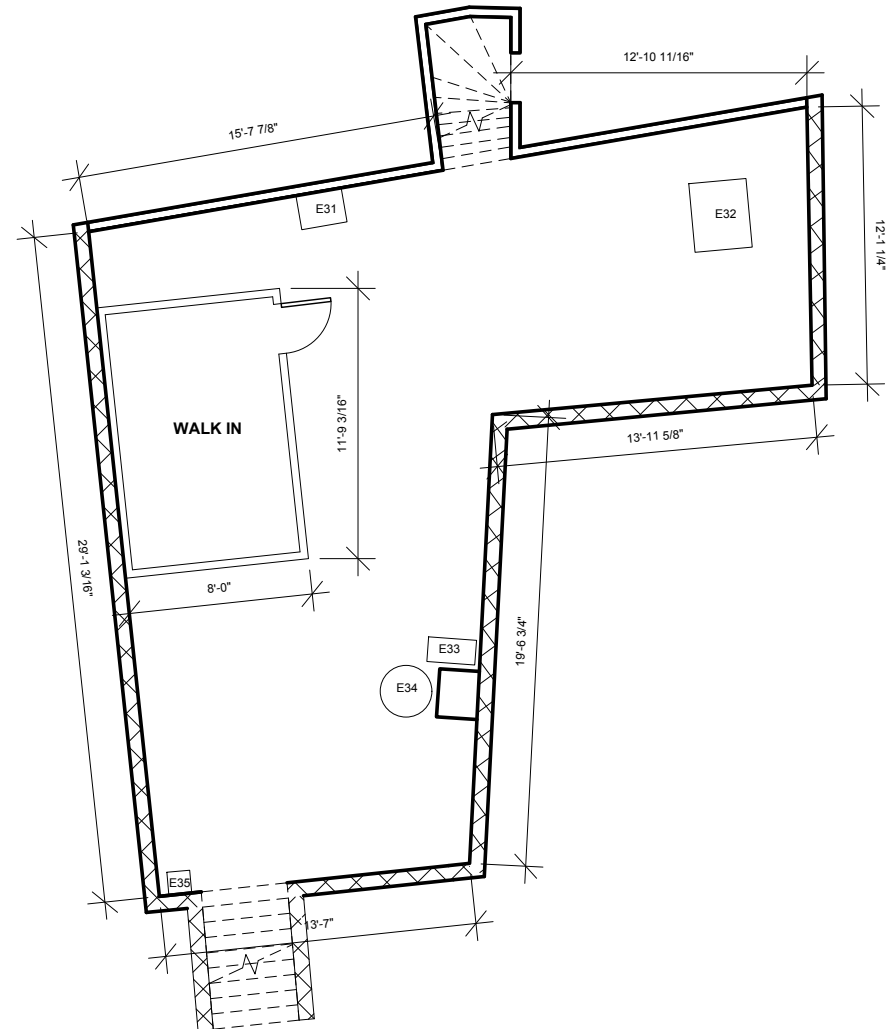

***Plans not done by Architect*

KEN MALLIN 215.803.3200 ■ kmallin@mpnrealty.com

NADIA BILYNSKY 267.441.0601 ■ nbilynsky@mpnrealty.com

3749-51 MIDVALE AVE

East Falls, Philadelphia 19129

Electrical & Lighting Plan [\(Click to Enlarge\)](#)

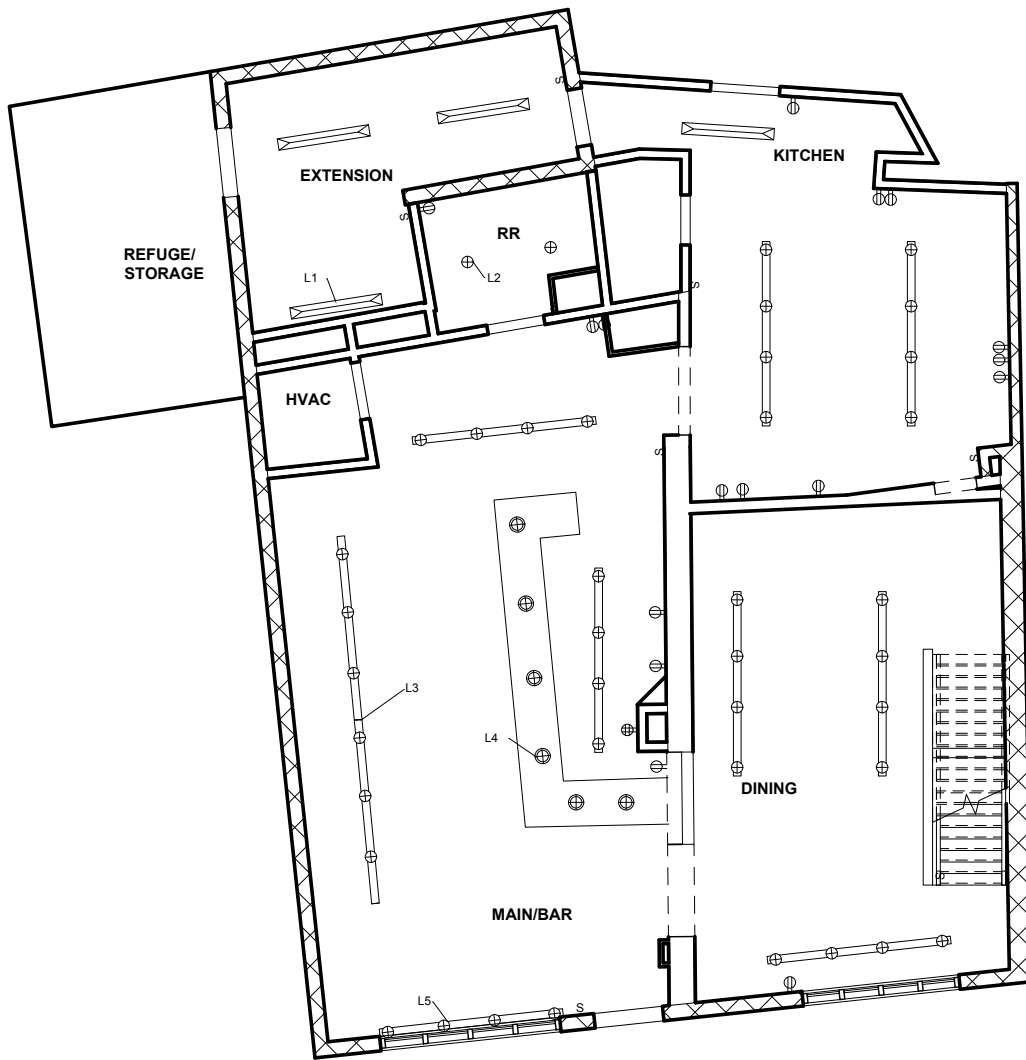

Restroom Floor Plan [\(Click to Enlarge\)](#)

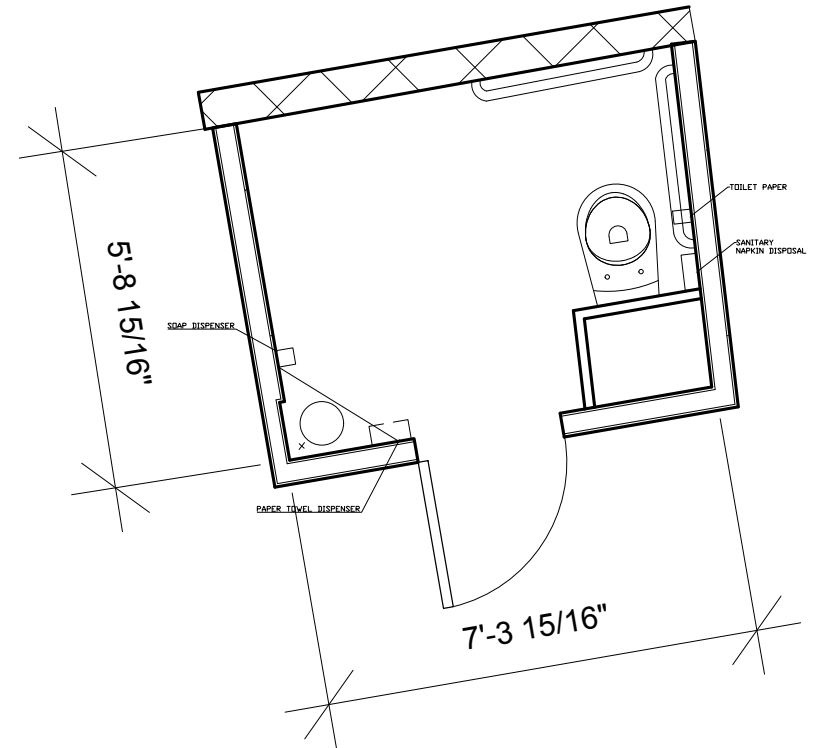

***Plans not done by Architect*

KEN MALLIN 215.803.3200 ■ kmallin@mpnrealty.com

NADIA BILYNSKY 267.441.0601 ■ nbilynsky@mpnrealty.com

3749-51 MIDVALE AVE East Falls, Philadelphia 19129

Zoning

CMX COMMERCIAL MIXED-USE

Table 14-701-3: Dimensional Standards for Commercial Districts



Max. Occupied Area	Intermediate 75%; Corner 80%
Min. Front Yard Depth	[4]
Min. Side Yard Width	5 ft. if used
Min. Rear Yard Depth	The greater of 9 ft. or 10% of lot depth
Max. Height	55 ft.*
Min. Cornice Height	25 ft.

Table Notes:

[4] In the CMX-2.5 district, buildings must be built to the lot line of any primary frontage, as designated in § 14-701(1)(d)(.4) (Primary Frontage)

* Zoning Bonus Summary		CMX-2.5	
		Additional Height	Housing Unit Bonus
Mixed Income Housing (§14-702(7))	Moderate Income	7 ft.	25% increase in units permitted
	Low Income	7 ft.	50% increase in units permitted
Green Roof (§14-702(16))		n/a	25% increase in units permitted

CMX-2.5

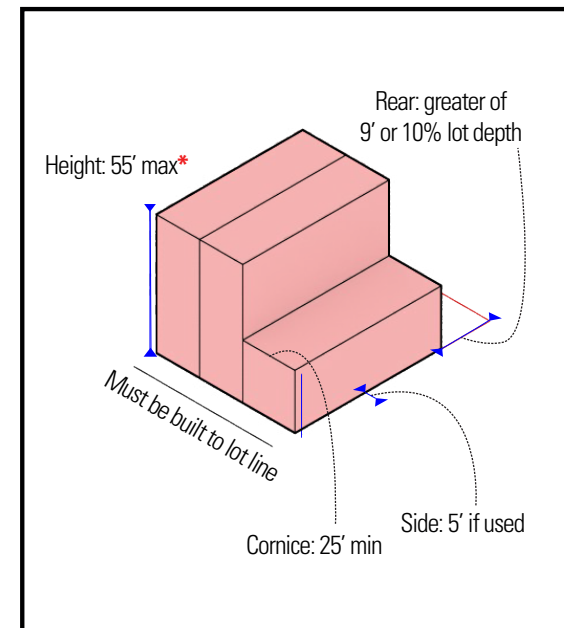

3749-51 MIDVALE AVE

East Falls, Philadelphia 19129

Retail Map



3749-51 MIDVALE AVE

East Falls, Philadelphia 19129

About the Neighborhood: East Falls

Welcome to East Falls, a vibrant neighborhood in Philadelphia, Pennsylvania, where city living harmonizes with natural beauty. With a population of 11,023 residents, East Falls attracts young professionals who appreciate its lively ambiance and progressive atmosphere.

Here, you'll find a diverse range of amenities, including trendy bars and cozy coffee shops, all contributing to the neighborhood's bustling energy. Set against the picturesque Schuylkill River, East Falls boasts a tranquil setting enhanced by its historic architecture.

Once home to the famous "Falls of the Schuylkill," East Falls now thrives as an entertainment hub along the riverfront. Nearby Germantown, East Fairmount Park, and Wissahickon Valley Park offer ample opportunities for outdoor recreation.

Conveniently located just 7 minutes from Center City via Kelly Drive, East Falls offers the perfect blend of urban convenience and small-town charm. Come and experience the essence of Philadelphia living in East Falls.

