



**MIDTOWN
OFFICE CENTER**

5720 LYNDON B JOHNSON FWY



Building
FEATURES

Conference Facilities

Tenant Lounge

Covered Parking

Signage Opportunities

Monitored Security

Building Engineer

24 Hour Access



Tenant
LOUNGE



Conference
ROOM



Main
LOBBY

Local FAVORITES



RESTAURANTS

- Grande Lux Cafe
- The Oceanaire Seafood Room
- Mi Cocina
- Crockett's Restaurant and Bar
- Maple Leaf Diner
- Original ChopShop
- The Mercury
- Liberty Burger



COFFEE

- Starbucks
- Dunkin'
- The Market Local Comfort Cafe
- The Nest Cafe



HOTELS

- Hilton Dallas Lincoln Centre
- The Westin
- AC Hotel by Marriott
- La Meridien Dallas
- Sheraton Dallas Hotel



RETAIL | ENTERTAINMENT

- Galleria Mall
- Northwood Club
- Target

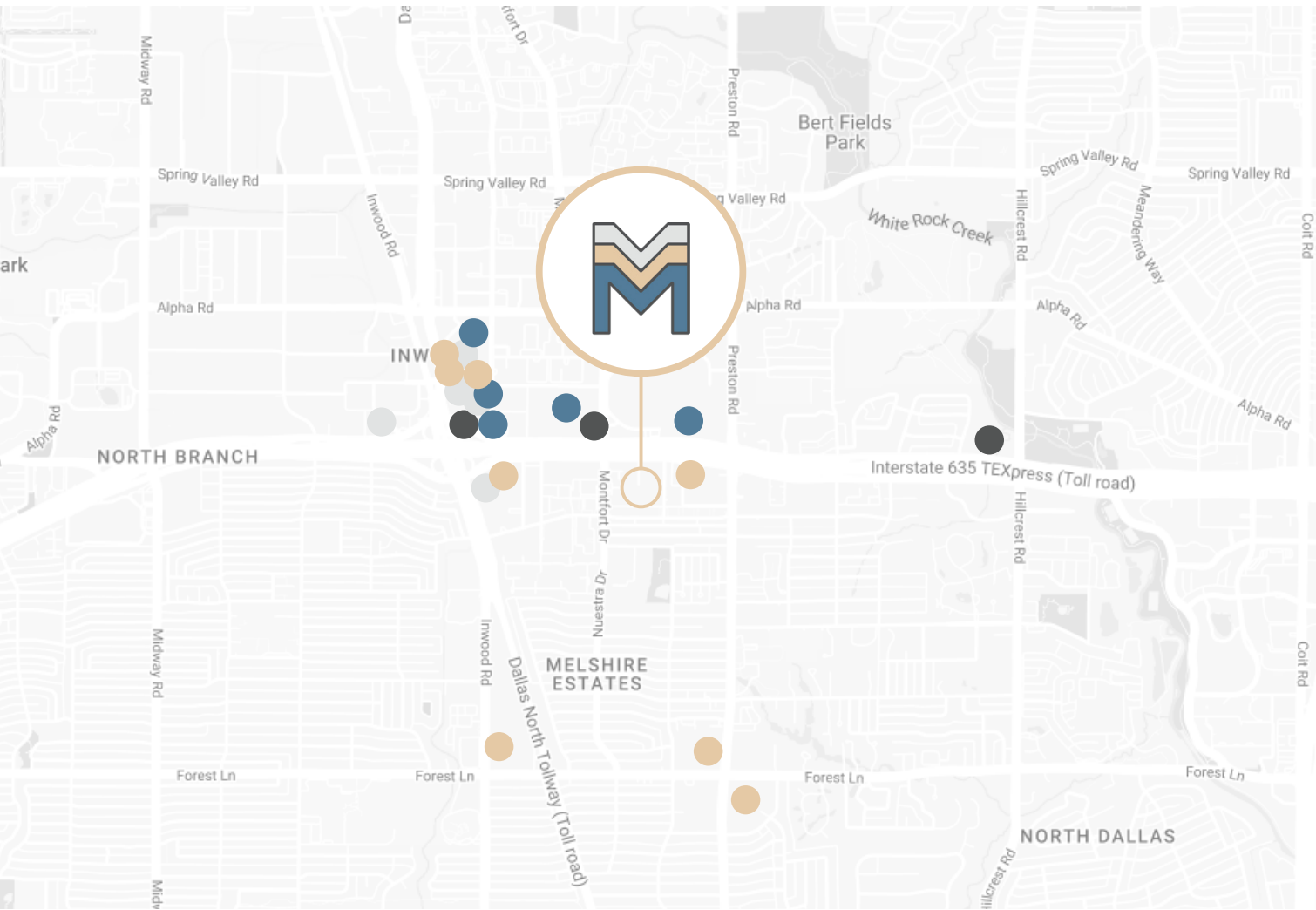



DESTINATIONS



1 MILE



16 MILES



9 MILES



11 MILES

Available SUITES



SUITE 660 | 2,661 SF
SUITE 625 | 3,317 SF
SUITE 605 | 2,373 SF

SUITE 490 | 2,748 SF
SUITE 455 | 425 SF
SUITE 410 | 3,178 SF

SUITE 350 | 9,757 SF

SUITE 200 | 22,708 SF

SUITE 100 | 3,174 SF

6

STORIES

4

ELEVATORS

3/1000

PARKING

128,790

TOTAL BUILDING SIZE

23,000

TYPICAL FLOOR SIZE

22,708

LARGEST CONTIGUOUS SF

SUITE 100

FIRST FLOOR | 3,174 SF

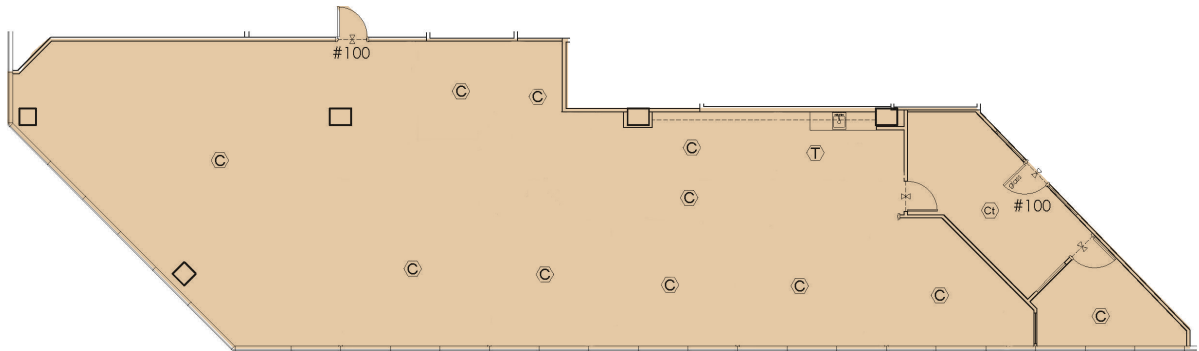

SUITE 100

SUITE 200

SECOND FLOOR | 22,708 SF



SUITE 200

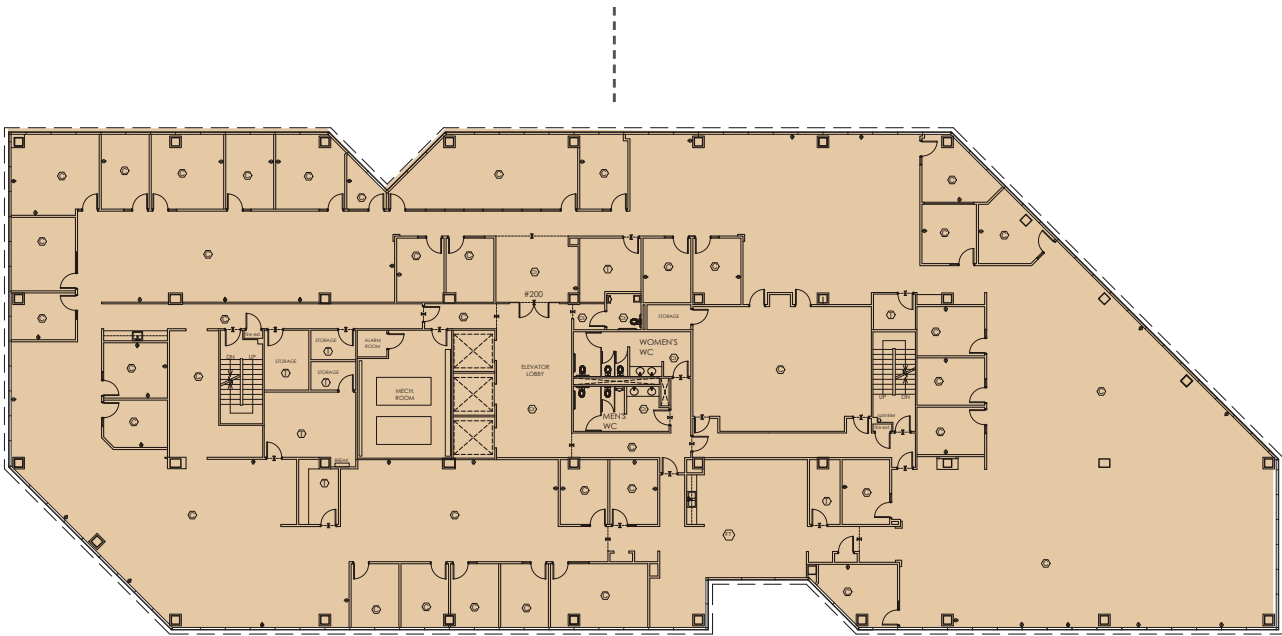

SUITE 350

THIRD FLOOR | 9,757 SF

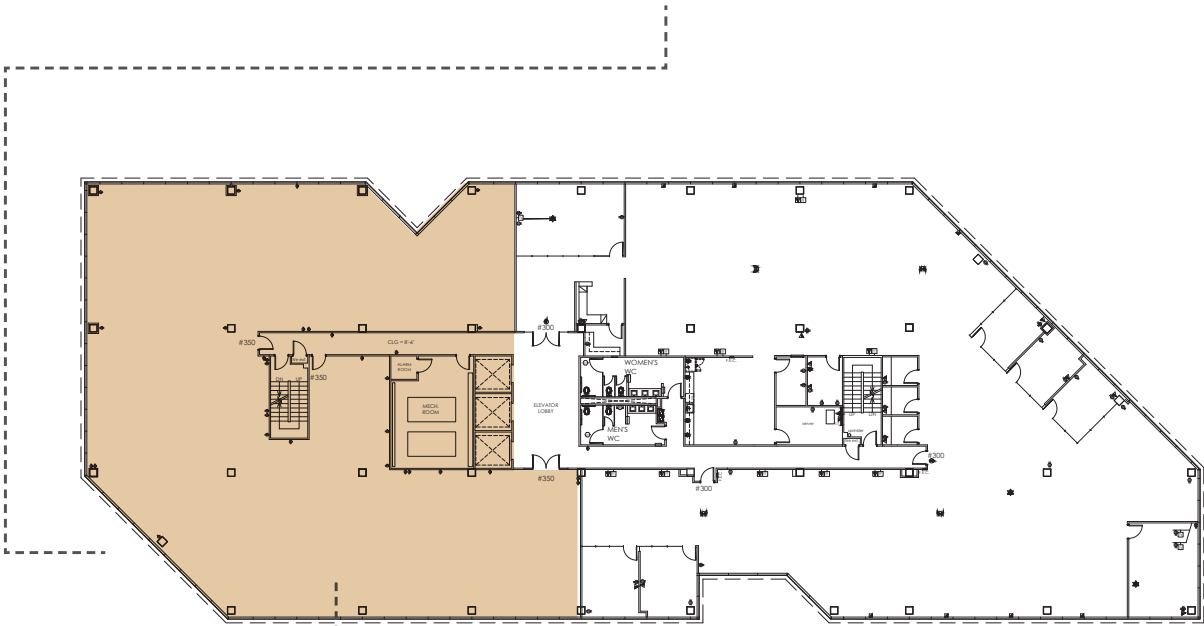
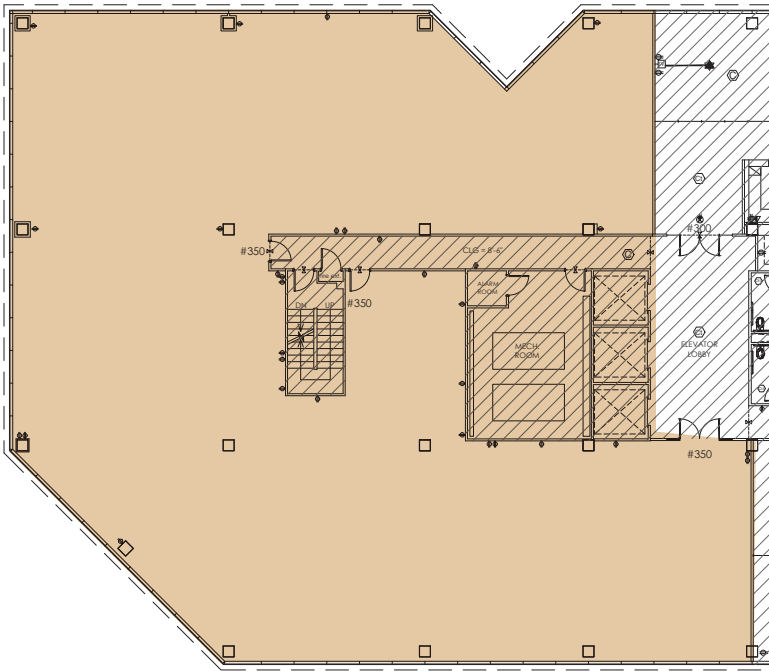

SUITE 350

SUITE 410

FOURTH FLOOR | 3,178 SF

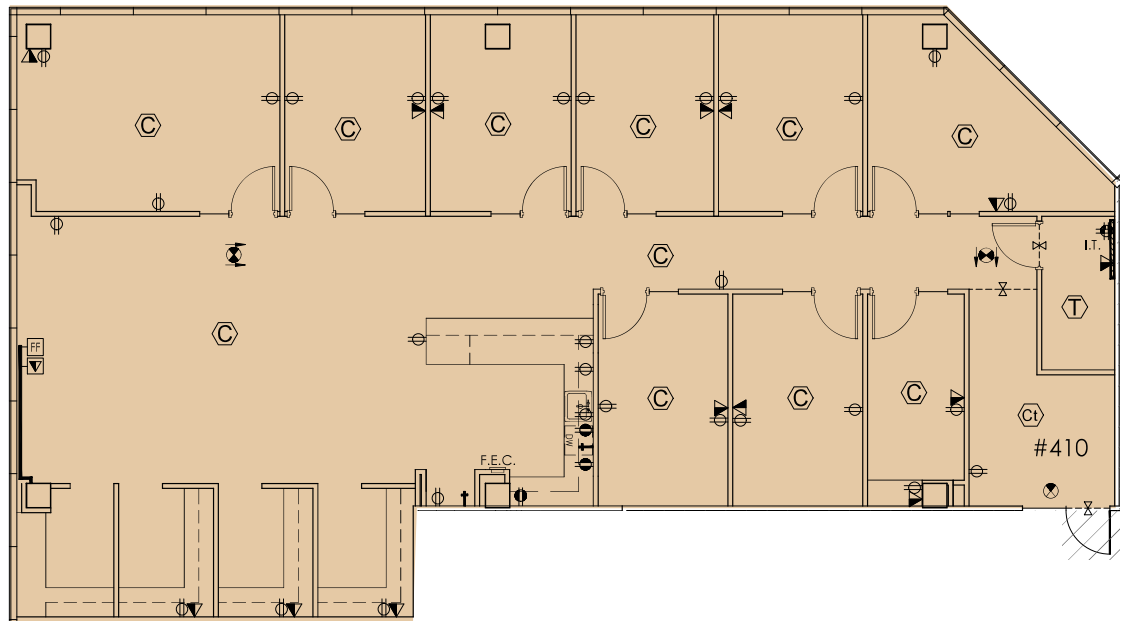

SUITE 410

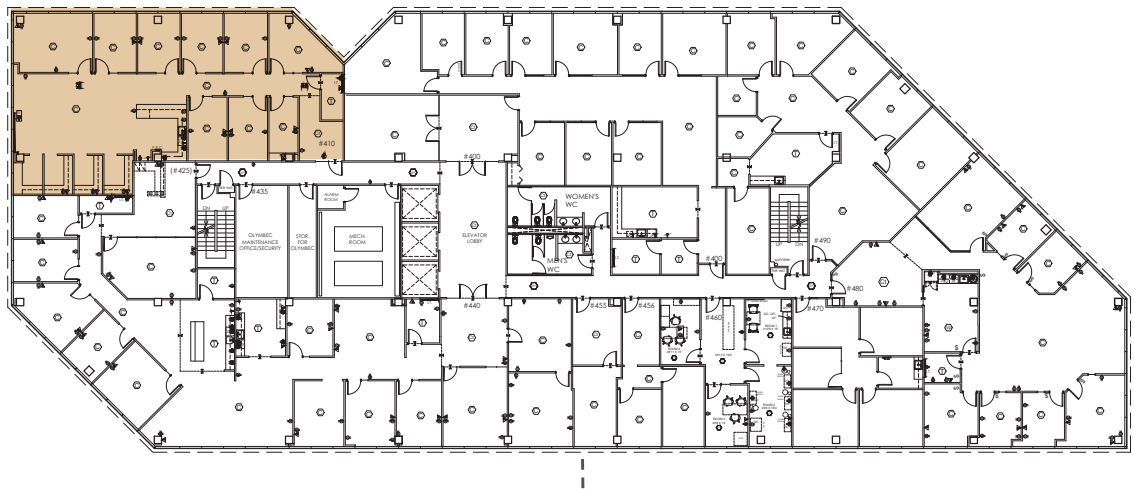

SUITE 455

FOURTH FLOOR | 425 SF

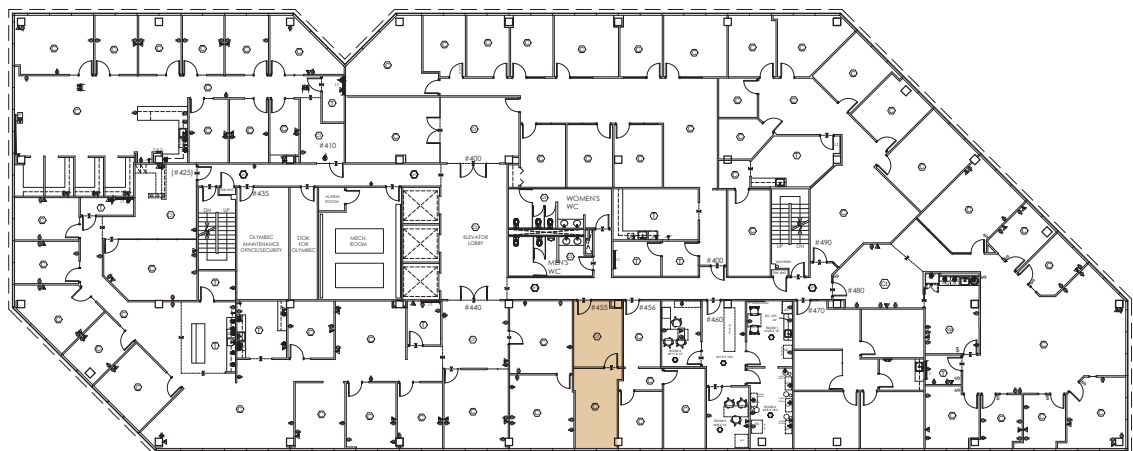
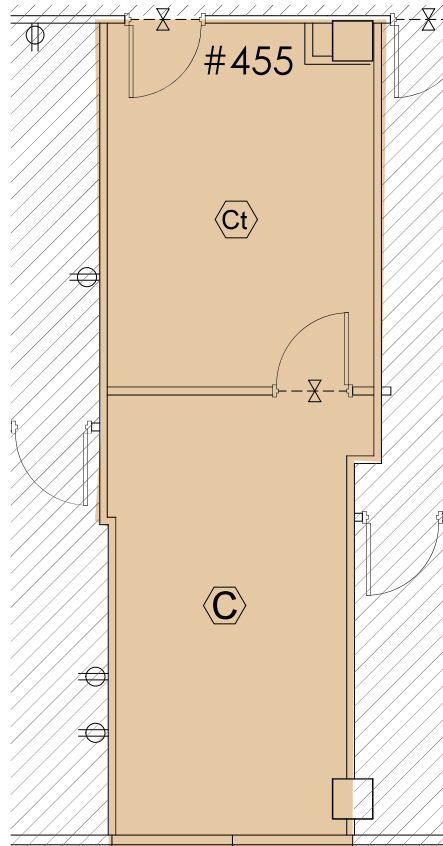

SUITE 455

SUITE 490

FOURTH FLOOR | 2,748 SF

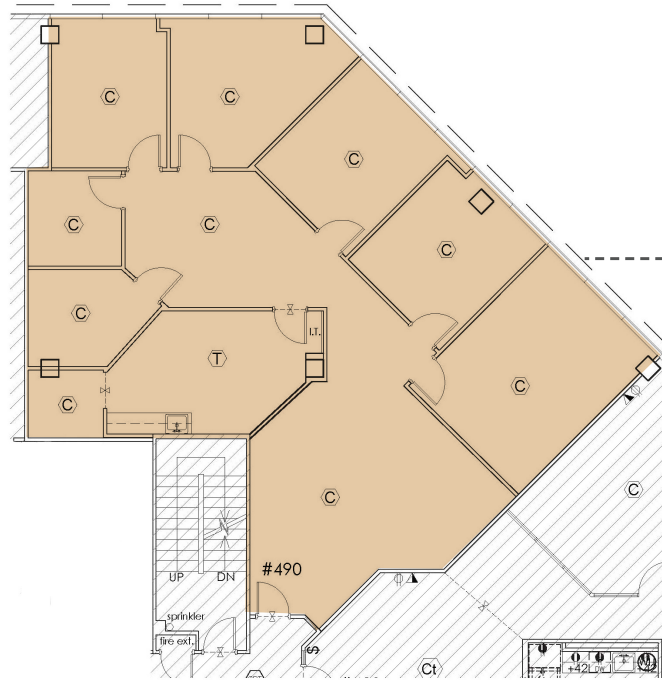

SUITE 490

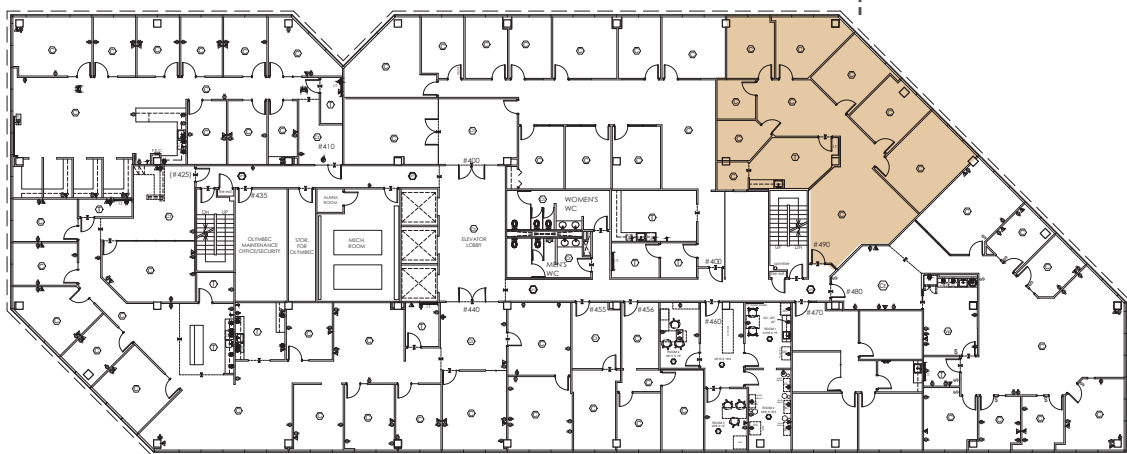

SUITE 605

SIXTH FLOOR | 2,373

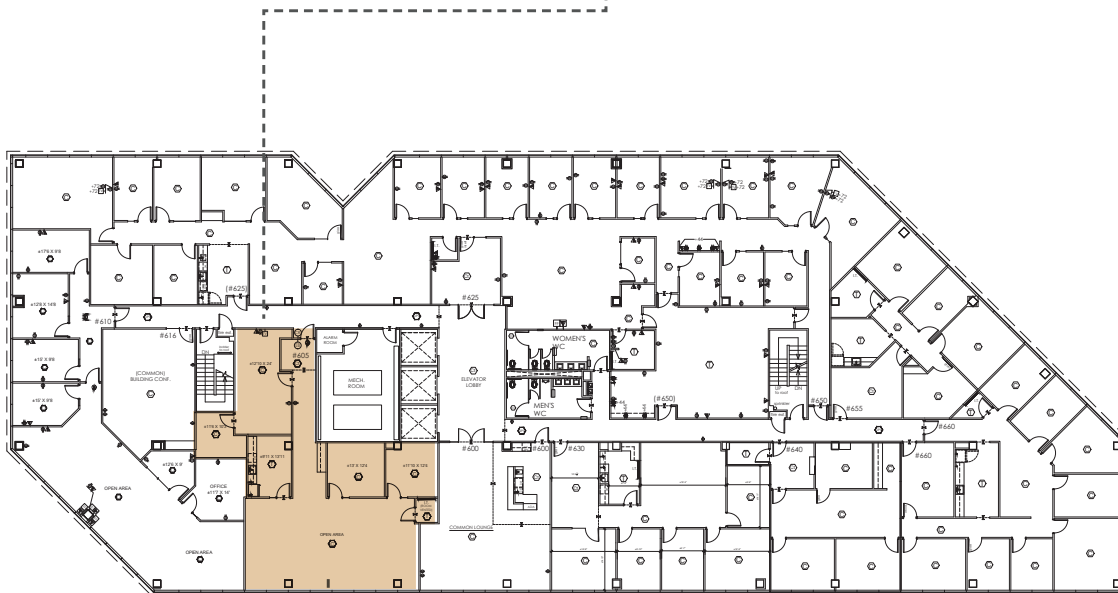
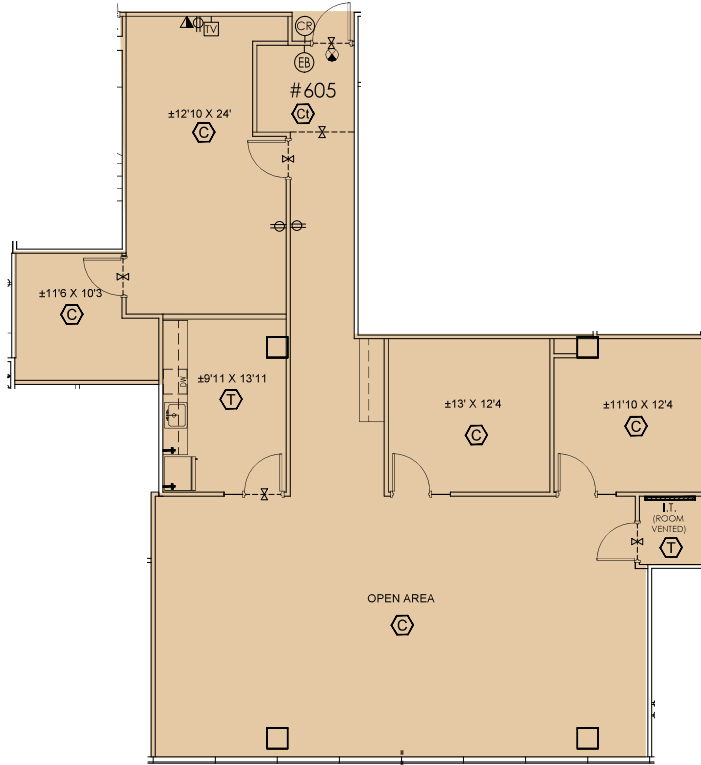

SUITE 605

SUITE 625

SIXTH FLOOR | 3,317 SF

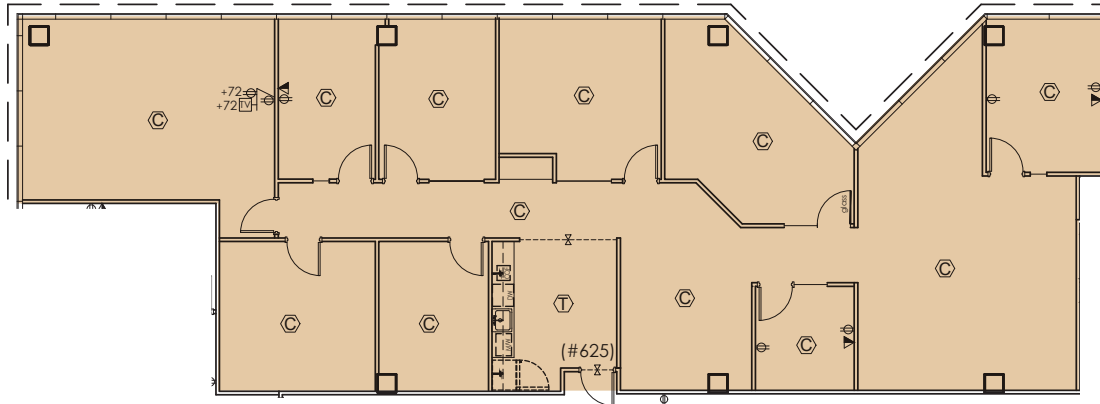

SUITE 625

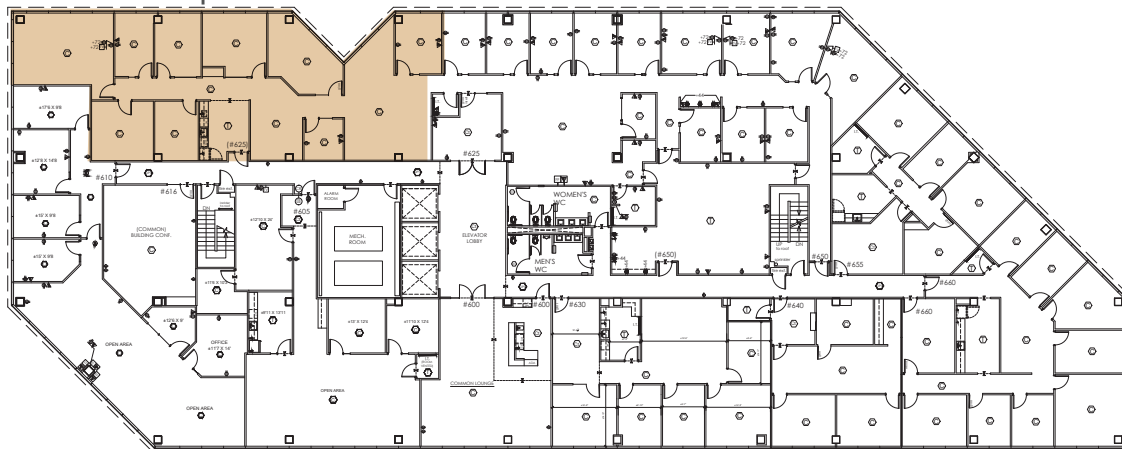

SUITE 660

SIXTH FLOOR | 2,661 SF

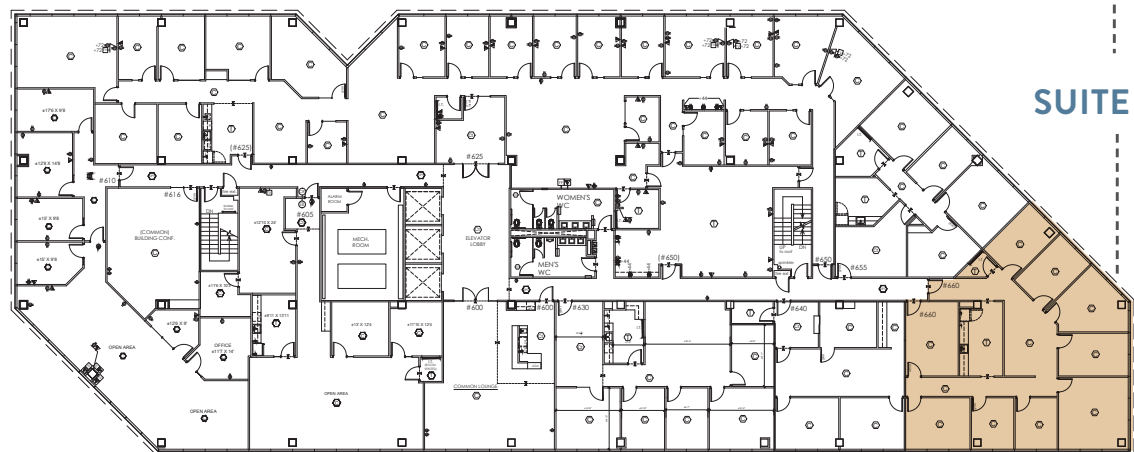
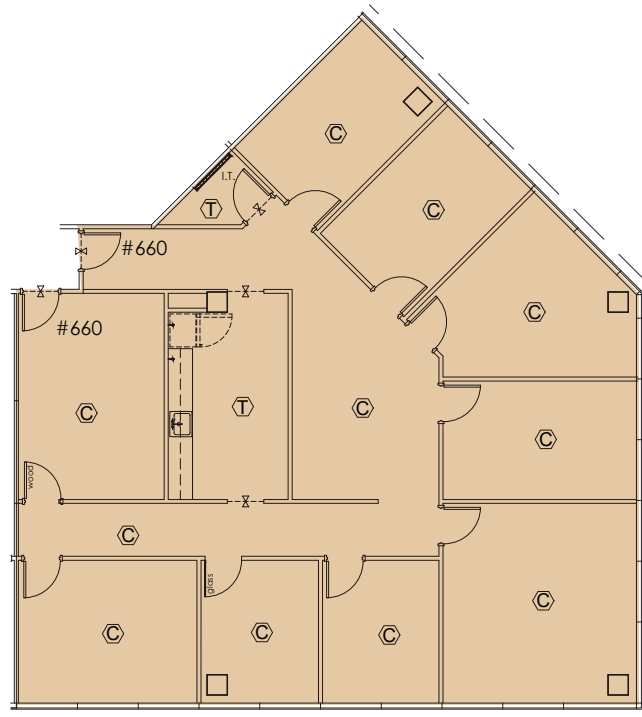

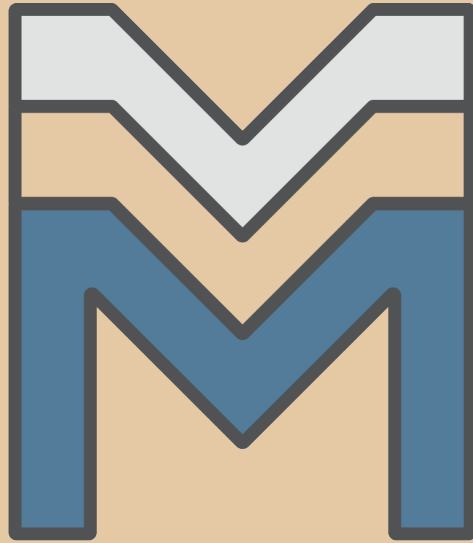

MIDTOWN OFFICE CENTER

5720 LYNDON B JOHNSON FWY



4851 LBJ Fwy, 10th Floor | Dallas, TX 75244
214.256.7100 | NAIRL.COM

JAMES DAVIS

Executive Vice President
jdavis@nairl.com
214.256.7103

SAMANTHA SANCHEZ

Transaction Coordinator
ssanchez@nairl.com
214.256.7179