



M E R I D I A N

147 S. CHERRY STREET, SUITE 200 | WINSTON-SALEM, NC 27101 | P 336.722.1986 | F 336.723.3173 | MERIDIANREALTY.COM

Versatile Investment Property

1489 N. Main Street

Mocksville, NC 27028



This fully leased commercial property is an attractive investment opportunity located with frontage on N. Main Street (Highway 158) in Mocksville, NC. This versatile property features a 10,090± sf front building that has office and shop space on the main level with a combination of basement office and storage space. Behind the front building is a 1,350± sf metal garage built in 2021. The buildings are on a 0.54± acre site zoned Highway Commercial (HC), ideal for a variety of potential uses. Financials are available upon request.

For more information:

Tiffany J. Secoges, CCIM

Tiffany.s@meridianrealty.com

336.480.2094

FOR SALE: \$430,000

WWW.MERIDIANREALTY.COM

INVESTMENT HIGHLIGHTS

Fully leased to 4 tenants:

Upper level - Tenant 1

Lower level - Tenant 2 & 3

Garage - Tenant 4

Flexible lease terms, Ideal for investor or owner/user

Cap rate: 9.5%

PROPERTY DETAILS

10,090± SF front building

1,350± SF metal garage

Site: 0.54± AC

Zoning: Highway Commercial (HC)

Parking: 7 front parking spaces with additional parking available in rear

Garage

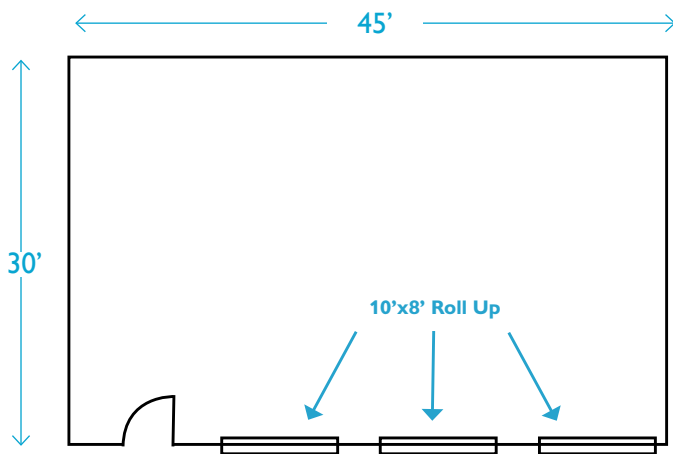

Upper Level

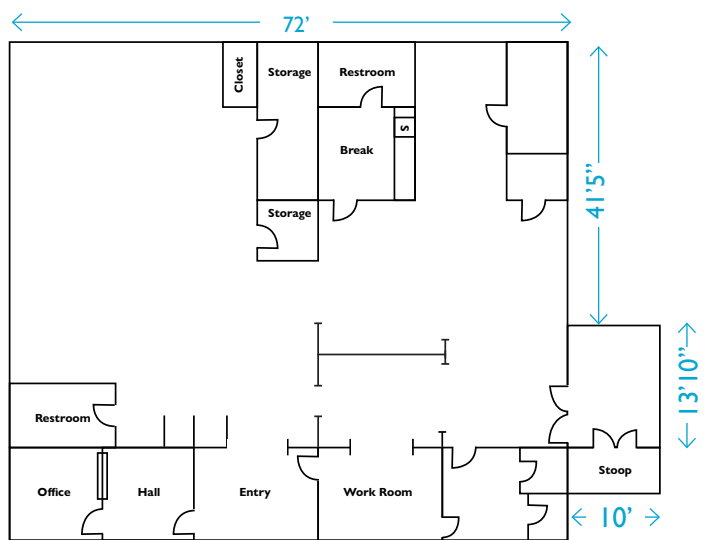

Aerial



Demographics

	1mi.	3mi.
Population	1,873	9,420
Growth '24 - '29	↑ 9.72%	↑ 9.20%
Households	771	3,695
Growth '24 - '29	↑ 9.47%	↑ 8.90%
Avg. Household Income	\$42,788	\$53,066
Daytime Employees	457	6,189

1489 N. Main Street | Mocksville, NC 27028

Interior Photos



Exterior Photos



1489 N. Main Street | Mocksville, NC 27028

AERIAL



Property Details

- Fully leased (four tenants)
- 10,090± sf front building
- 1,350± sf garage
- High visibility location
- Zoned Highway Commercial (HC)
- Sale Price: \$430,000.00

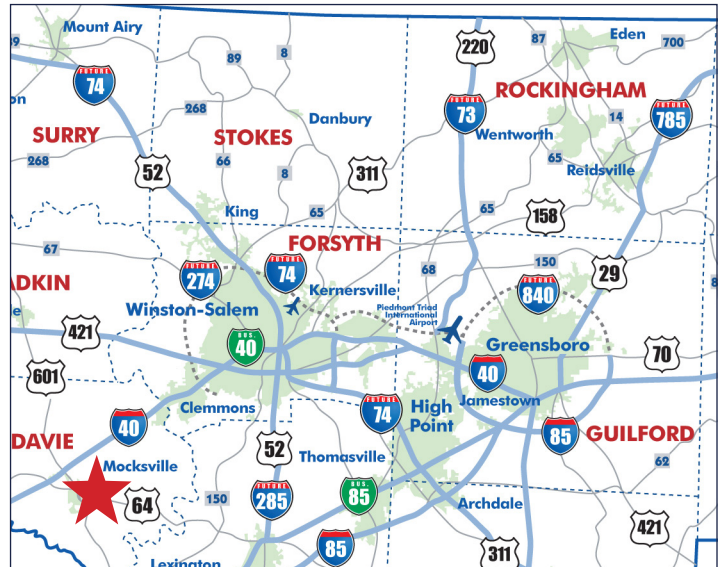

No warranty or representation (express or implied) is made as to the accuracy or completeness of the information set forth herein. All information is submitted subject to errors, omissions, change of price, prior lease or sale, and withdrawal without notice. All marketing material produced by the Meridian Realty Group is proprietary. Any reproduction is expressly prohibited.



THE MERIDIAN REALTY GROUP | 147 S. CHERRY STREET, SUITE 200 | WINSTON-SALEM, NC 27101

P 336.722.1986 | F 336.723.3173

WWW.MERIDIANREALTY.COM