

BEING 10.00 ACRES, OUT OF THE RAFAEL GARZA SURVEY NO. 98, COMAL COUNTY, TEXAS, BEING ALL OF A CALLED 10.01 ACRE TRACT RECORDED IN DOC. NO. 201206024231, OFFICIAL PUBLIC RECORDS, COMAL COUNTY, TEXAS.

REFERENCE TRINITY TITLE INSURANCE COMPANY COMMITMENT, GF #443NB, EFFECTIVE DATE 08/28/12.

INGRESS AND EGRESS EASEMENT RECORDED IN VOLUME 205, PAGE 479, DEED RECORDS, COMAL COUNTY, TEXAS.

GAS PIPE LINE EASEMENT TO UNITED GAS PIPE LINE COMPANY RECORDED IN VOLUME 113, PAGE 481, DEED RECORDS, COMAL COUNTY, TEXAS.

NO PORTION OF THIS PROPERTY LIES WITHIN THE 100-YEAR FLOODPLAIN.

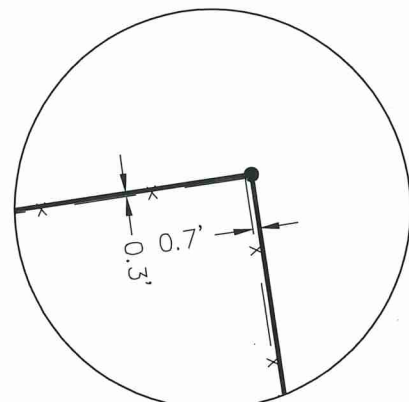
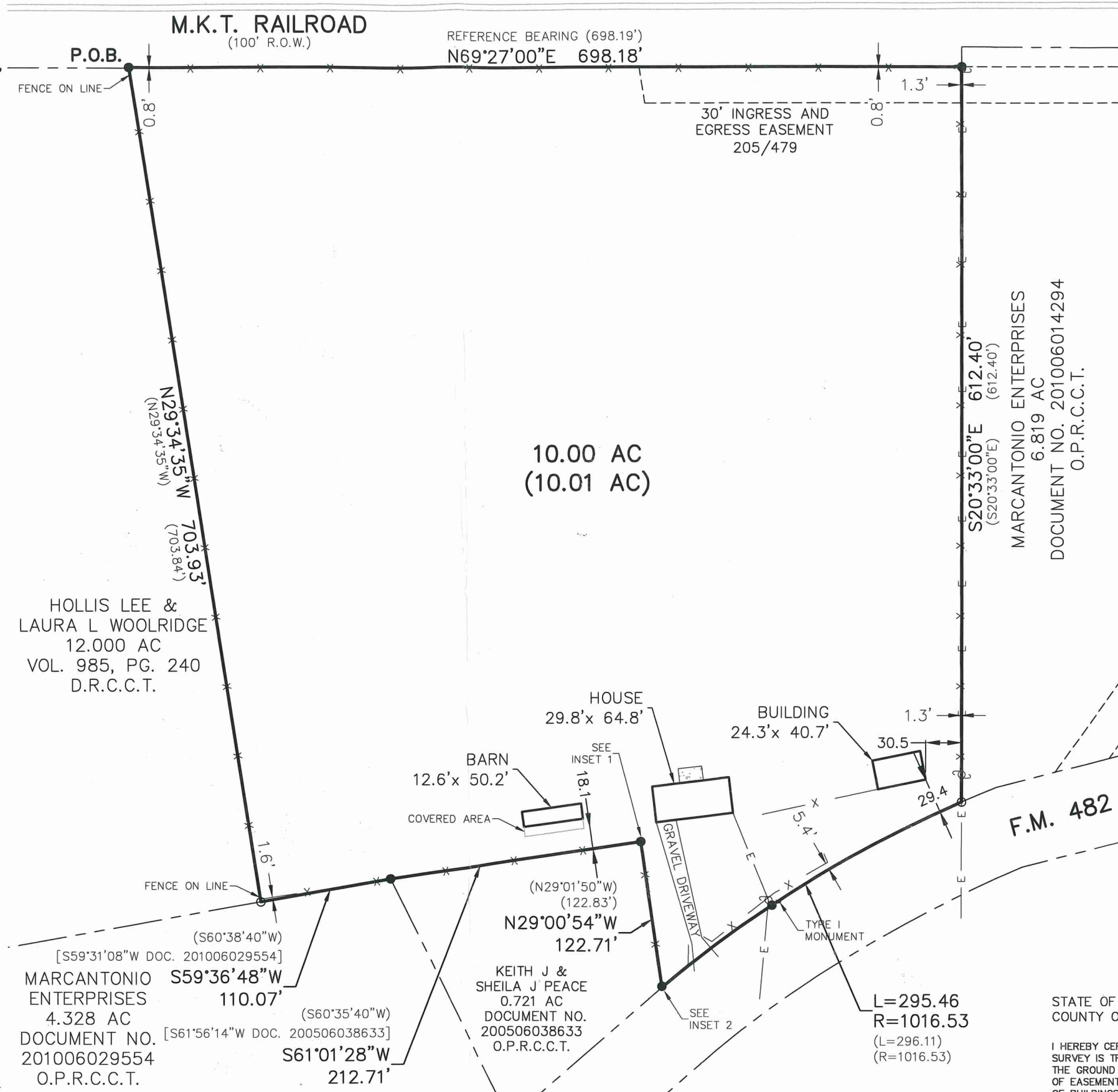

INSET 1

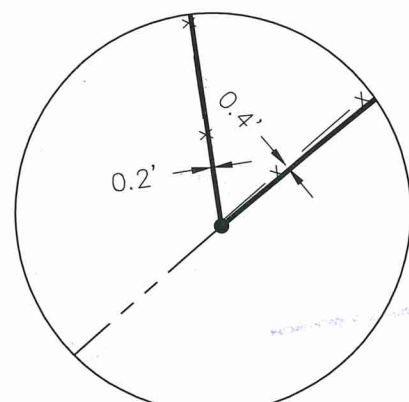

INSET 2

HOLLIS LEE & LAURA L WOOLRIDGE
12.000 AC
VOL. 985, PG. 240
D.R.C.C.T.

MARCANTONIO ENTERPRISES
4.328 AC
DOCUMENT NO. 201006029554
O.P.R.C.C.T.

KEITH J & SHEILA J PEACE
0.721 AC
DOCUMENT NO. 200506038633
O.P.R.C.C.T.

10.00 AC
(10.01 AC)

F.M. 482

MARCANTONIO ENTERPRISES
6.819 AC
DOCUMENT NO. 201006014294
O.P.R.C.C.T.

- LEGEND:**
- = SET 1/2" IRON PIN W/ A PLASTIC CAP STAMPED "HMT" UNLESS OTHERWISE NOTED
 - = FND 1/2" IRON PIN UNLESS OTHERWISE NOTED
 - R.O.W. = RIGHT-OF-WAY
 - () = DEED CALLS
 - ⊕ = POWER POLE
 - E — = OVERHEAD ELECTRIC
 - X — = FENCE
 - P.O.B. = POINT OF BEGINNING
 - D.R.C.C.T. = DEED RECORDS OF COMAL COUNTY, TEXAS
 - O.P.R.C.C.T. = OFFICIAL PUBLIC RECORDS OF COMAL COUNTY, TEXAS



SCALE: 1"=100'



7410 F.M. 482
NEW BRAUNFELS, TEXAS

THIS SURVEY IS CERTIFIED TO:
TRINITY TITLE OF TEXAS, LLC, AND
JAMIE RADOVICH & DIANE KAY BALLARD

STATE OF TEXAS
COUNTY OF COMAL

I HEREBY CERTIFY TO THE BEST OF MY KNOWLEDGE AND BELIEF THAT THIS SURVEY IS TRUE AND CORRECT ACCORDING TO AN ACTUAL SURVEY MADE ON THE GROUND UNDER MY SUPERVISION AND THAT ALL OBSERVABLE EVIDENCE OF EASEMENTS ON THE GROUND ARE SHOWN AND ALL OBSERVABLE EVIDENCE OF BUILDINGS, STRUCTURES AND OTHER IMPROVEMENTS SITUATED ON THE ABOVE PREMISES ARE SHOWN

THIS 24TH DAY OF SEPTEMBER 2012
[Signature]
MARK F. CONLAN
REGISTERED PROFESSIONAL LAND SURVEYOR NO. 6342



410 N. SEGUIN AVE.
NEW BRAUNFELS,
TEXAS, 78130
WWW.HMTNB.COM
PH: (830)625-8555