

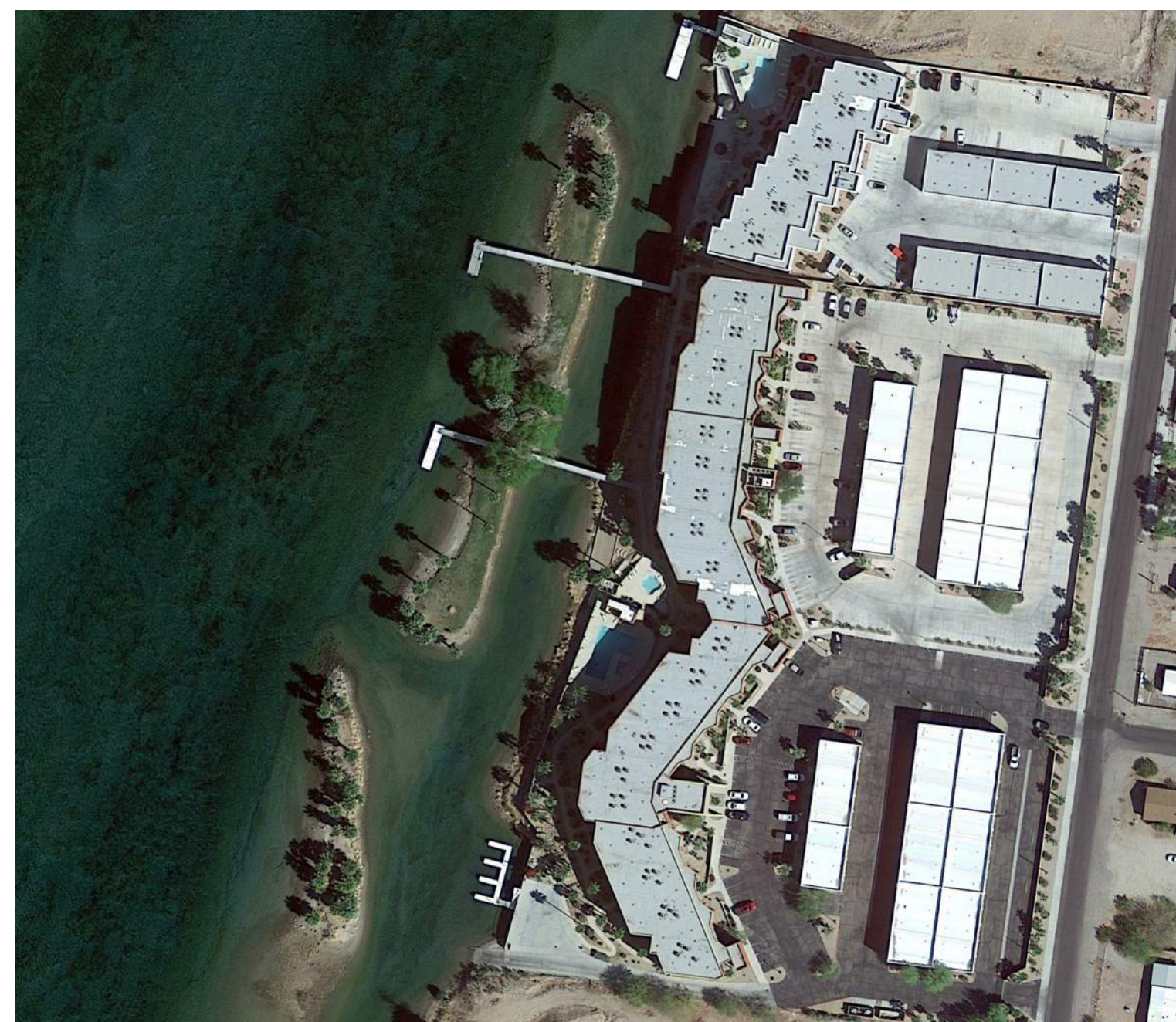

ANTHEM TRAVEL CENTER
BULLHEAD, ARIZONA

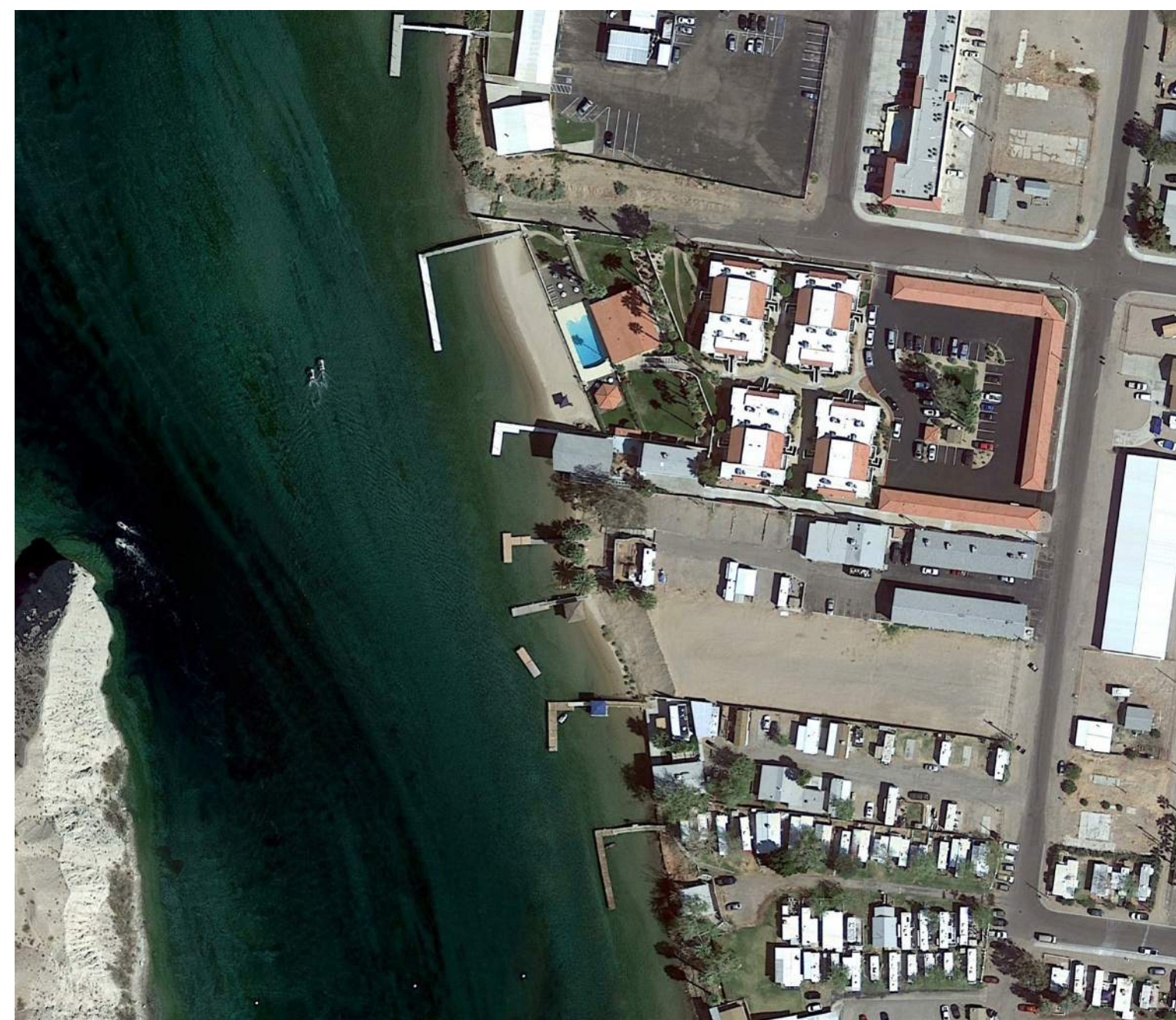

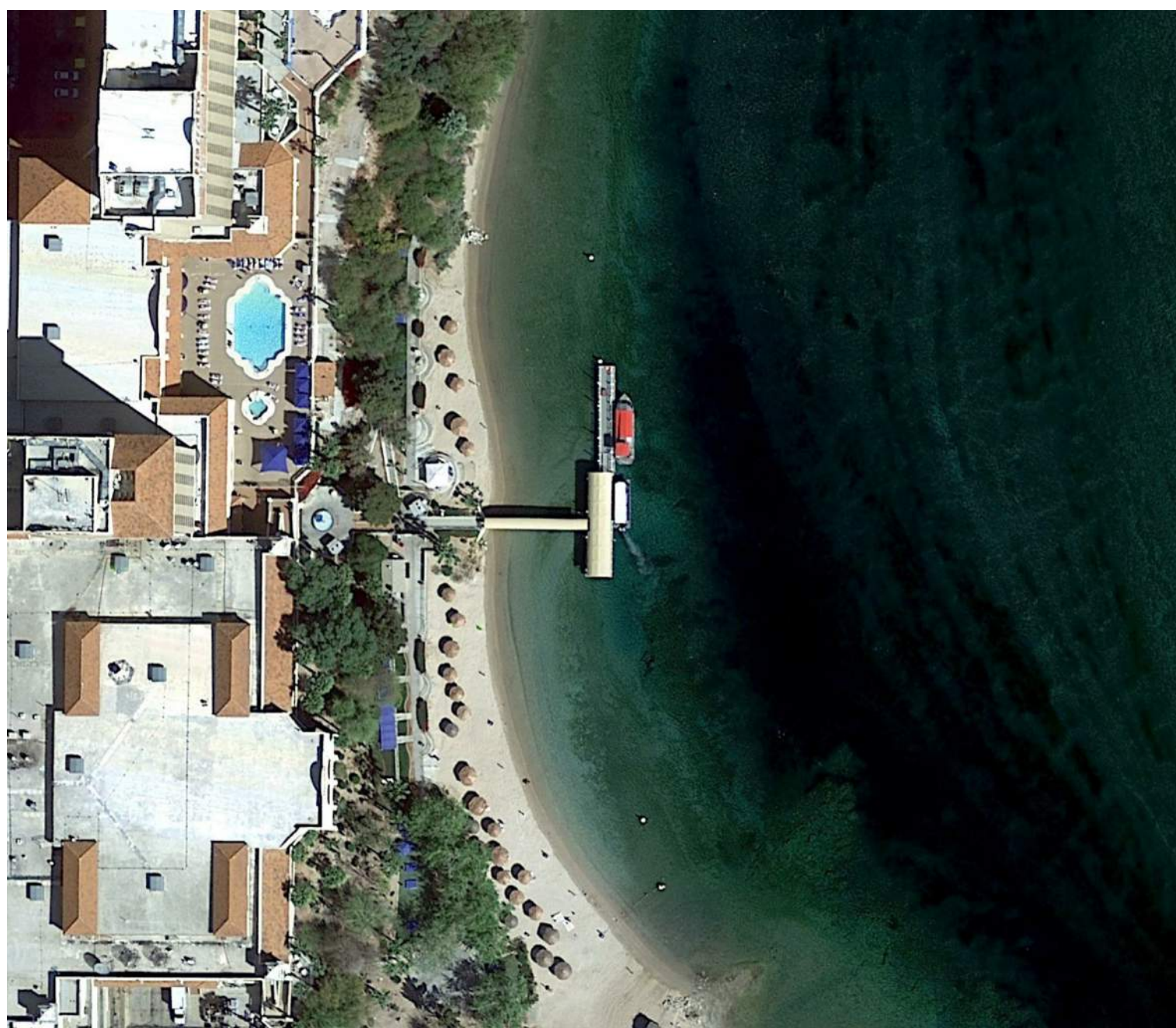

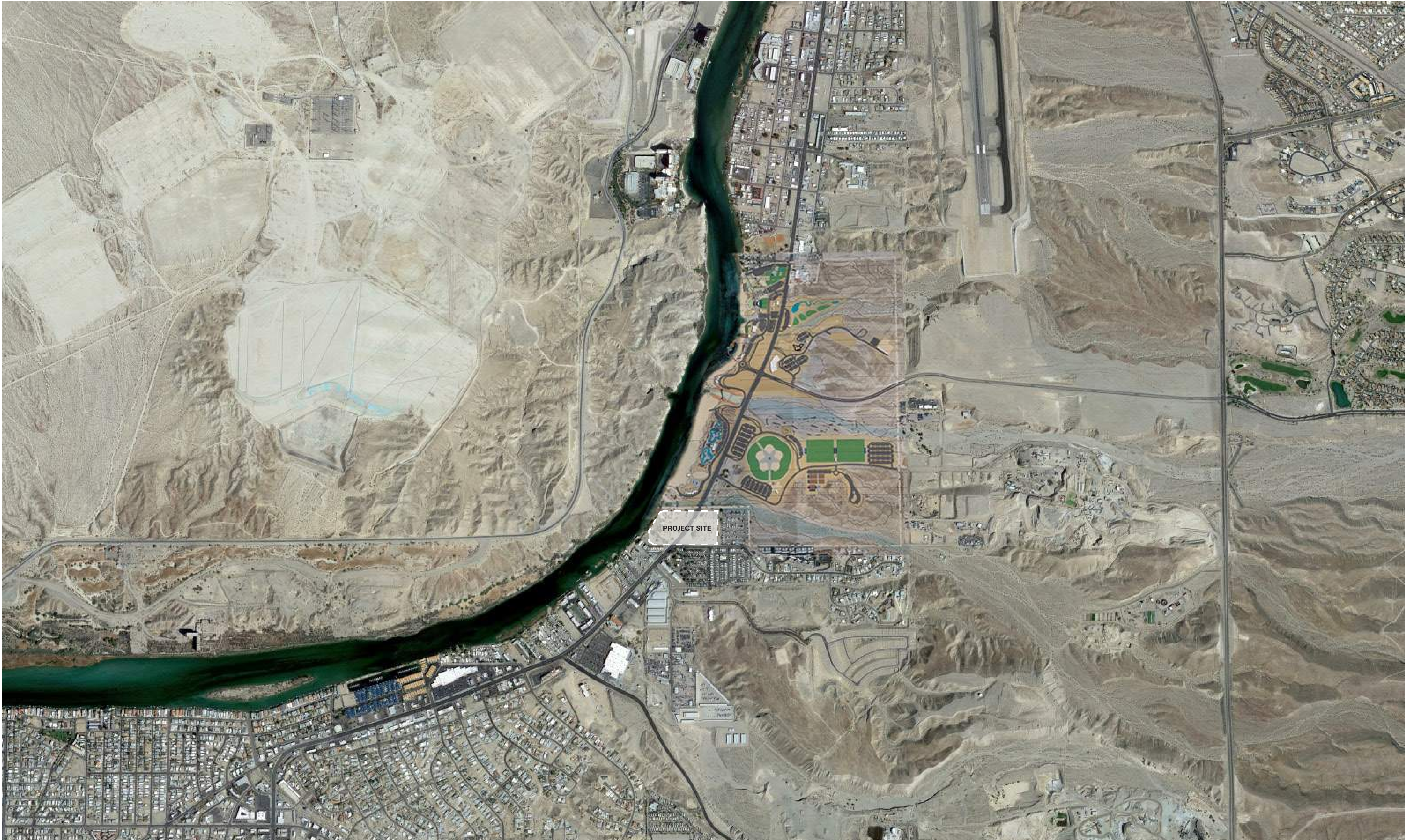

PROJECT SITE

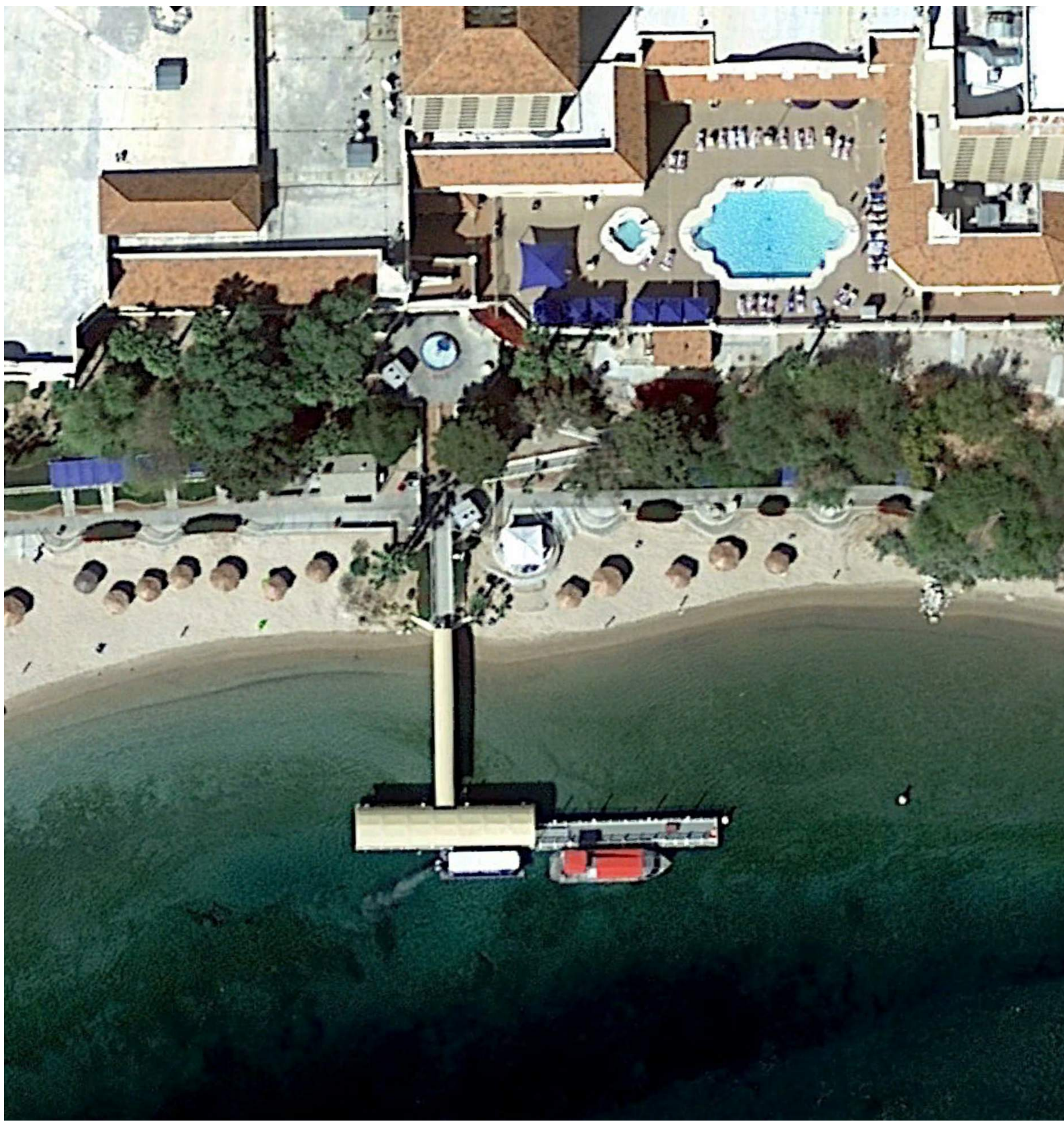

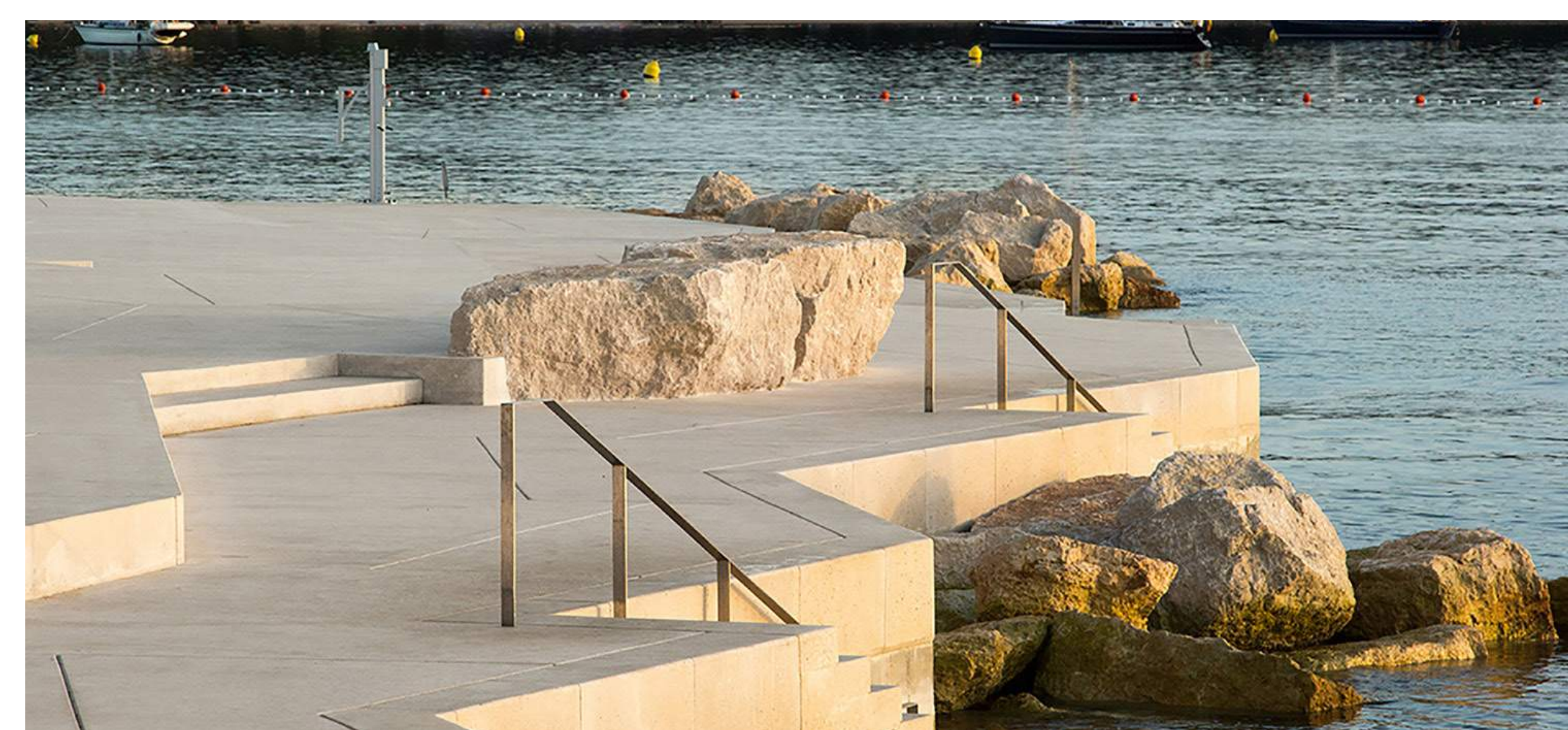



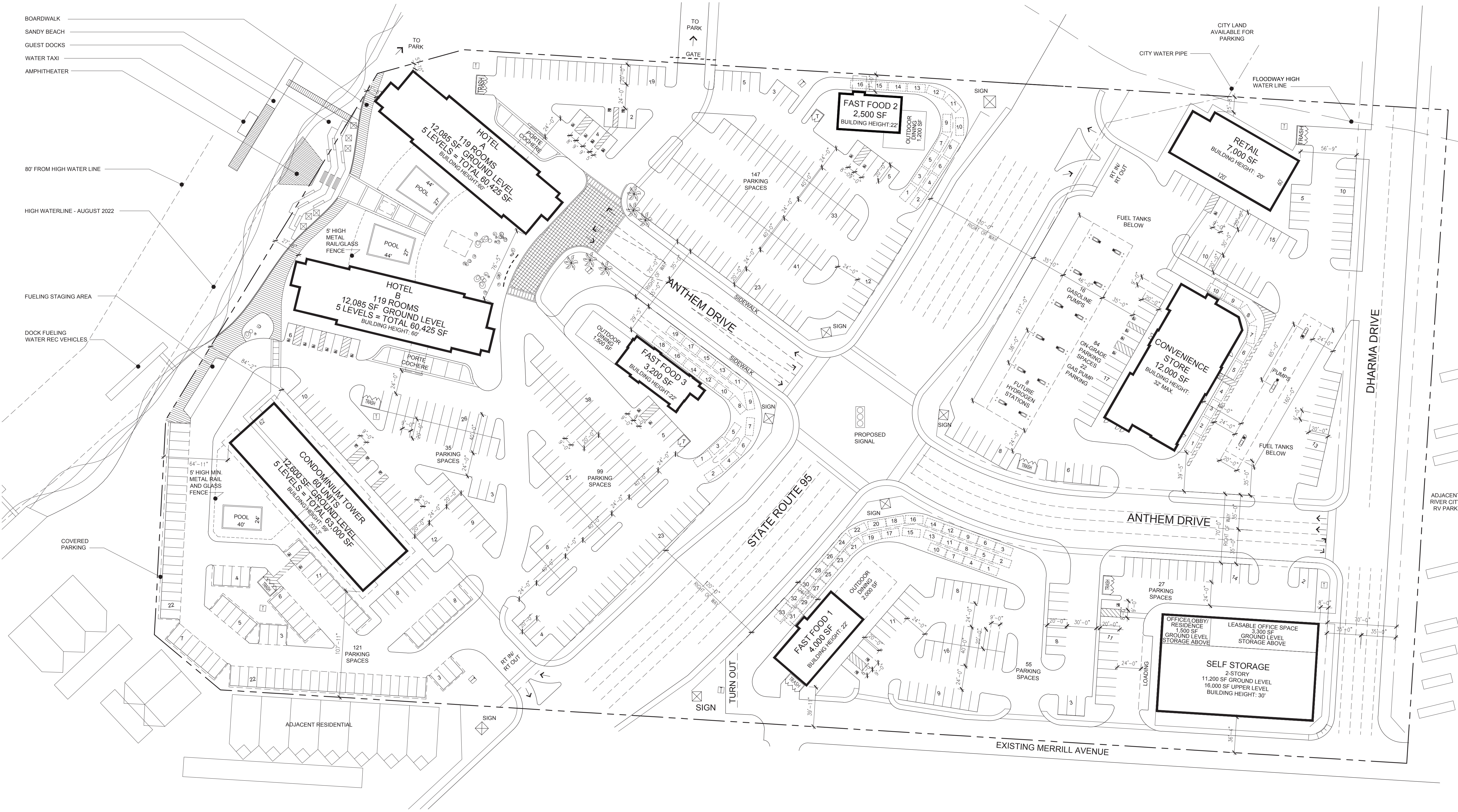

Summary

Land area	696,457 SF (15.99 Acres)
Building area	244,550 SF
Land to building ratio	2.85/1
Land coverage	11.7%
Parking required	581 spaces
Parking provided	590 spaces

Use	units	Square footage	Parking required
Hotel A	119 rooms	60,425 SF	125 spaces
Hotel B	119 rooms	60,425 SF	125 spaces
Condominium	38 (1-bedroom) 22 (2-bedroom) total 60 units	63,000 SF	67 spaces 50 spaces
Fast Food 1		4,000 SF	47 spaces
Fast Food 2		2,500 SF	30 spaces
Fast Food 3		3,200 SF	38 spaces
Convenience/ Gas Station		12,000 SF	48 spaces
Retail		7,000 SF	28 spaces
Self Storage		27,200 SF	6 spaces
Lobby/Residence		1,500 SF	4 spaces
Office		3,300 SF	13 spaces
Total		244,550 SF	581 spaces

Bullhead City Parking Requirements

Hotel	1 space per room Plus space 1 per every 3 employees
Condo/MultiFamily	1-bdrm 1.75 space/unit 2-bdrm 2.25space/unit
Retail	1 space/250 SF
Fast Food	1 space/100 SF, plus 1 space/employee 8 vehicular stacking -minimum
Convenience/Gas Station	1 space/300 SF, plus 1 space/employee Gas pumps count as parking spaces
Self-Storage	3 spaces, plus 1 space per 100 storage units
Office	1 space /250 SF

- Notes:**
- The maximum building height allowed, sixty feet or five stories, whichever is less.
 - Trash bins to be screened by 6' high walls - see detail A
 - Typical parking spaces to be 9'x20' - see detail B
 - Sign review per sign program to be submitted at a future date.
 - All exterior light fixtures to be shielded and directed down ward. All overhead lighting shall be directed away from or shielded from adjacent residential lots.

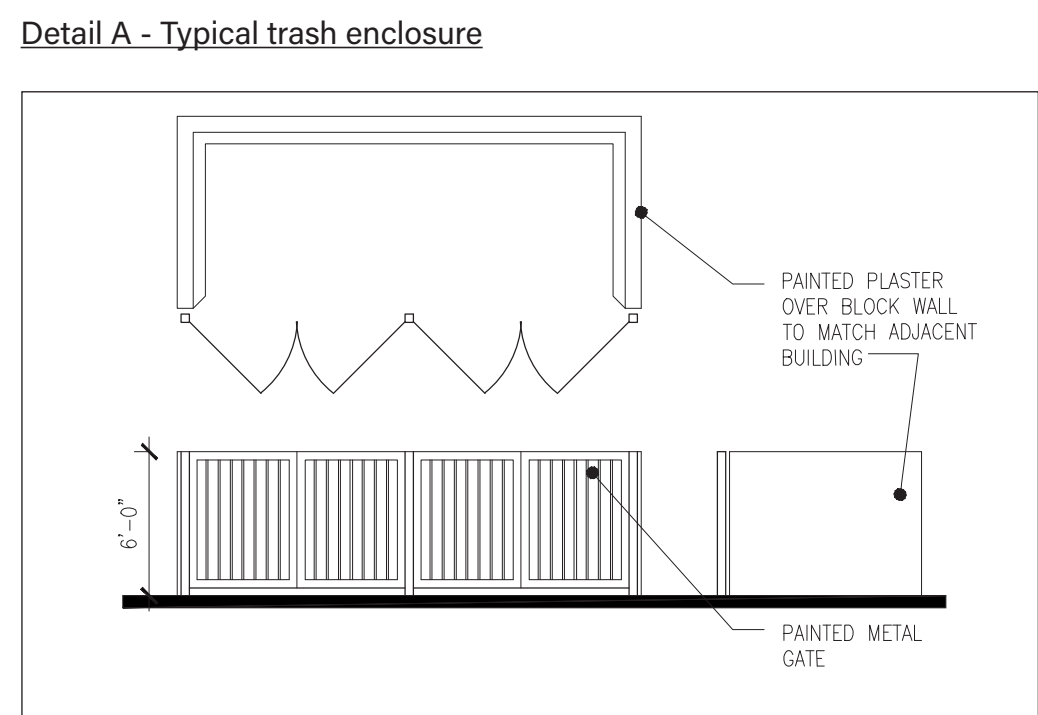
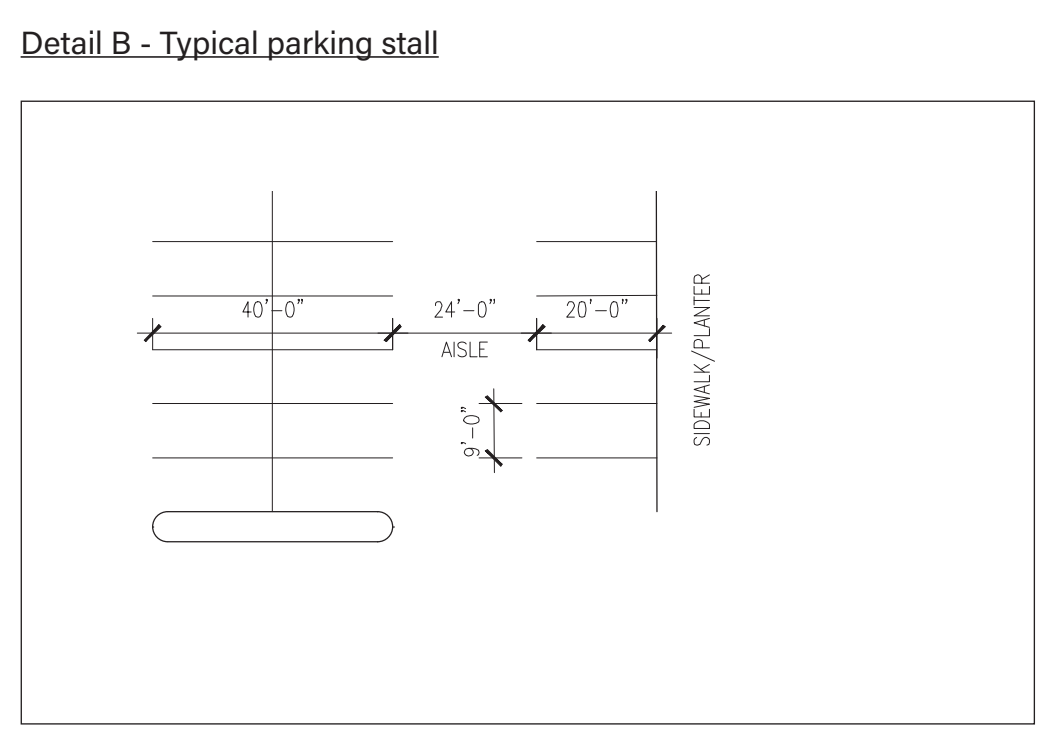

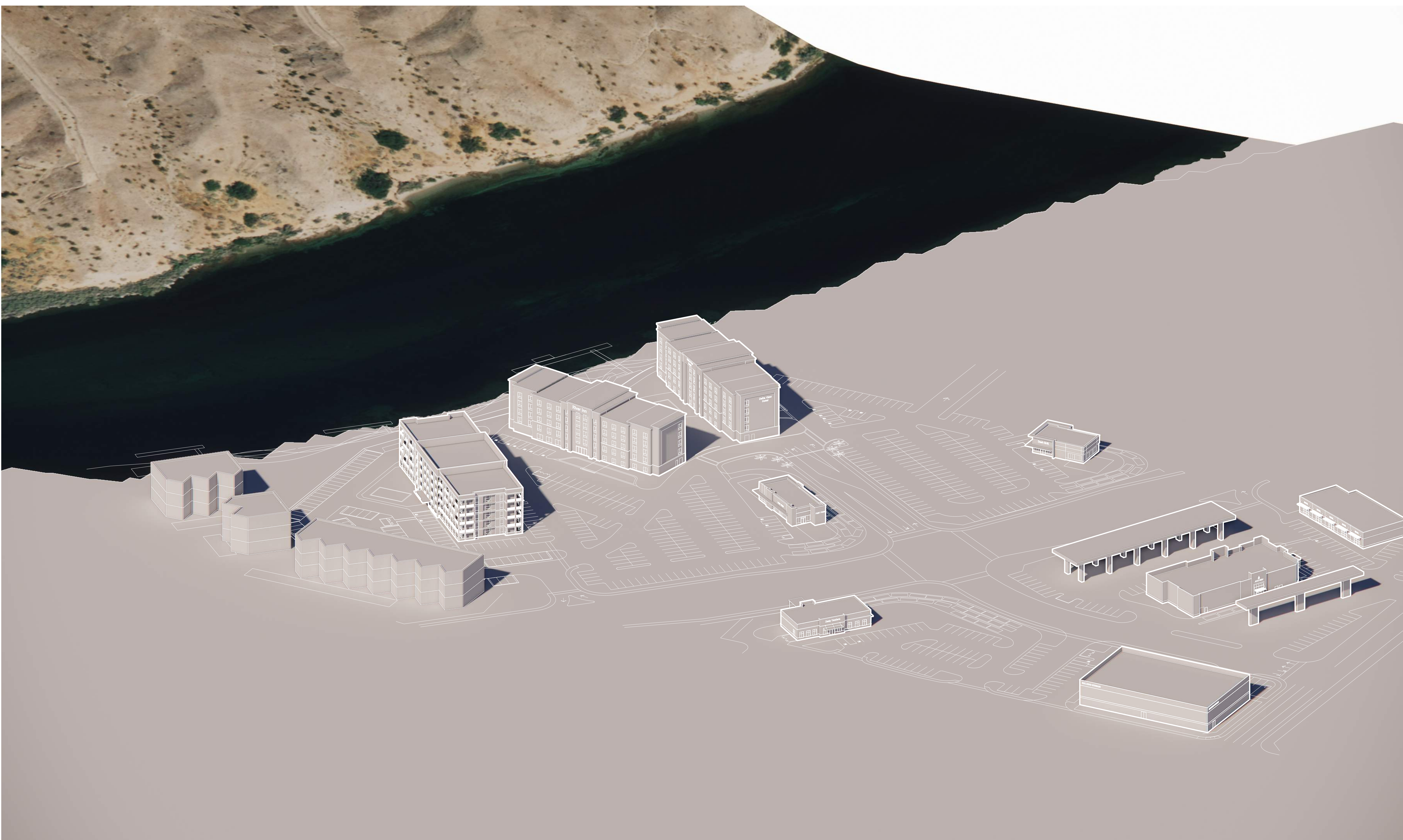

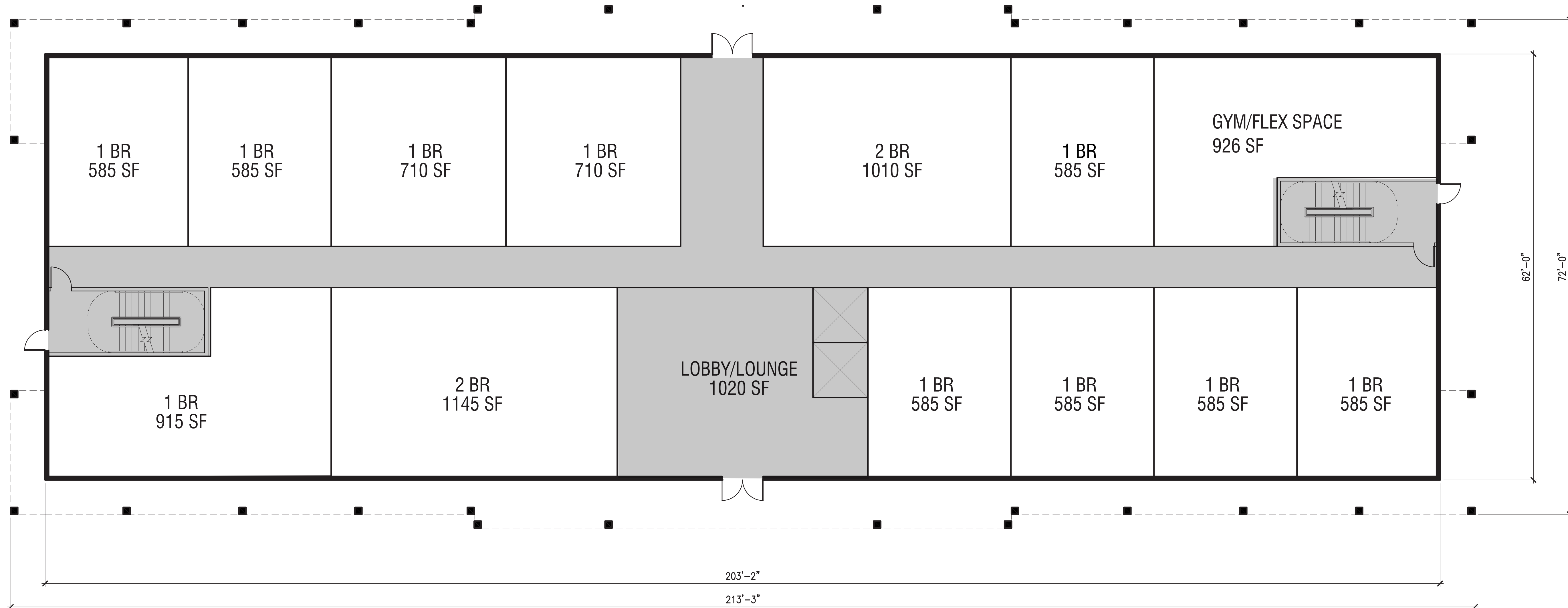

LEVEL 1

CONDO UNIT SUMMARY

FLOOR	UNIT #
Level 1	12
Level 2	12
Level 3	12
Level 4	12
Level 5	12
TOTAL UNITS	60

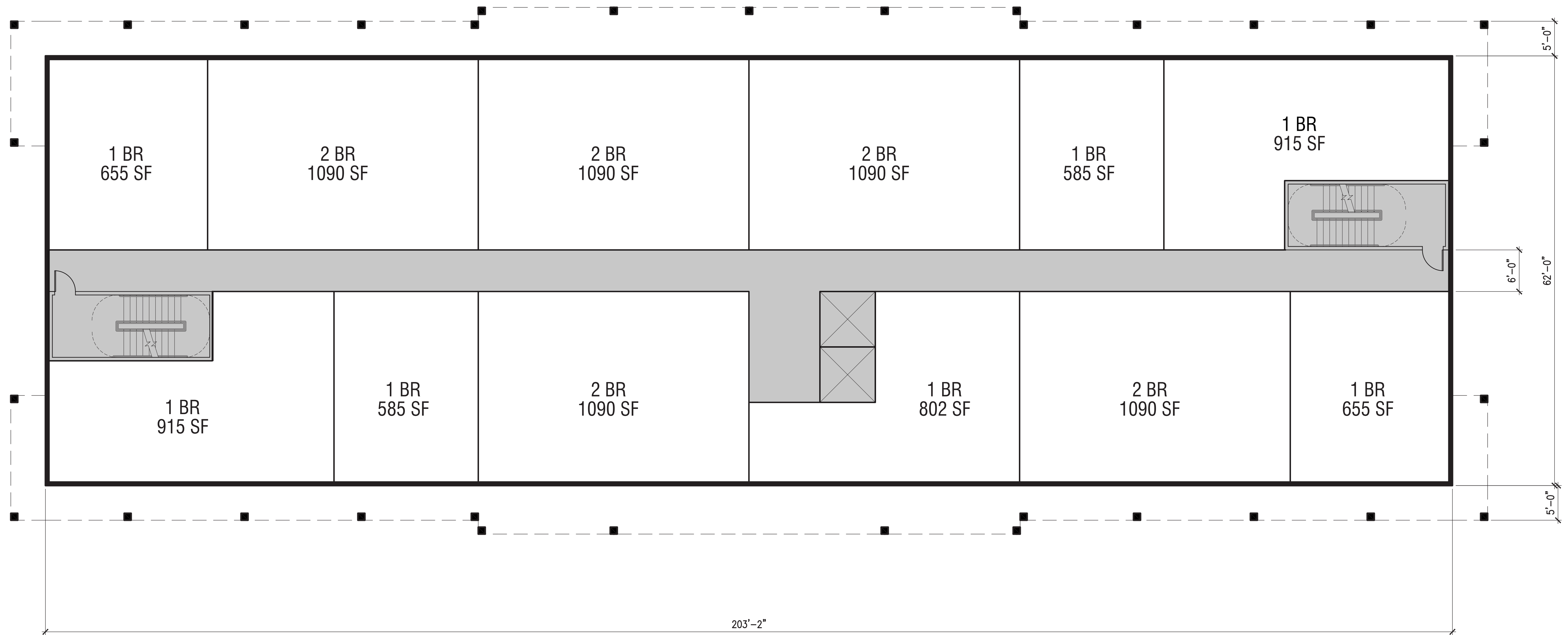

LEVEL 2 - 5

CONDO UNIT SUMMARY

FLOOR	UNIT #
Level 1	12
Level 2	12
Level 3	12
Level 4	12
Level 5	12
TOTAL UNITS	60

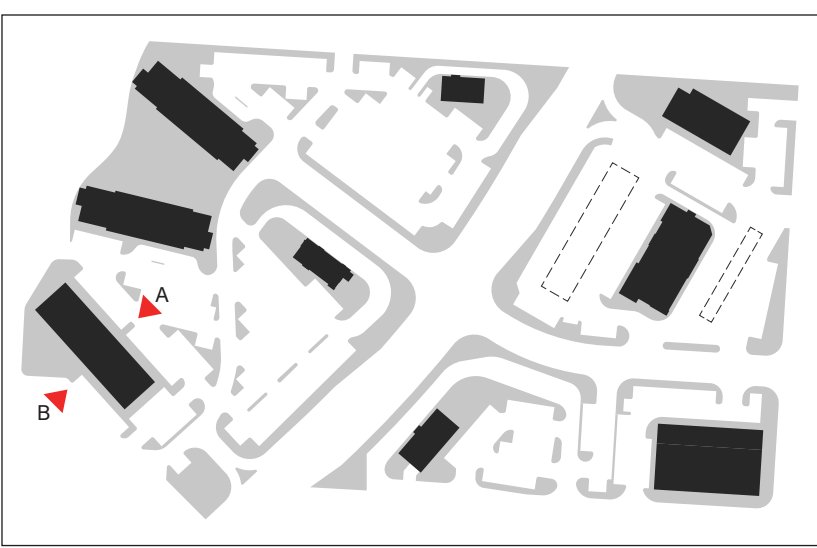

A - NORTH ELEVATION



B - SOUTH ELEVATION

**60' MAX HEIGHT LIMIT

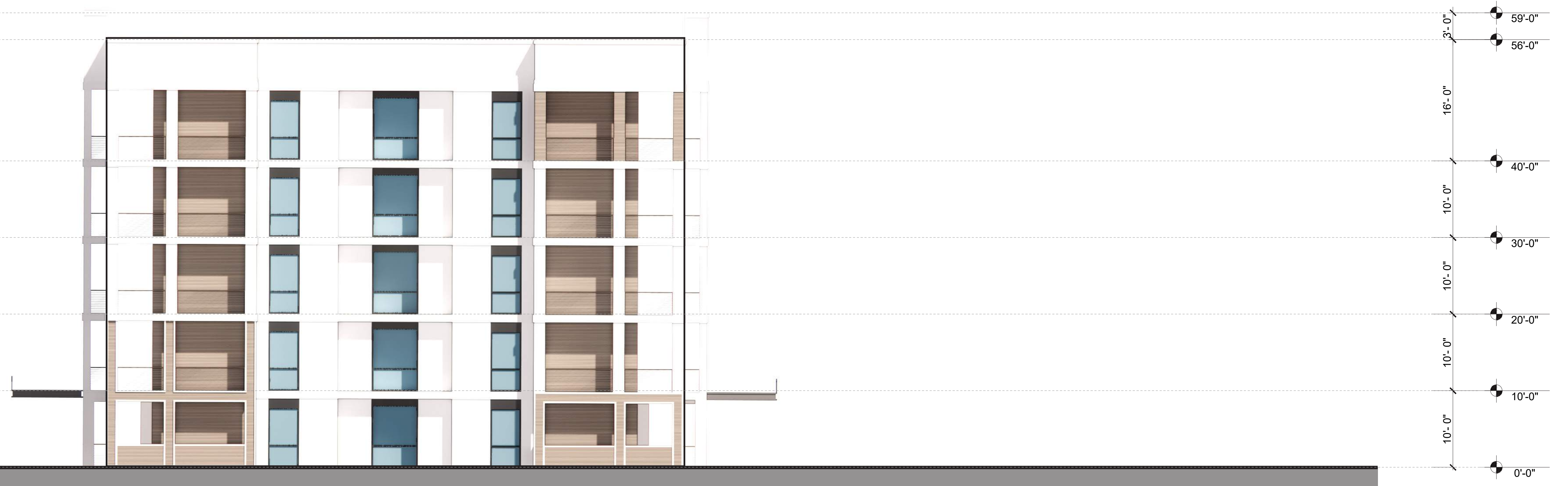

C - EAST ELEVATION

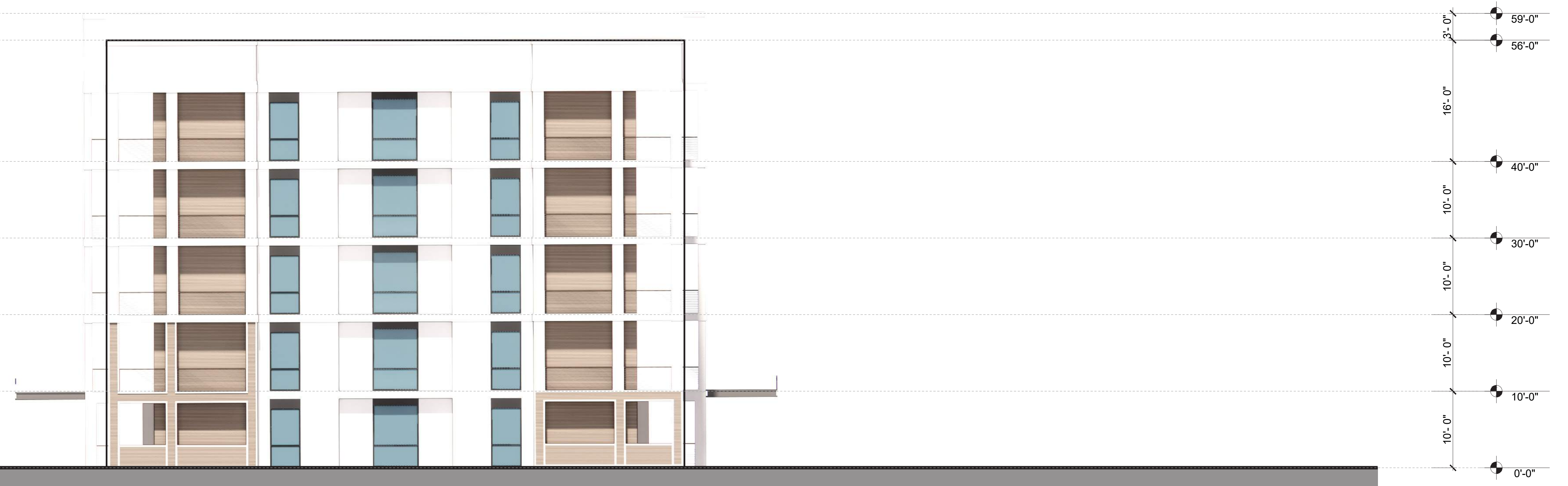

D - WEST ELEVATION

**60' MAX HEIGHT LIMIT

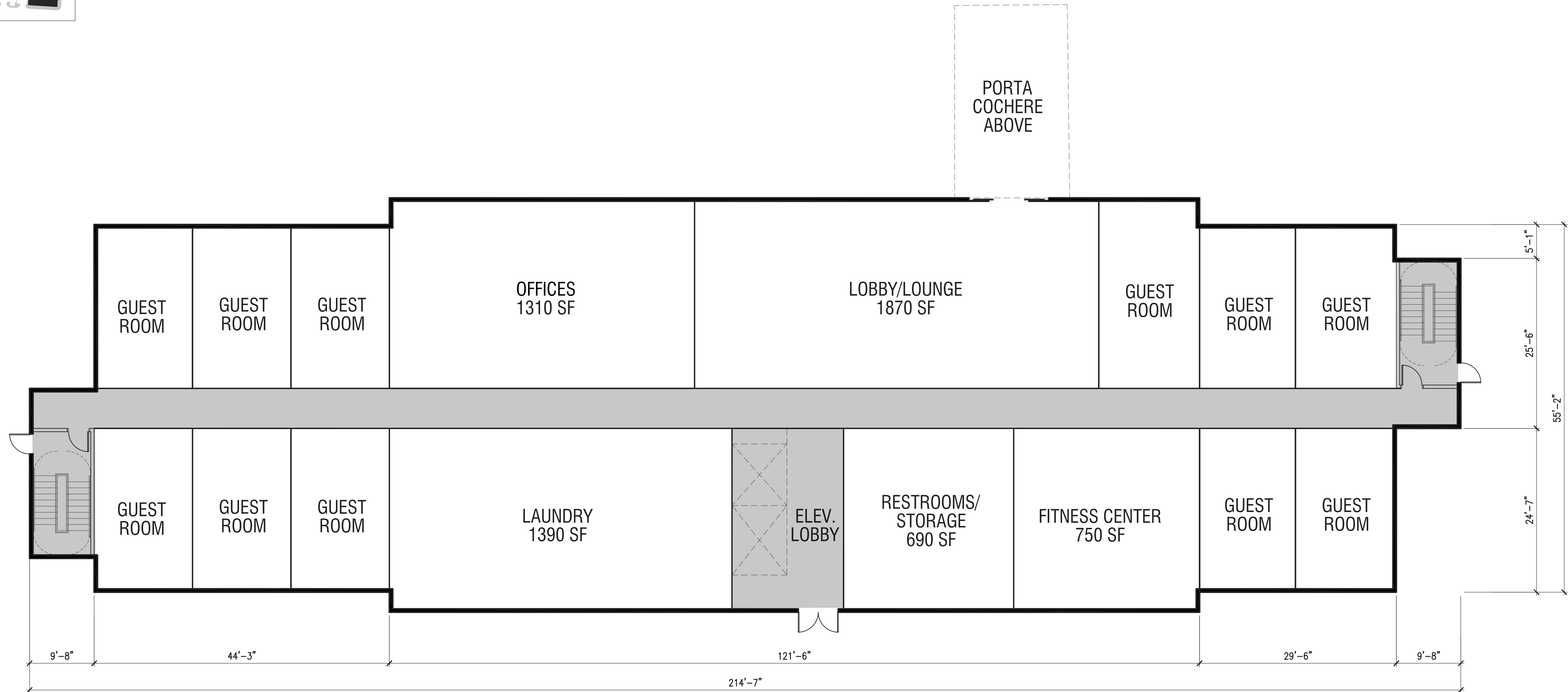
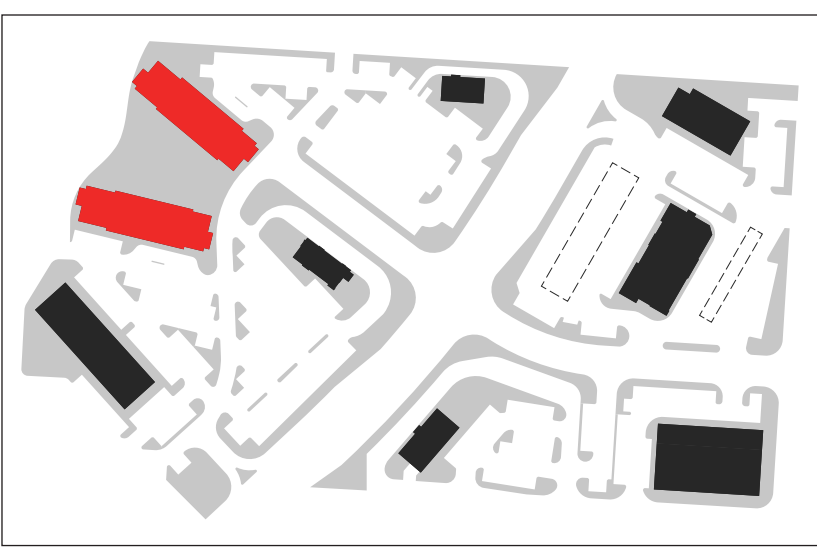

LEVEL 1

HOTEL A & B UNIT SUMMARY

FLOOR	UNIT #
Level 1	11
Level 2	27
Level 3	27
Level 4	27
Level 5	27
TOTAL UNITS	119

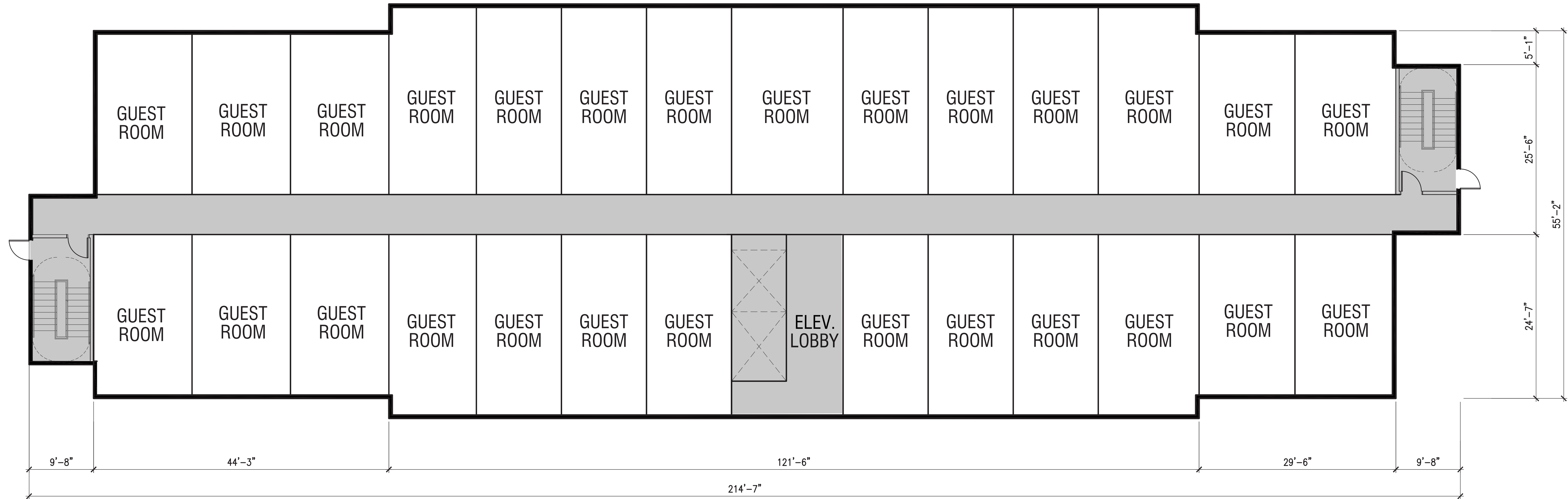
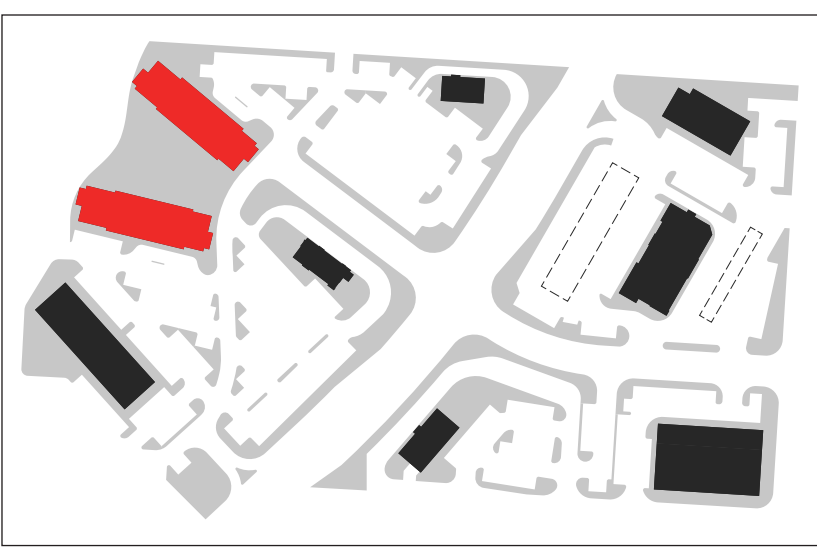

LEVEL 2-5

HOTEL A & B UNIT SUMMARY

FLOOR	UNIT #
Level 1	11
Level 2	27
Level 3	27
Level 4	27
Level 5	27
TOTAL UNITS	119

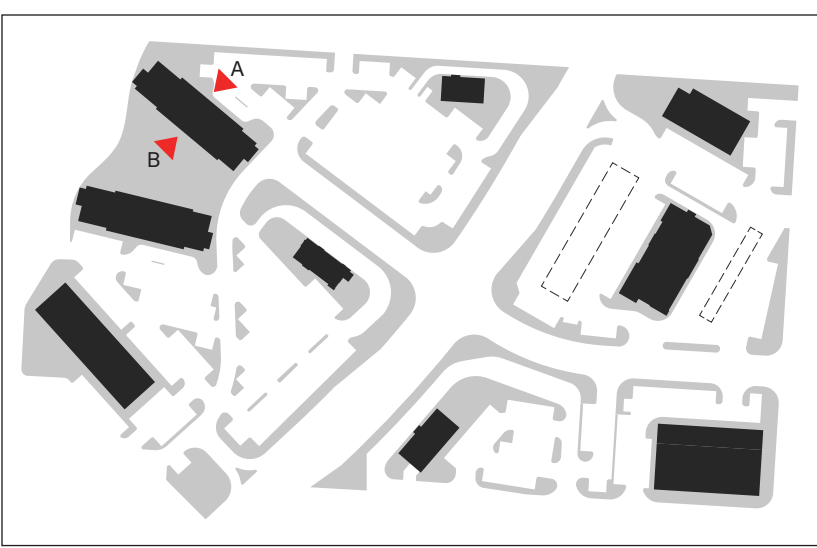

A - NORTH ELEVATION



B - SOUTH ELEVATION

**60' MAX HEIGHT LIMIT

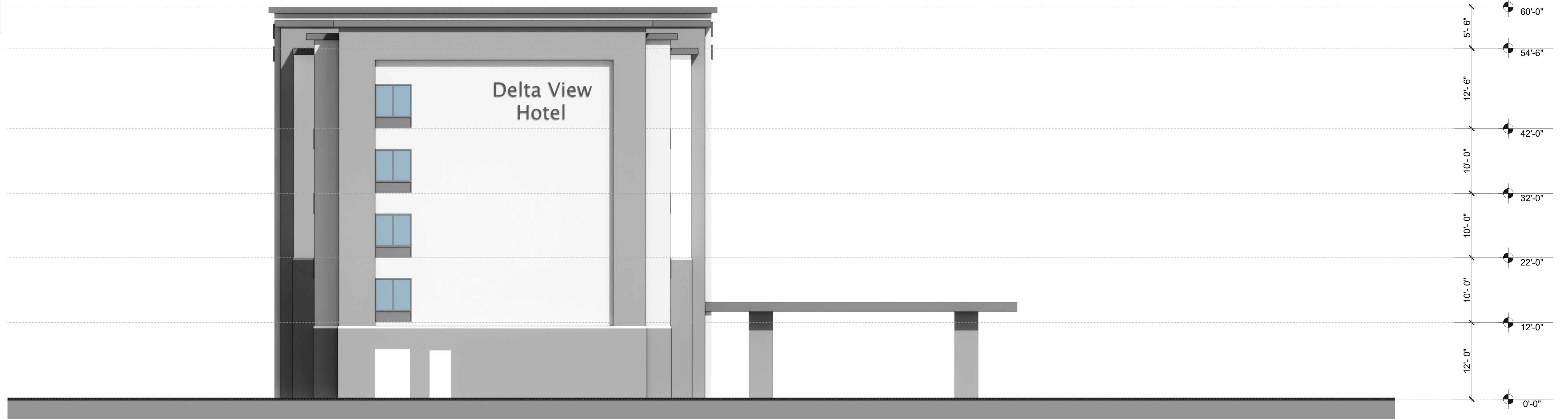
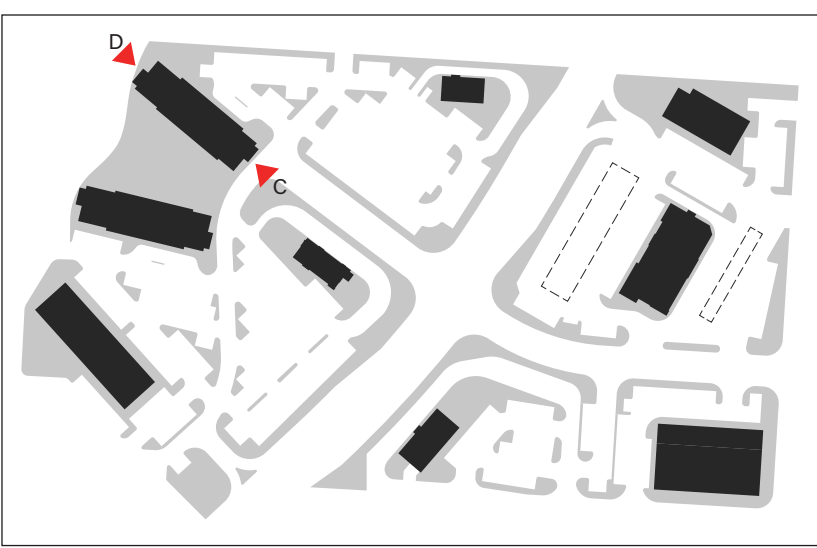

C - EAST ELEVATION

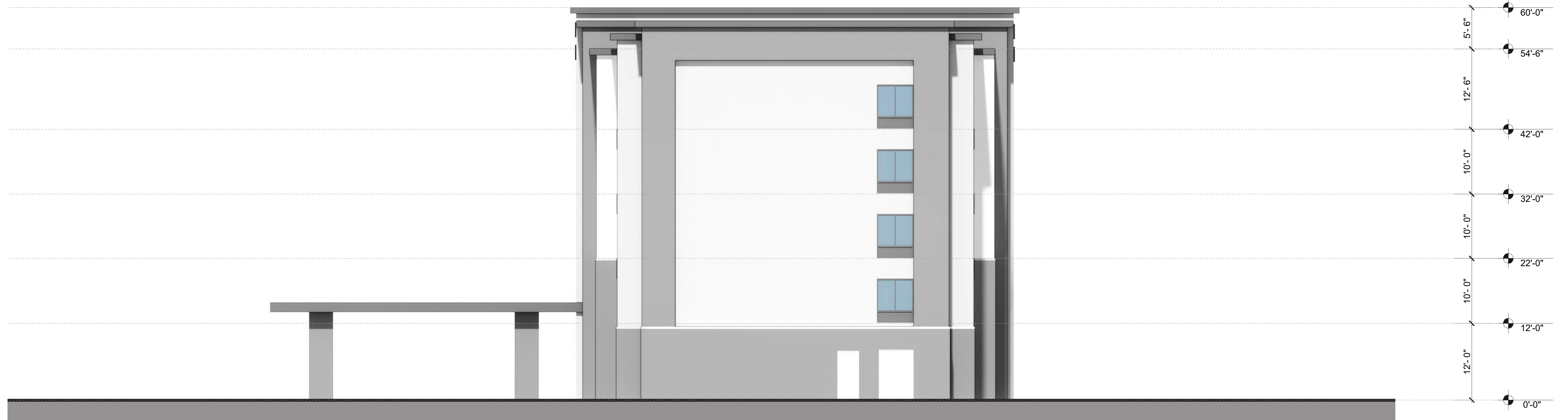

D - WEST ELEVATION

**60' MAX HEIGHT LIMIT

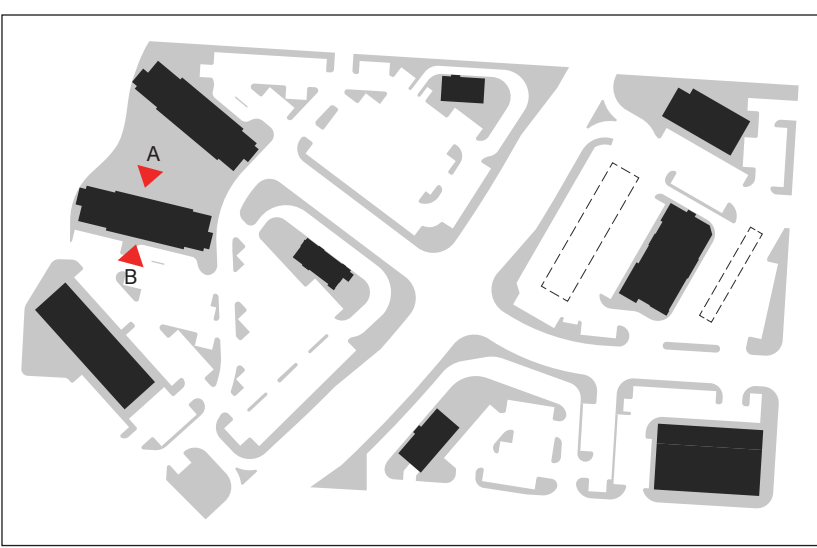

A - NORTH ELEVATION



B - SOUTH ELEVATION

**60' MAX HEIGHT LIMIT

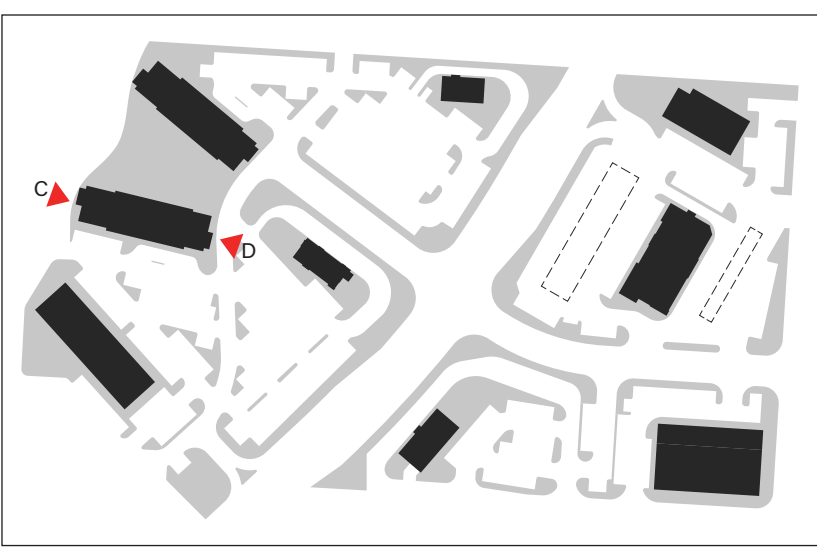

C - WEST ELEVATION



D - EAST ELEVATION

**60' MAX HEIGHT LIMIT

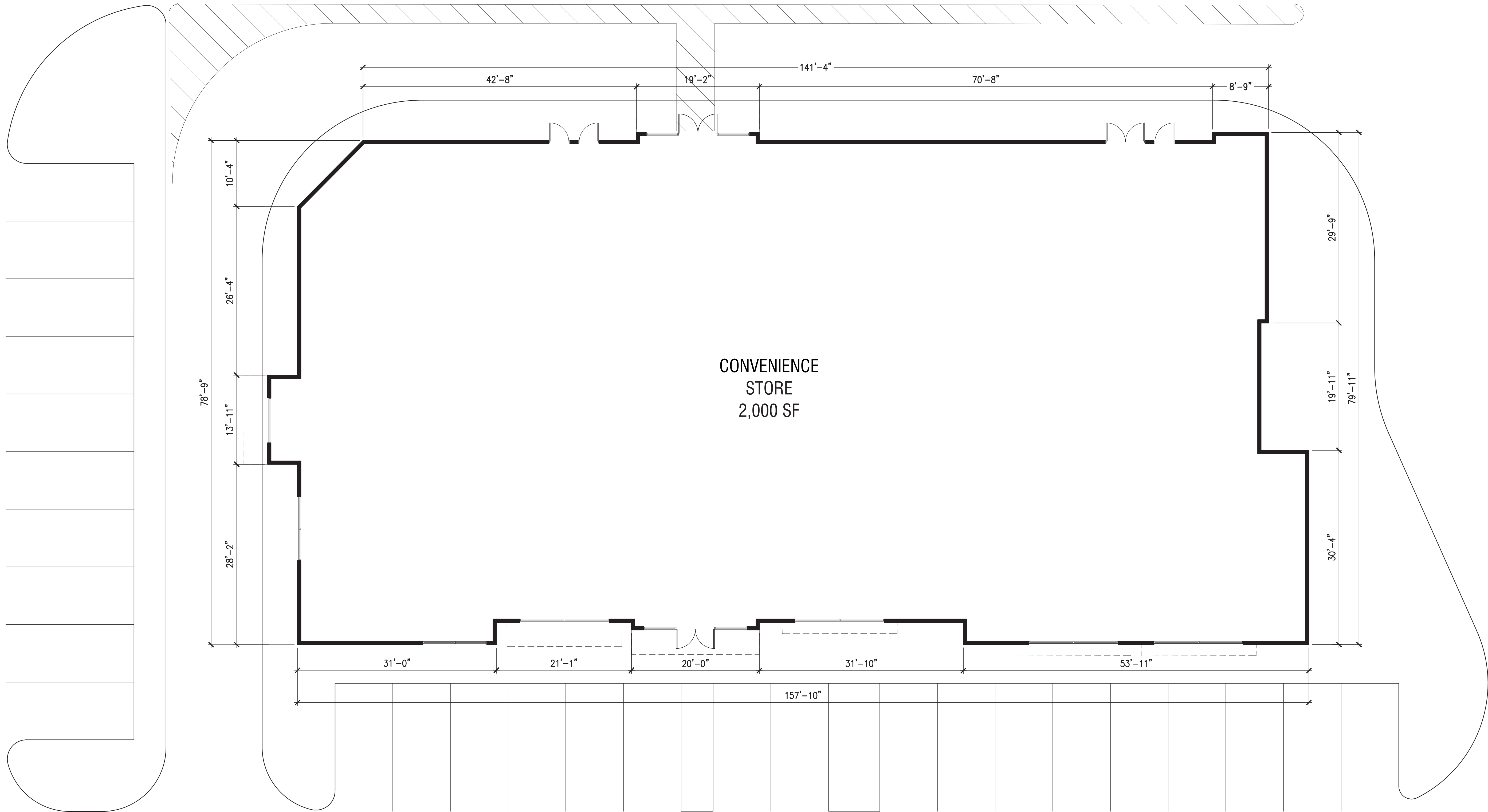
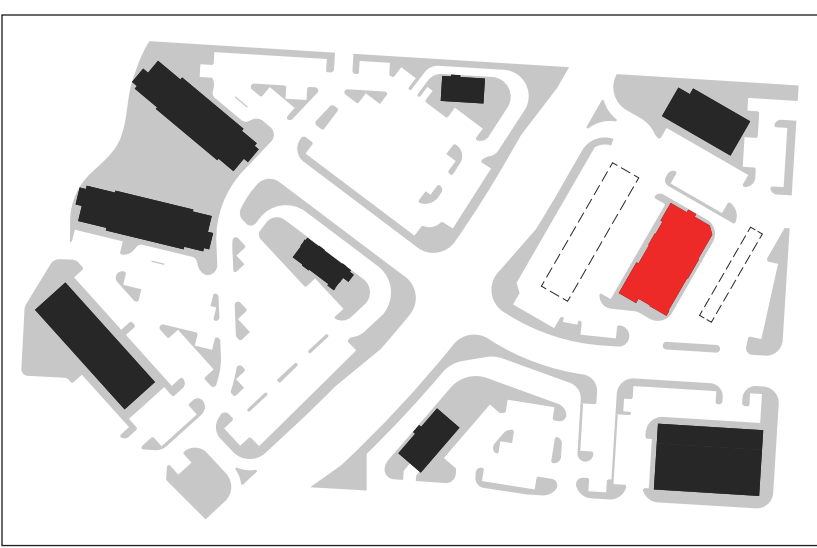

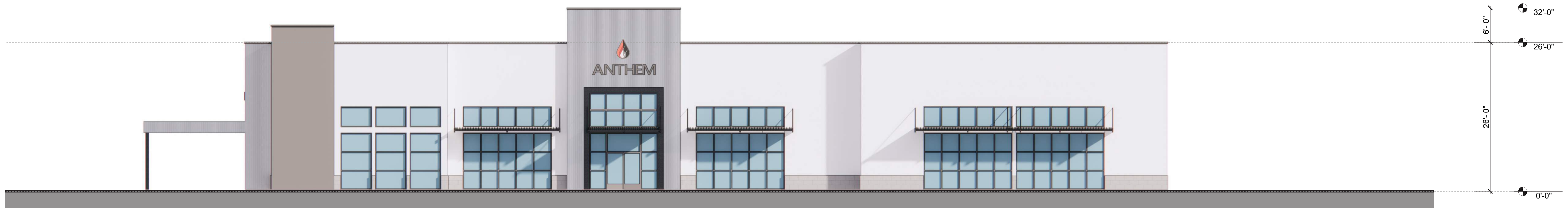
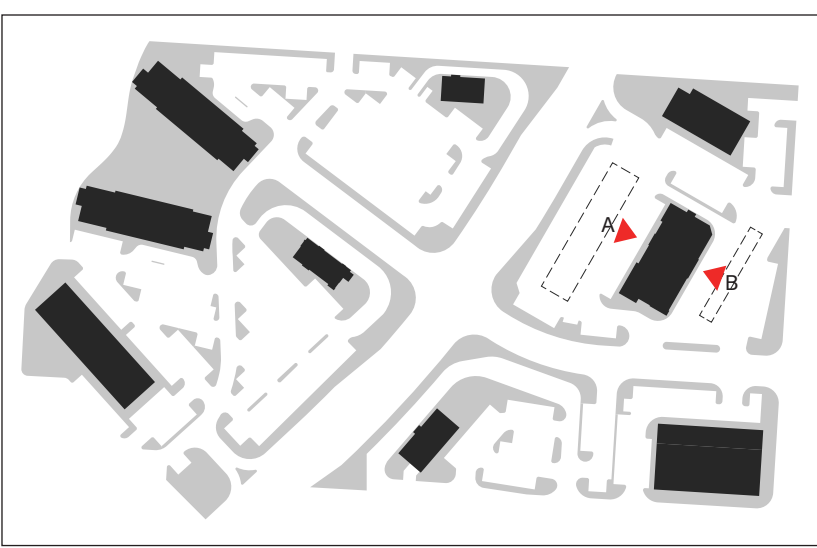

A - WEST ELEVATION



B - EAST ELEVATION

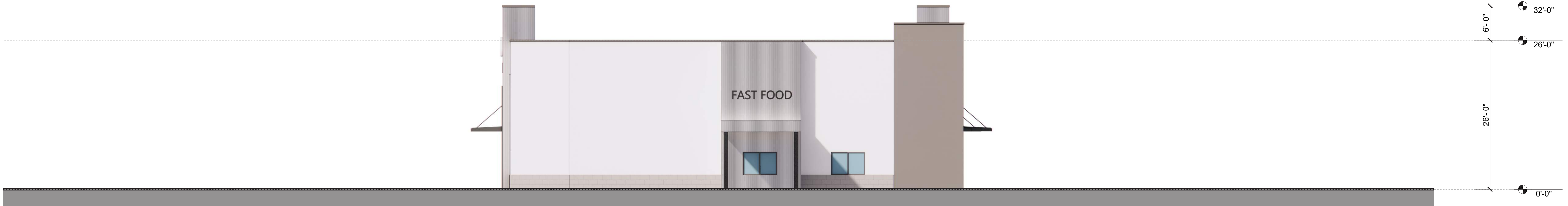
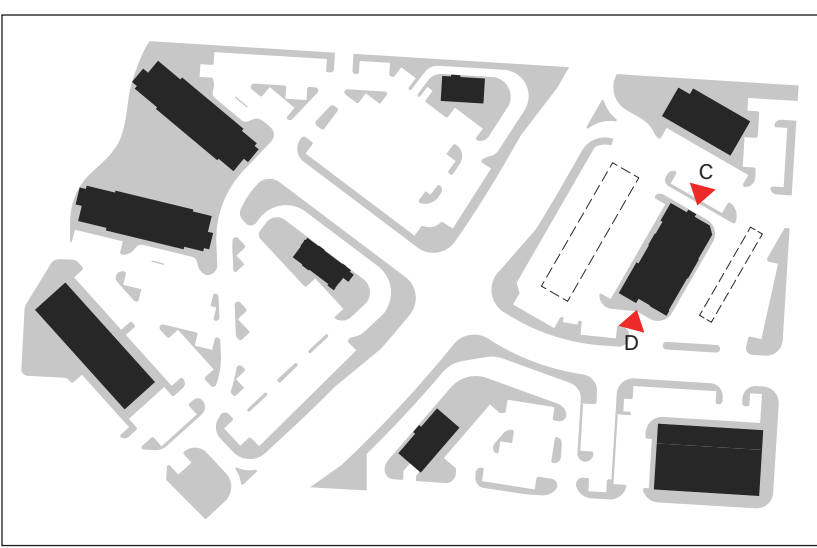

C - NORTH ELEVATION



D - SOUTH ELEVATION

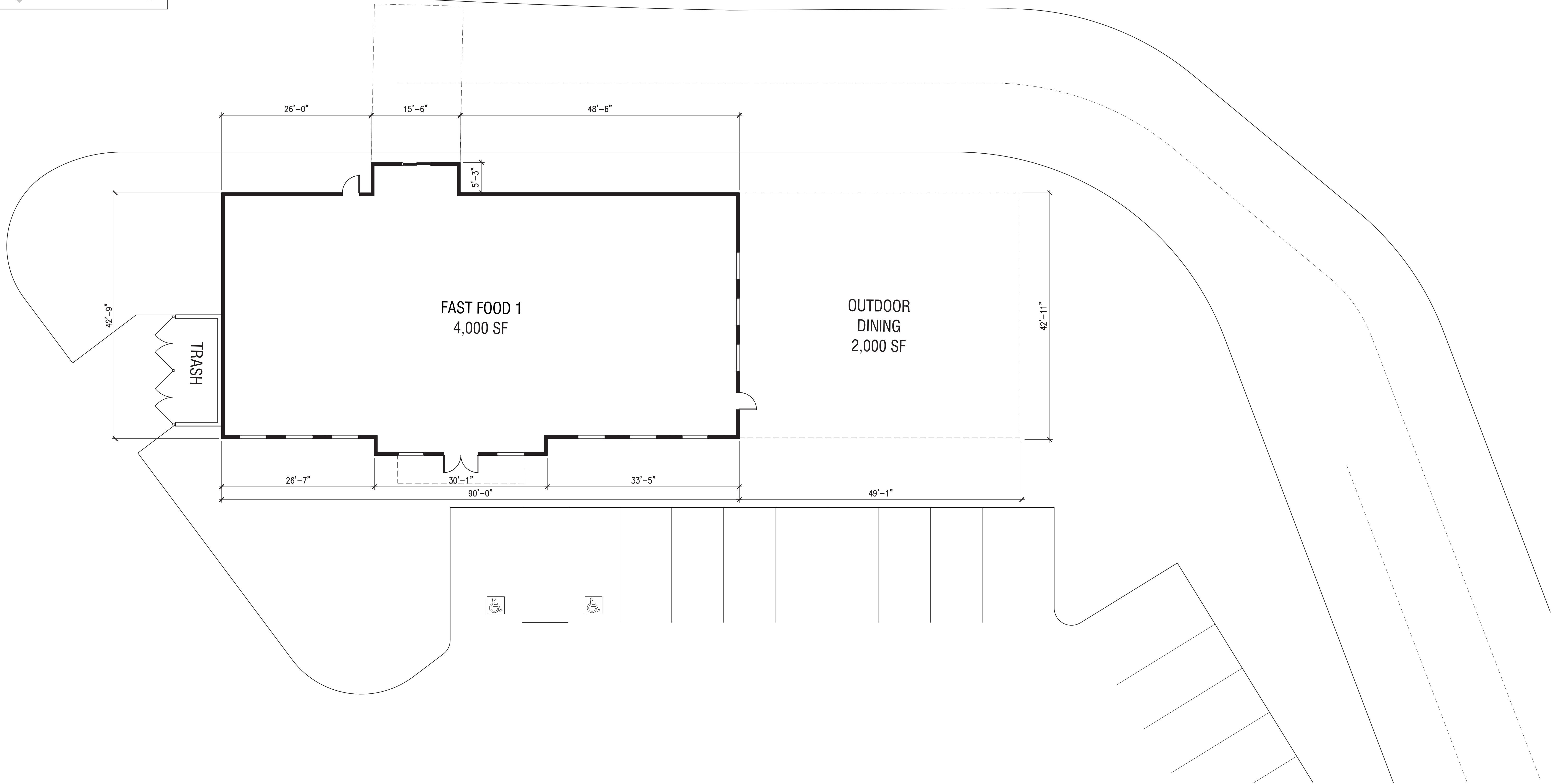
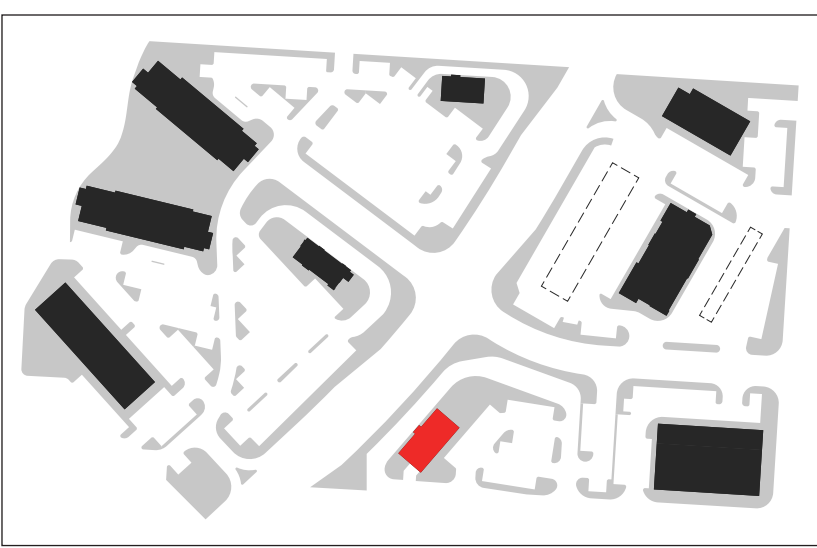

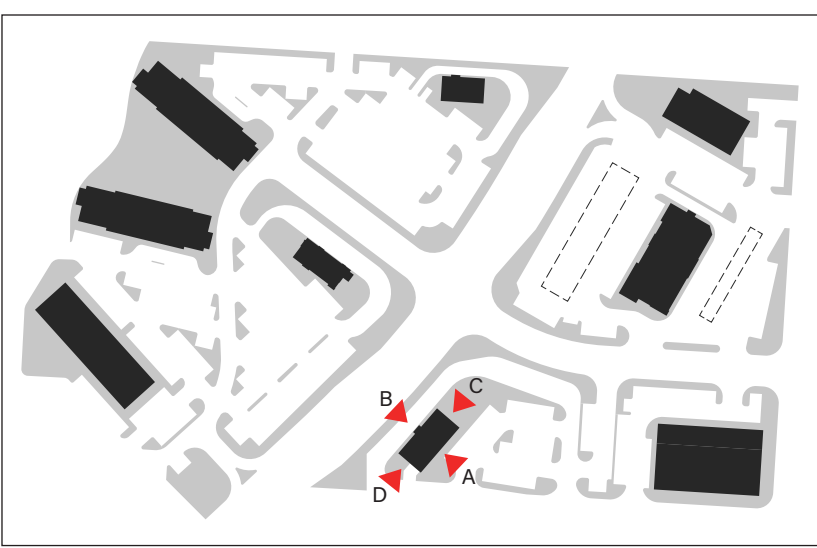

A - EAST ELEVATION



C - NORTH ELEVATION



B - WEST ELEVATION

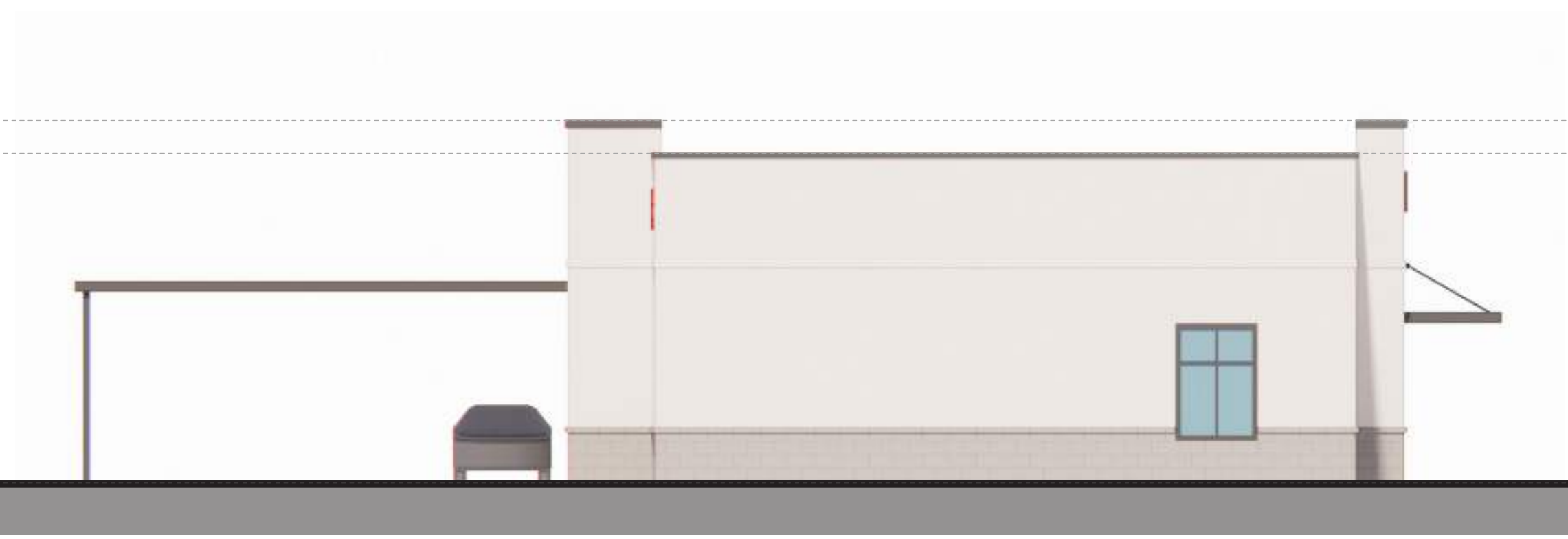

D - SOUTH ELEVATION

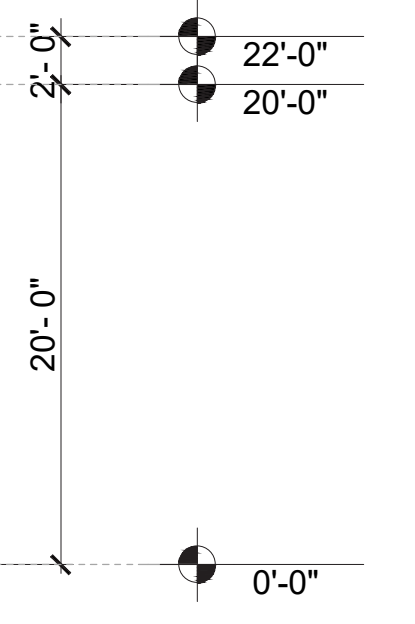
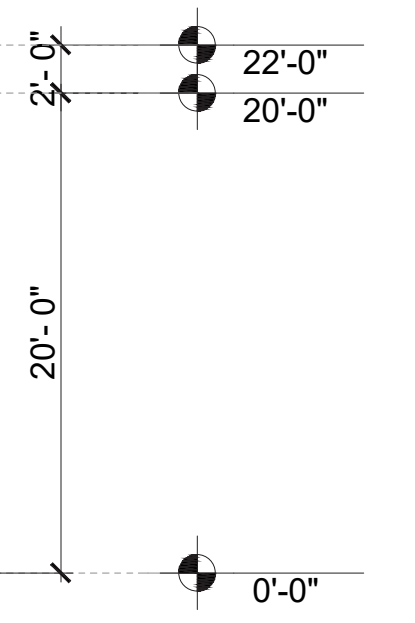

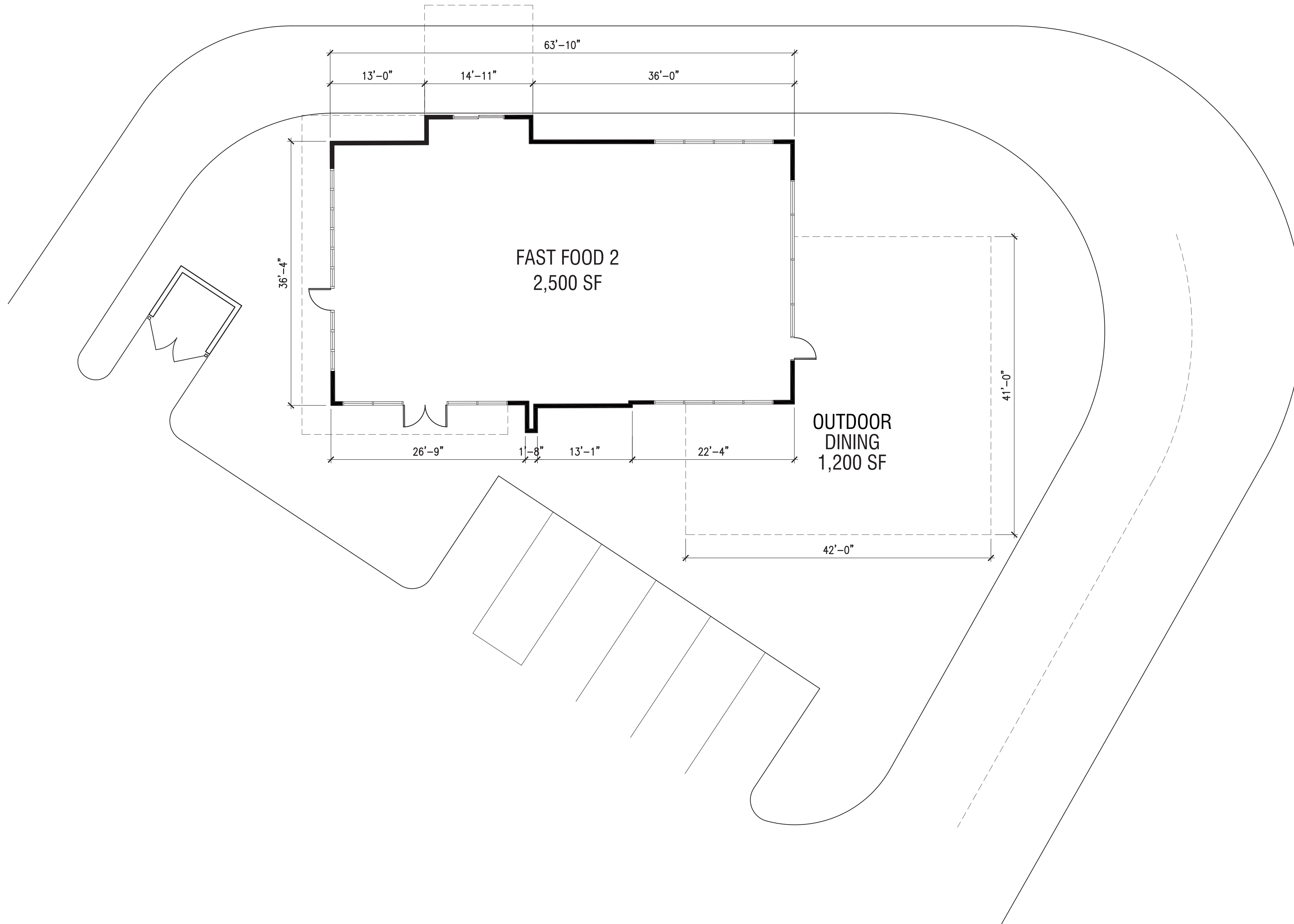
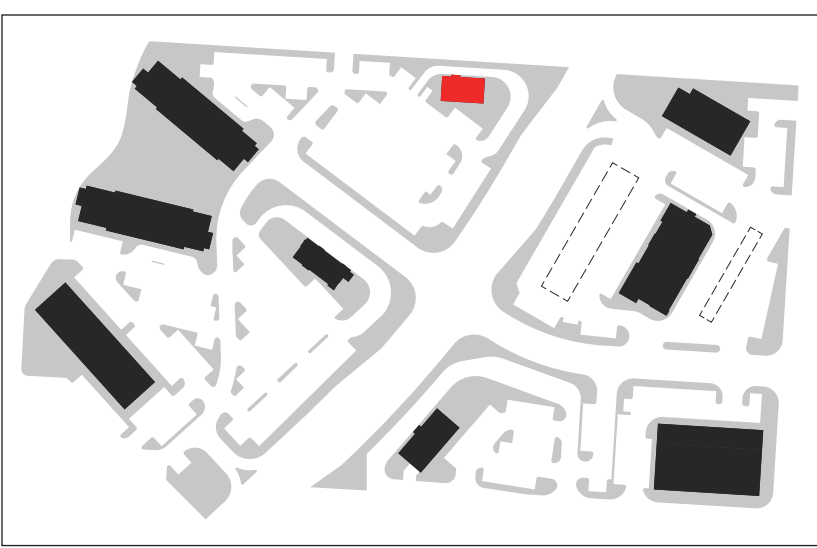

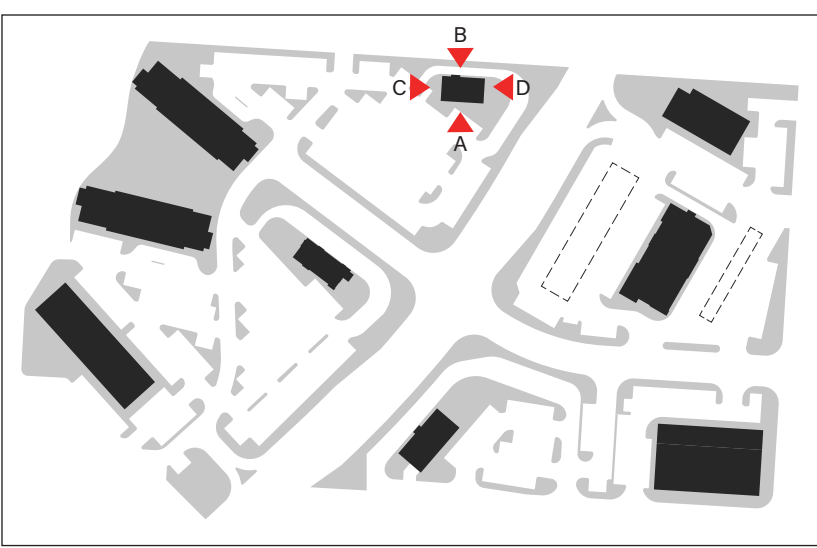

A - SOUTH ELEVATION



C - WEST ELEVATION

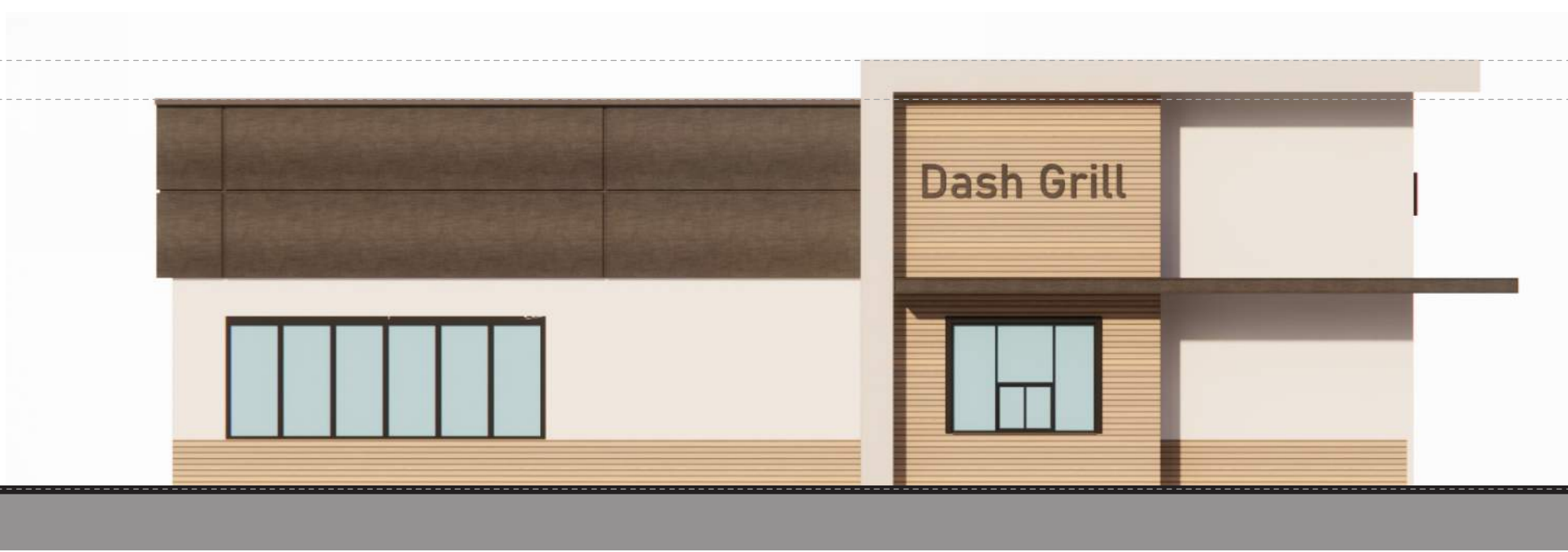

B - NORTH ELEVATION



D - EAST ELEVATION

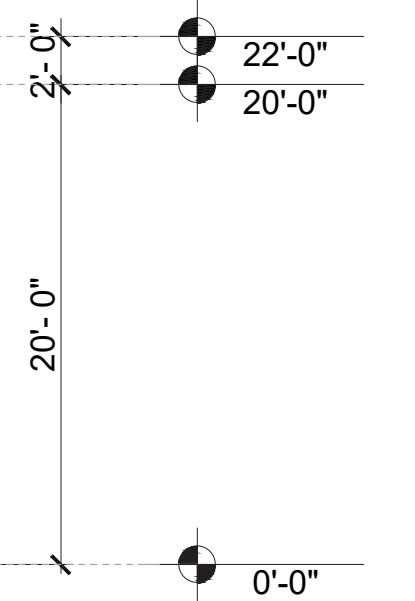
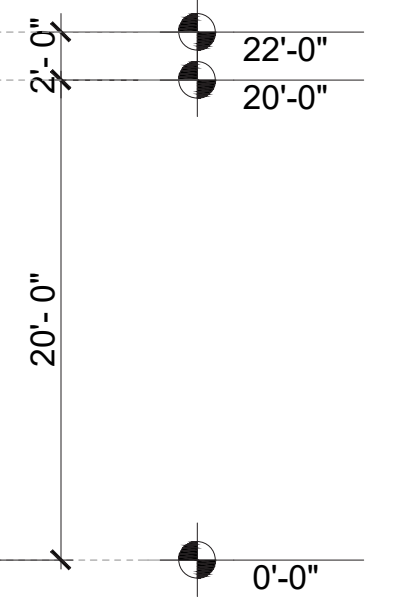

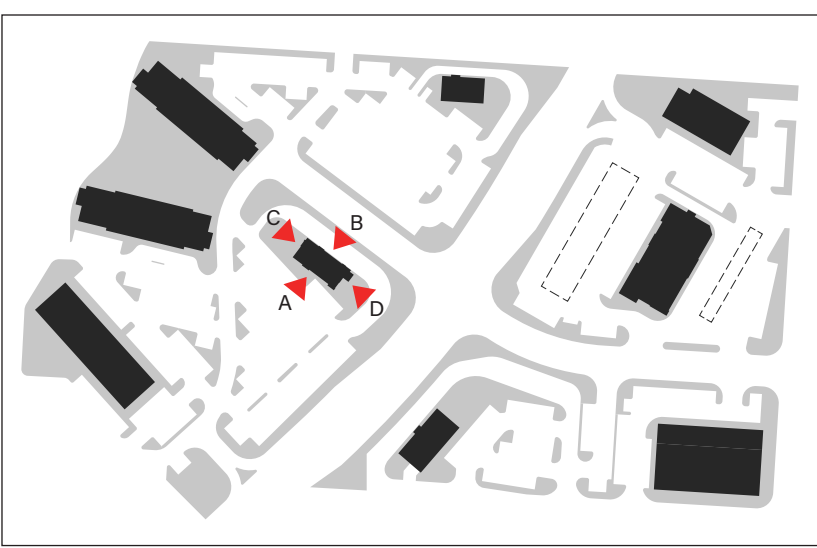

A - SOUTH ELEVATION



C - WEST ELEVATION

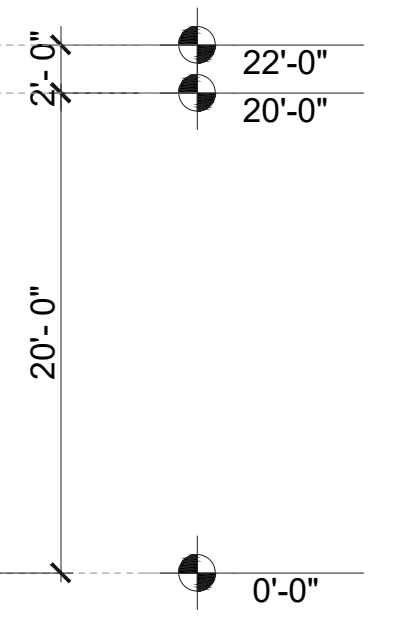

B - NORTH ELEVATION



D - EAST ELEVATION

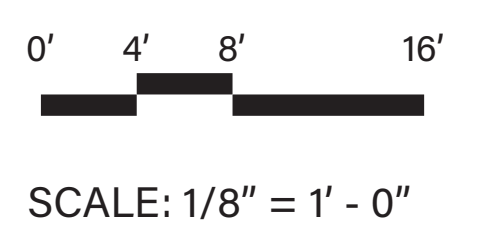
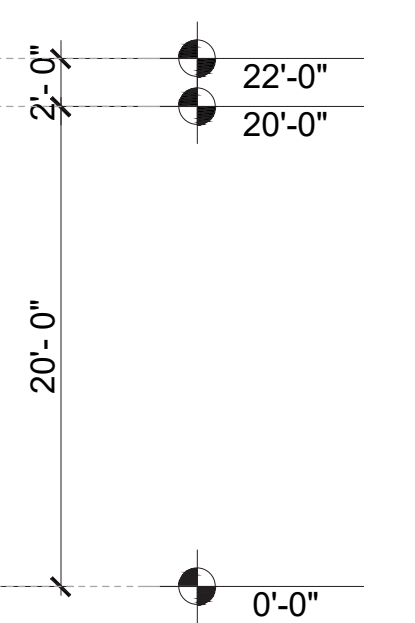

ELEVATIONS
FAST FOOD 3



SMS ARCHITECTS

January 4, 2024 | 27

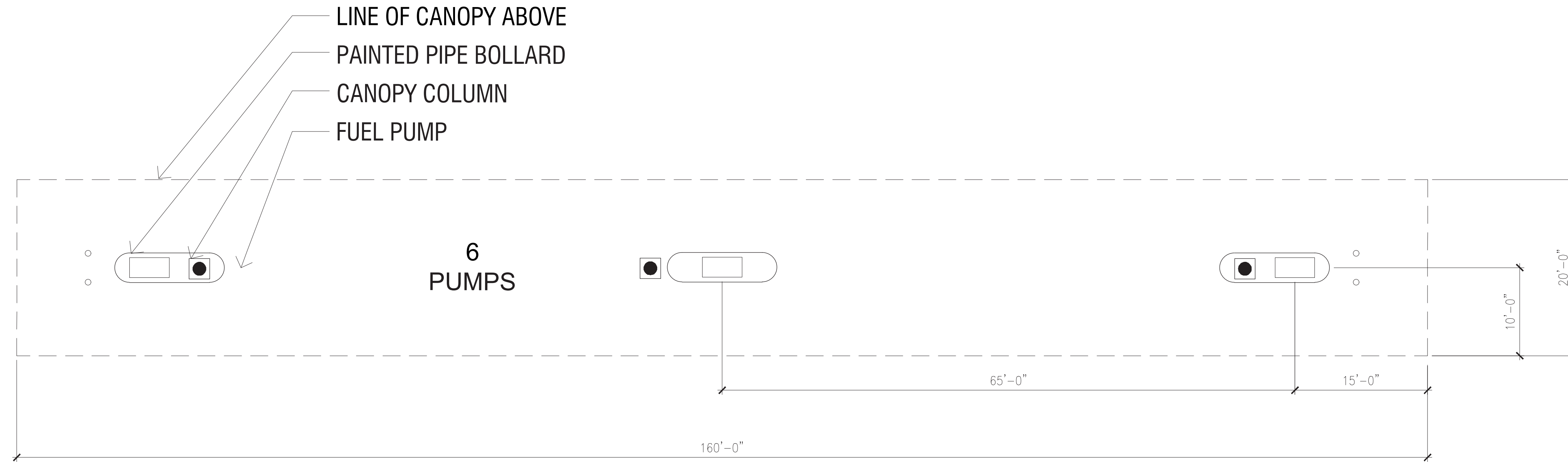

A - EAST/WEST ELEVATION

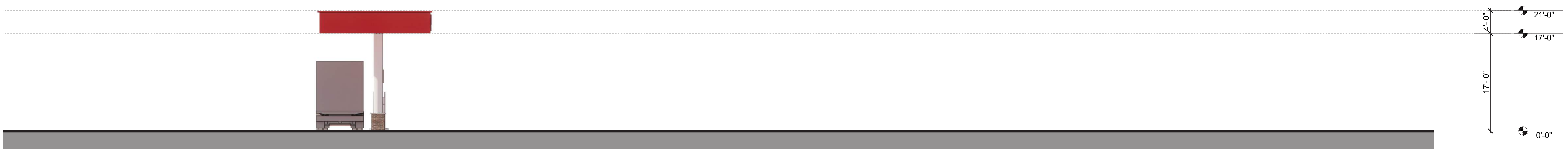

B - NORTH/SOUTH ELEVATION



- CANOPY COLUMN
- FUEL PUMP
- PAINTED PIPE BOLLARD
- LINE OF CANOPY ABOVE

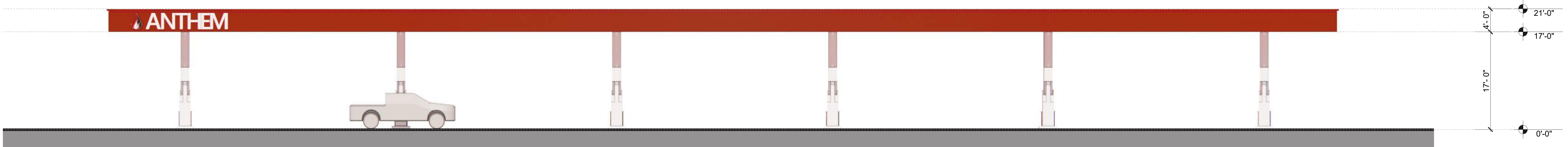
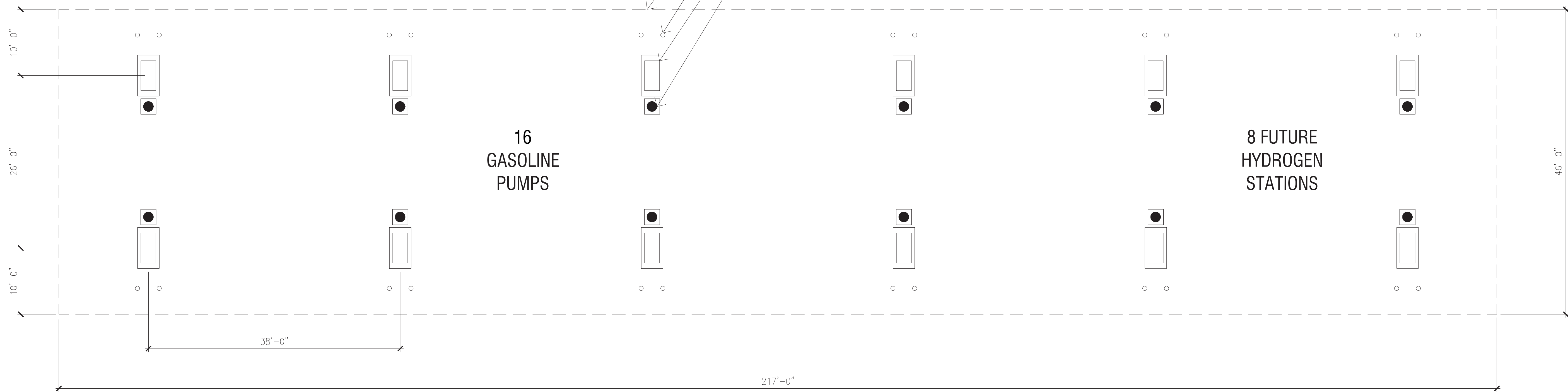

A - EAST/WEST ELEVATION



B - NORTH/SOUTH ELEVATION

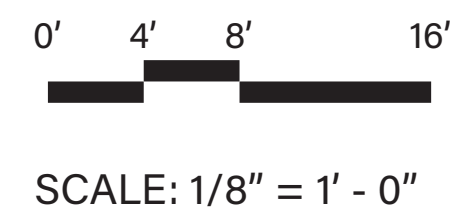

FLOOR PLAN/ELEVATIONS
GAS STATION (16 PUMPS)



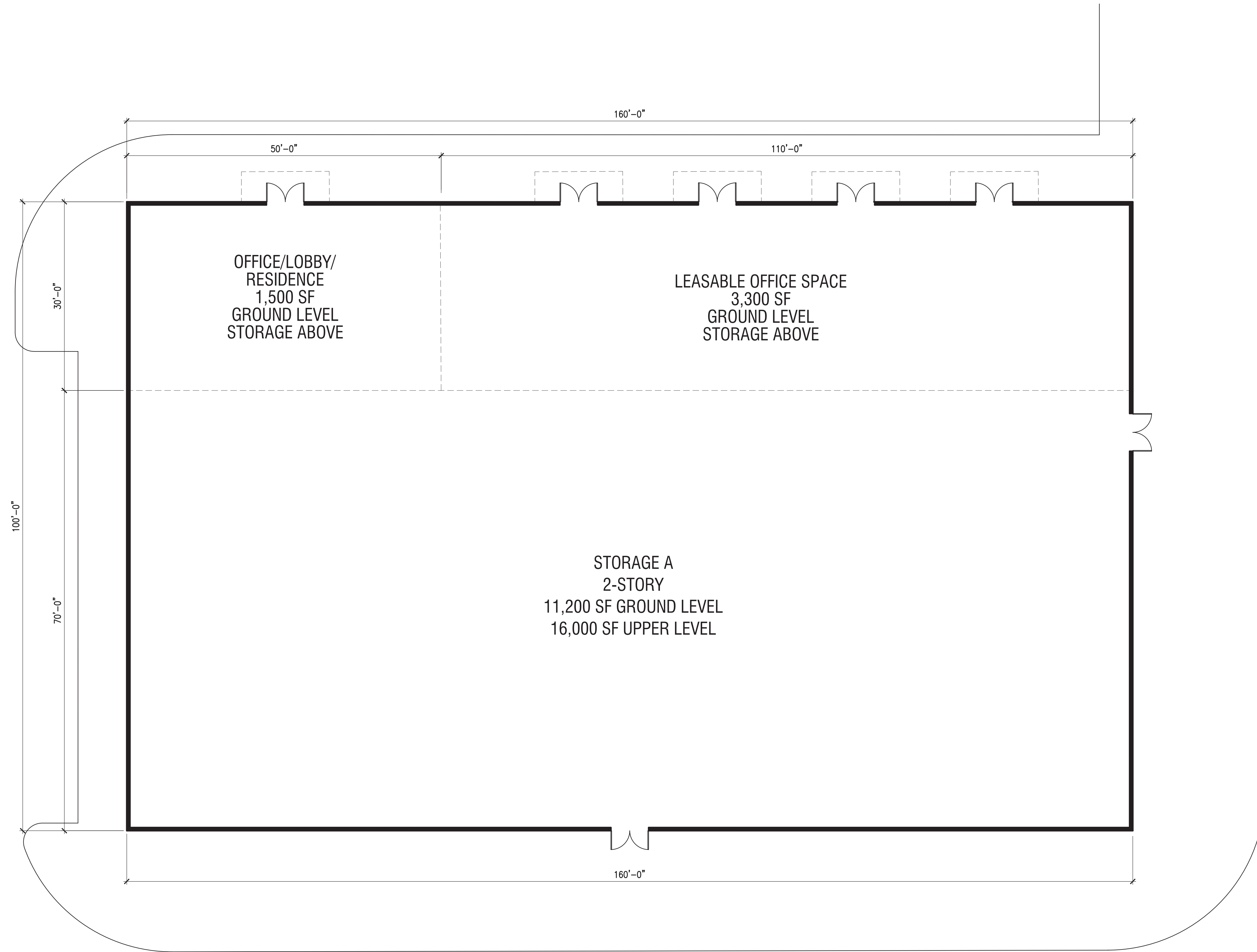
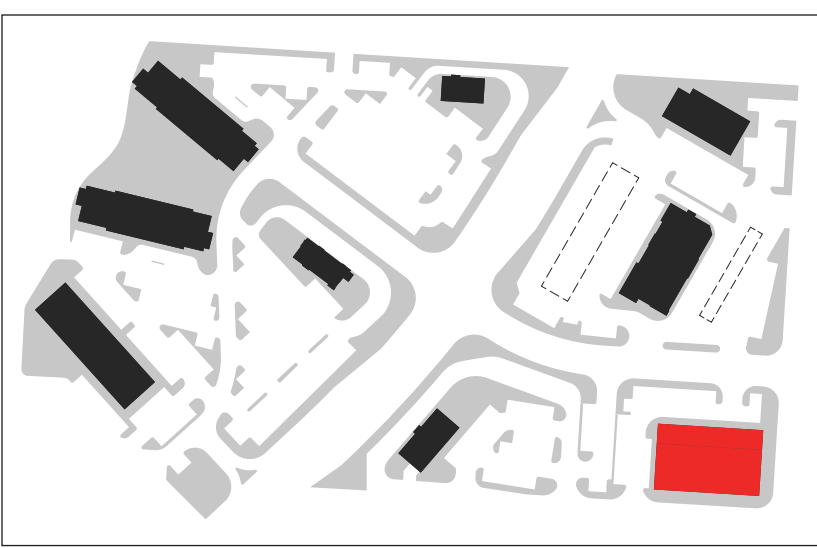



A - NORTH ELEVATION

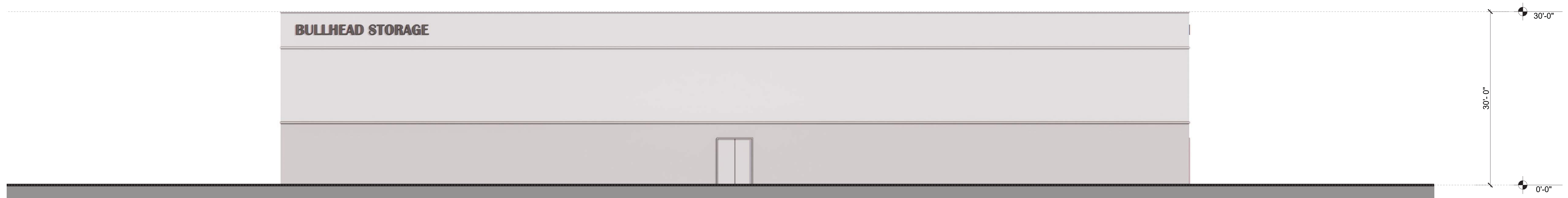

B - SOUTH ELEVATION

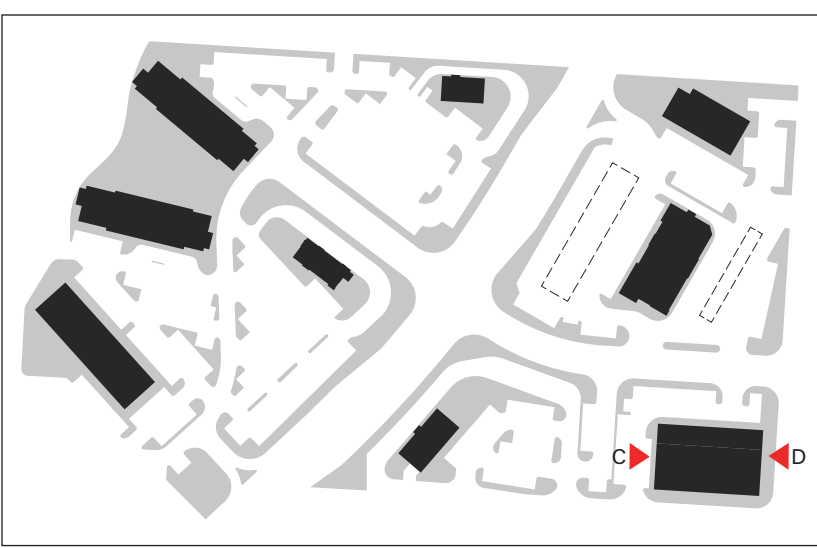

C - WEST ELEVATION

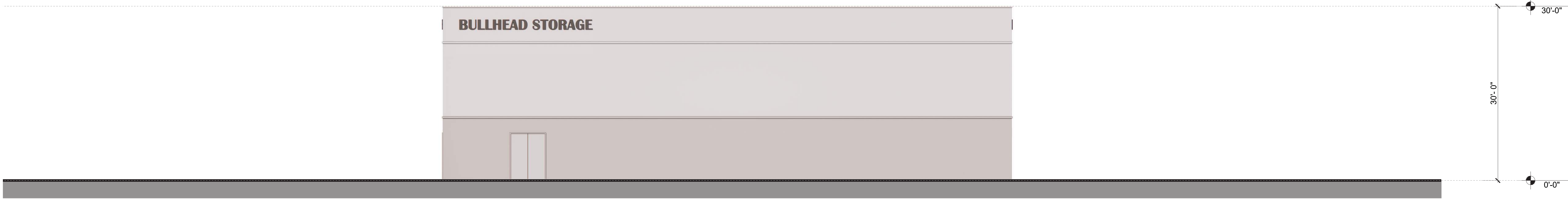

D - EAST ELEVATION

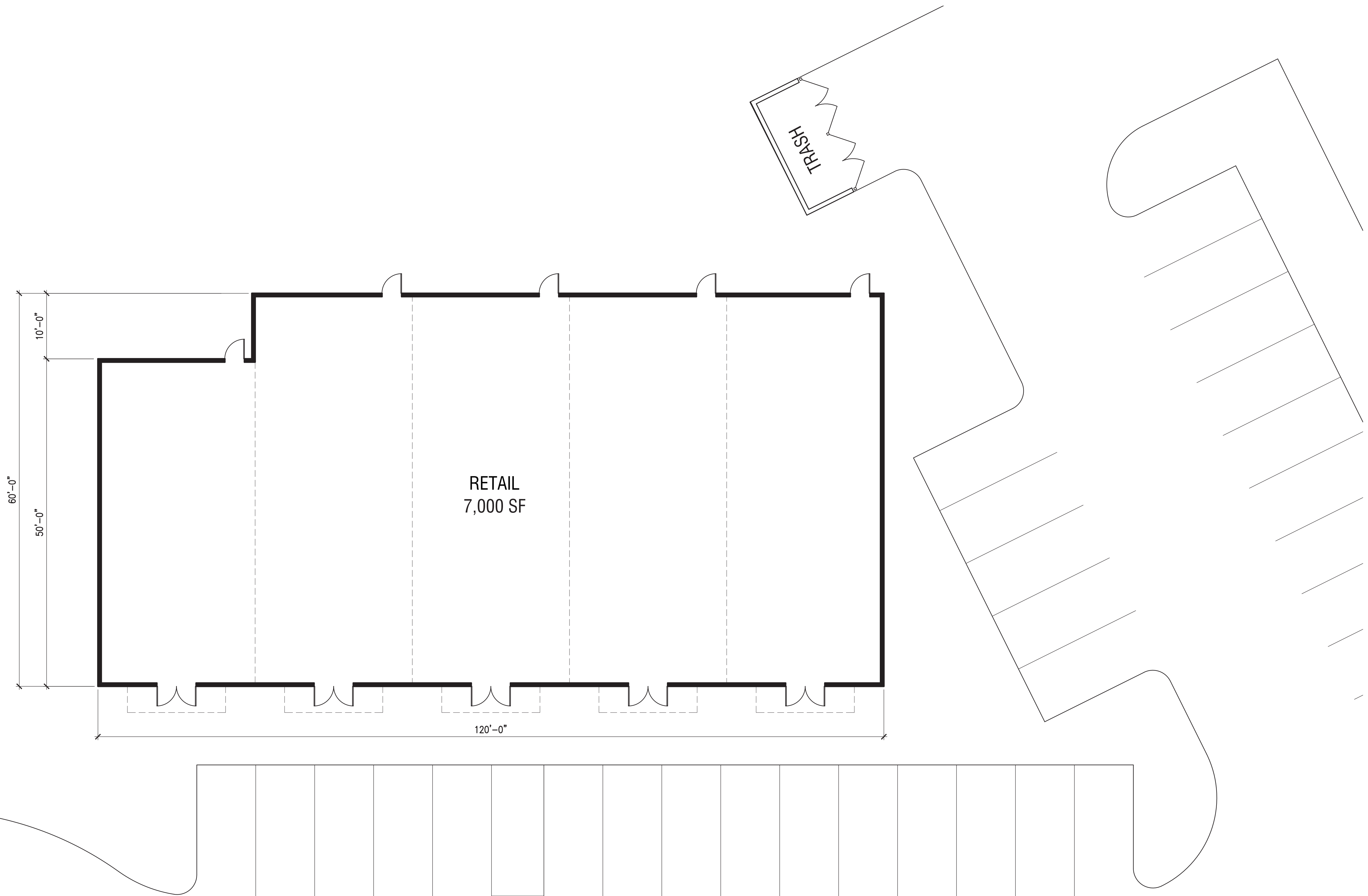
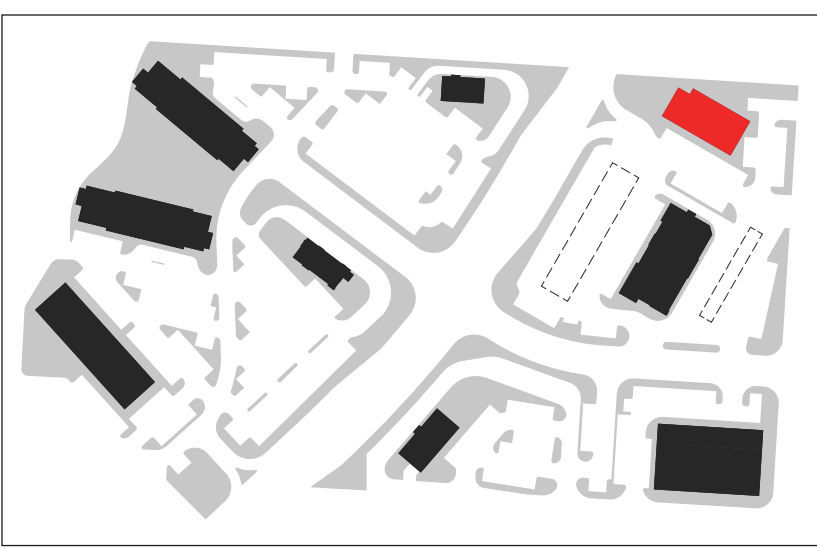

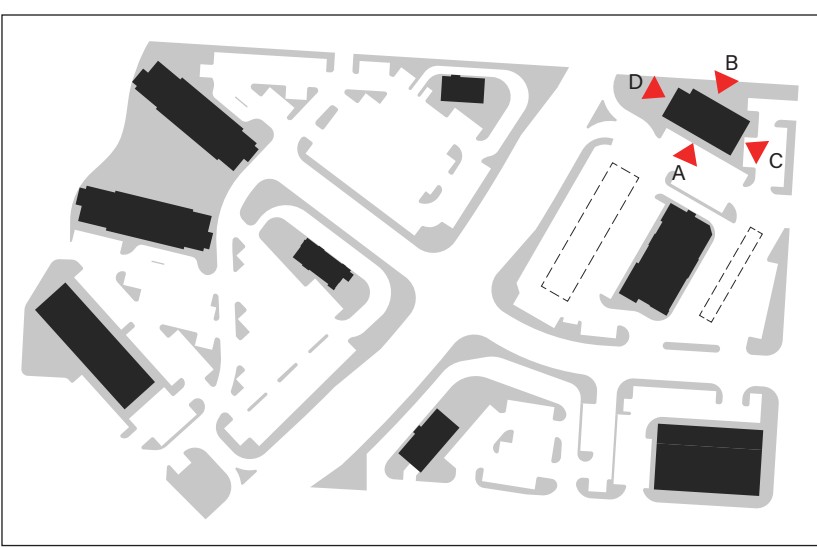

A - SOUTH ELEVATION



C - EAST ELEVATION

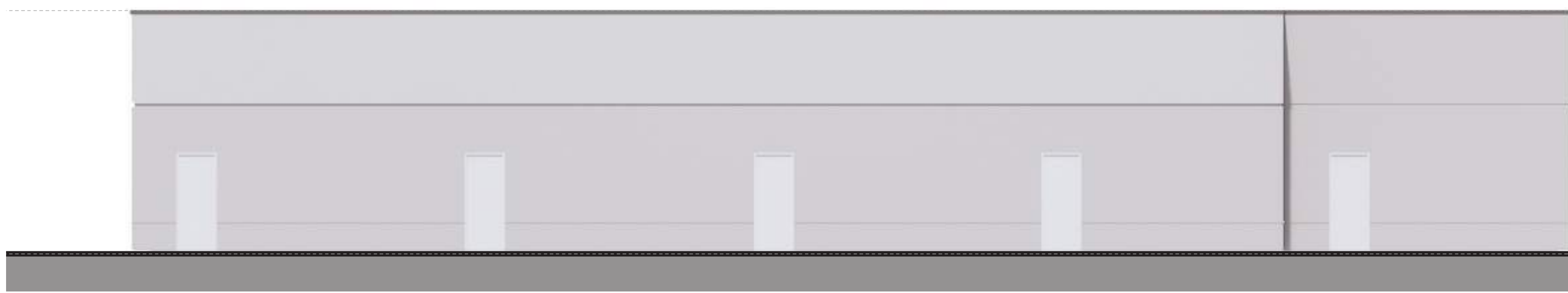
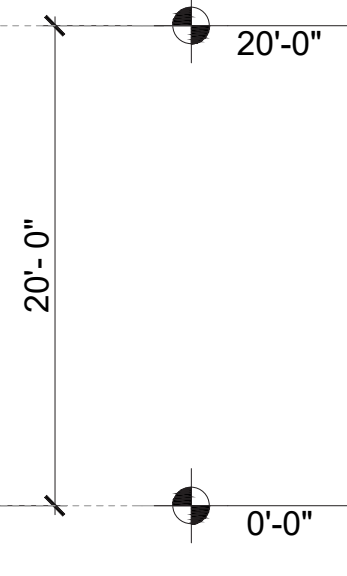

B - NORTH ELEVATION

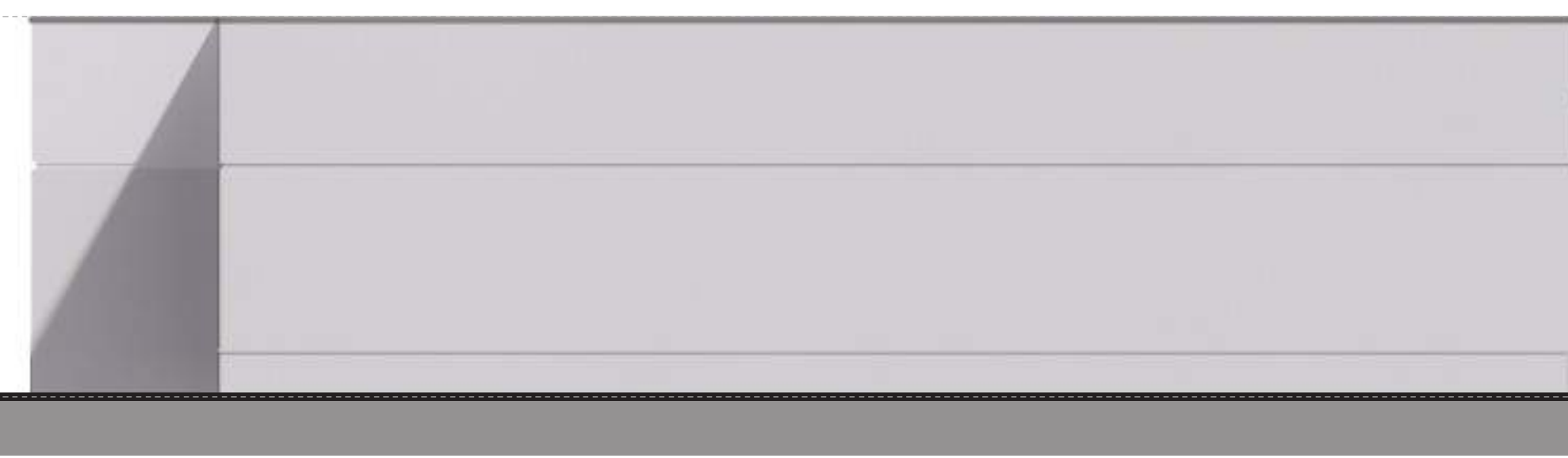

D - WEST ELEVATION

