

VICINITY MAP  
NOT TO SCALE

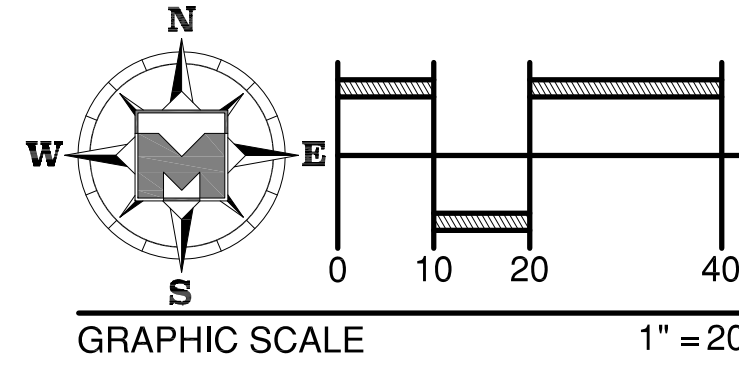

- NOTES:**
1. LANDS SHOWN HEREON ARE NOT ABSTRACTED FOR RIGHTS-OF-WAY, EASEMENTS, OWNERSHIP, OR OTHER INSTRUMENTS OF RECORD AND ARE SUBJECT TO ANY AND ALL EASEMENTS, RIGHTS OF WAY, OR RESTRICTIONS THAT MAY LEGALLY AFFECT THIS PROPERTY.
  2. BEARINGS SHOWN HEREON ARE BASED ON GRID NORTH AND TIE TO N.G.S MONUMENT WAS CALCULATED FROM G.P.S. OBSERVATIONS MADE USING SPECTRA PRECISION EPOCH 50 RECEIVER.
  3. UNDERGROUND FOUNDATIONS, LANDSCAPE FEATURES AND ROOF OVERHANGS WERE NOT LOCATED.
  4. THIS IS AN ABOVE GROUND SURVEY. THE SURVEYOR MAKES NO CERTIFICATION TO THE EXISTENCE OF UNDERGROUND UTILITIES OR STRUCTURES. CALL 811 BEFORE DIGGING..
  5. THERE WAS NO INVESTIGATION INTO THE EXISTENCE OF ENVIRONMENTALLY SENSITIVE AREAS.
  6. DUE TO VEGETATION, THERE MAY BE ADDITIONAL UTILITIES OR IMPROVEMENTS NOT VISIBLE AT THE TIME OF THE SURVEY THAT ARE NOT SHOWN .
  7. SOME FEATURES MAY BE EXAGGERATED FOR CLARITY.
  8. OWNERSHIP, DEED AND PLAT INFORMATION IS PER THE HENDERSON COUNTY GIS WEBSITE.
  9. THIS SURVEY IS OF AN EXISTING PARCEL OR PARCELS OF LAND AND DOES NOT CREATE A NEW STREET OR CHANGE AN EXISTING STREET.

- STANDARD LEGEND**
- PIN - PROPERTY IDENTIFICATION NUMBER
  - AC. - AIR CONDITIONER(HEAT PUMP)
  - W.P.P. - WOODEN POWER POLE
  - FIR/CAP - FOUND IRON ROD WITH PLASTIC CAP
  - TPA - TREE PROTECTION AREA
  - CH - CHORD LENGTH
  - CB - CHORD BEARING
  - R - RADIUS
  - D - DELTA ANGLE
  - O.E. - OVERHEAD ELECTRIC LINES
  - A.G. - ABOVE GROUND
  - B.G. - BELOW GROUND
  - I.P.F. - IRON PIN FOUND
  - SIR/CAP - SET IRON ROD & CAP
  - D.B. - DEED BOOK
  - P.B. - PLAT BOOK
  - PG. - PAGE
  - AC. - ACRES
  - U.E. - UTILITY EASEMENT
  - o.a. - OVERALL
  - CONC. - CONCRETE
  - CO. CLEANOUT
  - SAN - SANITARY
  - CLF - CHAIN LINK FENCE
  - S.F. - SQUARE FEET
  - F.H. - FIRE HYDRANT
  - FND. - FOUND
  - I.R. - IRON ROD (REBAR)
  - R/W - RIGHT-OF-WAY
  - MH - MANHOLE
  - WV - WATER VALVE
  - WM - WATER METER

**DESCRIPTION:** (PROPERTY SURVEYED) PIN 9528488595  
ALL OF THAT LAND AS DESCRIBED IN DEED BOOK 1018, PAGE 161  
OF THE PUBLIC RECORDS OF HENDERSON COUNTY, NORTH  
CAROLINA.

SAID LANDS CONTAINING 29,992 SQ.FT / 0.689 ACRES

**Boundary Survey**  
For : Liam Moore and Charlie Abrams  
MILLS RIVER TOWNSHIP, HENDERSON COUNTY, NORTH CAROLINA

**THOMAS MULLOY P.L.S.**  
140 Macedonia Rd. Asheville, NC. 28804  
(828) 337-2253 mulloyssurveying.com

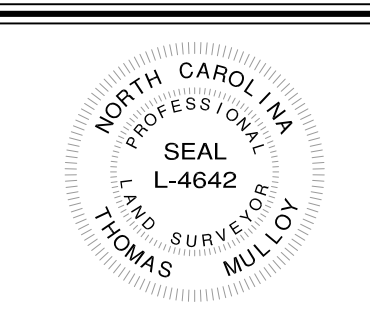

CURRENT OWNER:  
FRONTIER HOLDINGS LLC

File no: 2521

**SURVEYORS CERTIFICATE:**

I THOMAS MULLOY, CERTIFY THAT THIS PLAT WAS DRAWN UNDER MY SUPERVISION FROM AN ACTUAL FIELD SURVEY MADE UNDER MY SUPERVISION ON DECEMBER 20, 2021 OF DB 1018, PG 161, THAT THE BOUNDARIES NOT SURVEYED ARE CLEARLY INDICATED; THAT THE RATIO OF PRECISION AS CALCULATED IS AT LEAST 1:10,000; THAT THIS PLAT WAS PREPARED IN ACCORDANCE WITH G.S. 47-30 AS AMENDED. WITNESS MY ORIGINAL SIGNATURE, REGISTRATION NUMBER AND SEAL THIS 22nd DAY OF DECEMBER, 2021.

*Thomas M. Mulloy*  
THOMAS M. MULLOY, P.L.S.  
PLS #4642 State of NC.  
Bus. Lic. P-0845