

Retail/Office Space For Lease



1269 Broadway
El Cajon, CA 92021

FOR LEASE



1269 Broadway El Cajon



BEN AMEEN

Broker
(619) 840-6692
bensdcommercial@gmail.com
BRE# 01999481

KW COMMERCIAL

810 Jamacha Rd. Suite 102
El Cajon, CA 92019

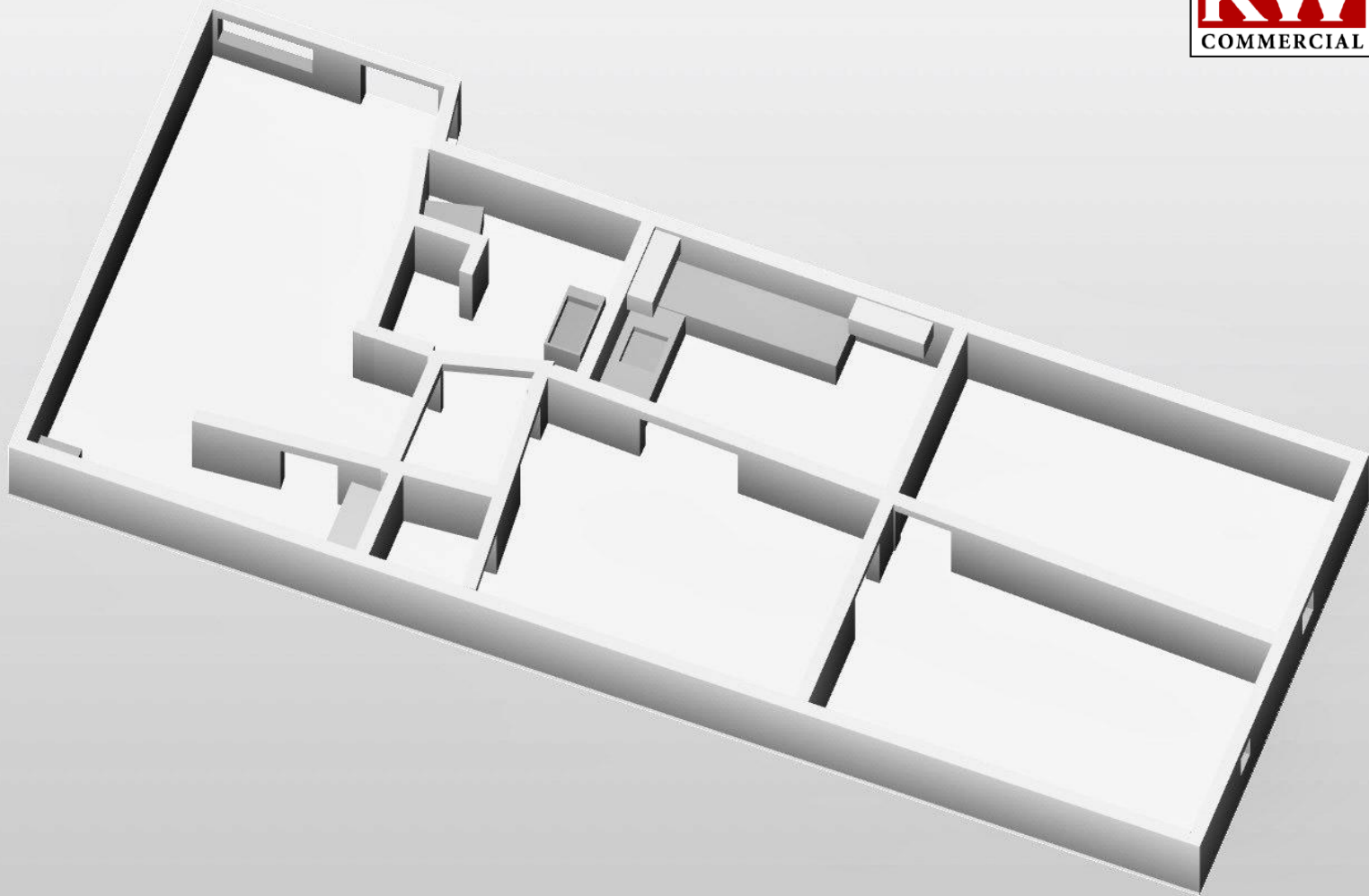

SUMMARY

LEASE RATE: \$2.61/SF Gross

SUITE SF: 765 SF

LOT SIZE: 13,951 SF

PARKING: Shared

PROPERTY OVERVIEW

- Retail/Office space for lease in a well-established convenient location. Close to busiest section for retail and businesses on Broadway. Recently remodeled for quick move-in.
- Excellent Exposure to Broadway
- The space includes a kitchen and a shower
- Outdoor Retail Area
- Traffic Count: 22,526

KW COMMERCIAL

810 Jamacha Rd. Suite102
El Cajon, California 92019



BEN AMEEN

Broker

(619) 840-6692

bensdcommercial@gmail.com

BRE# 01999481

SUITE PHOTOS

1269 Broadway El Cajon, CA 92021



SUITE FLOORPLAN

1269 Broadway El Cajon, CA 92021

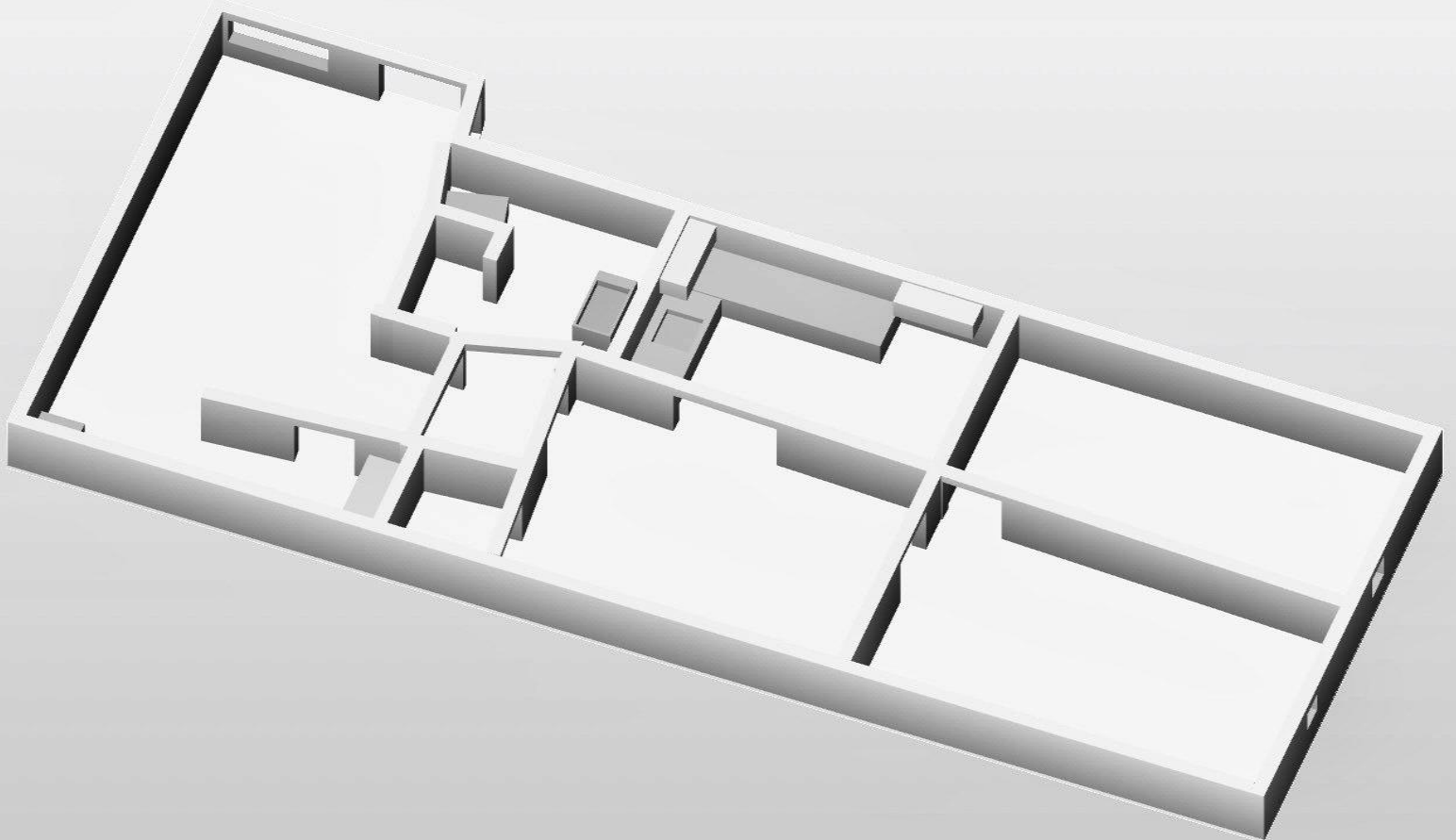
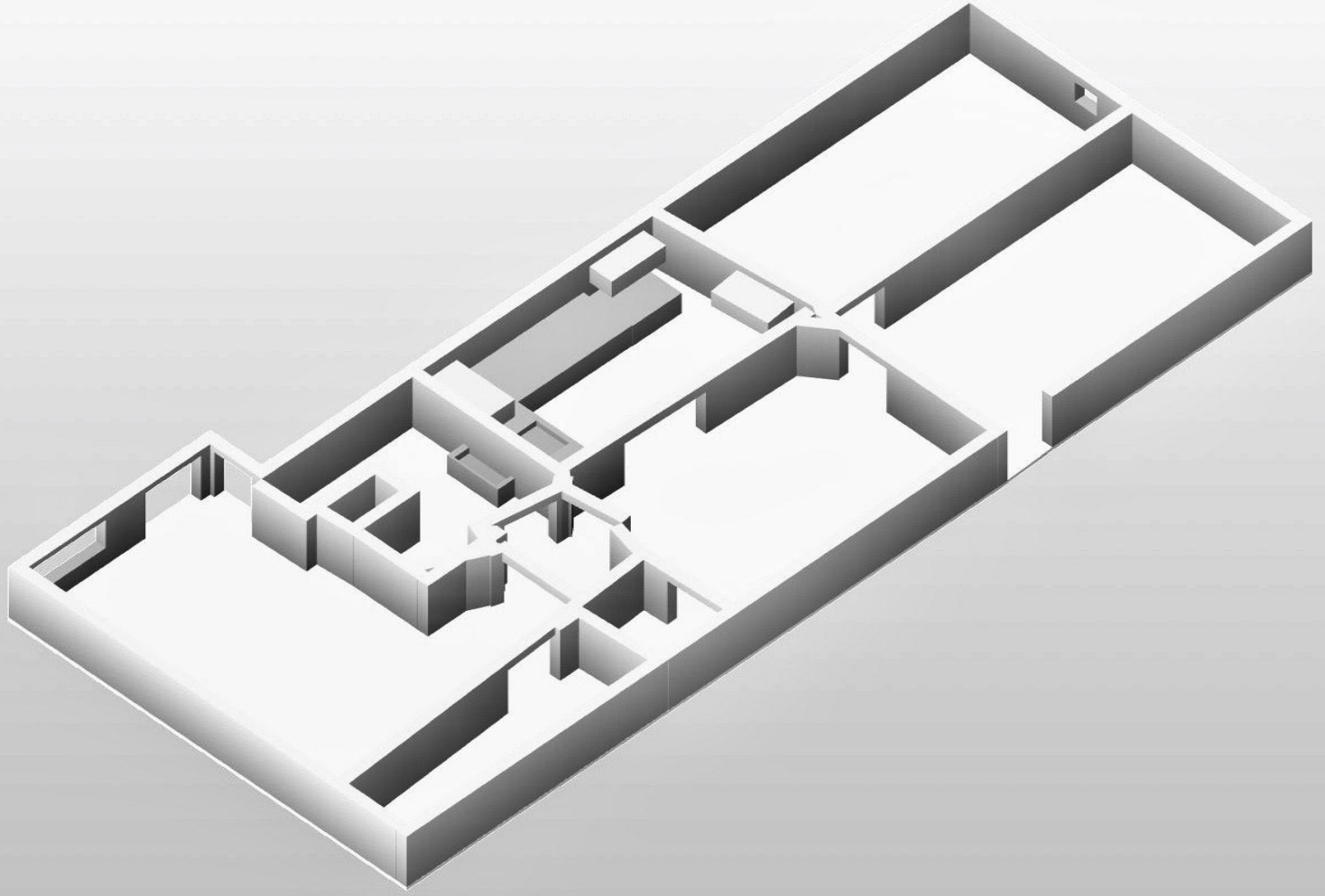

LOCATION MAPS

1269 Broadway El Cajon, CA 92021

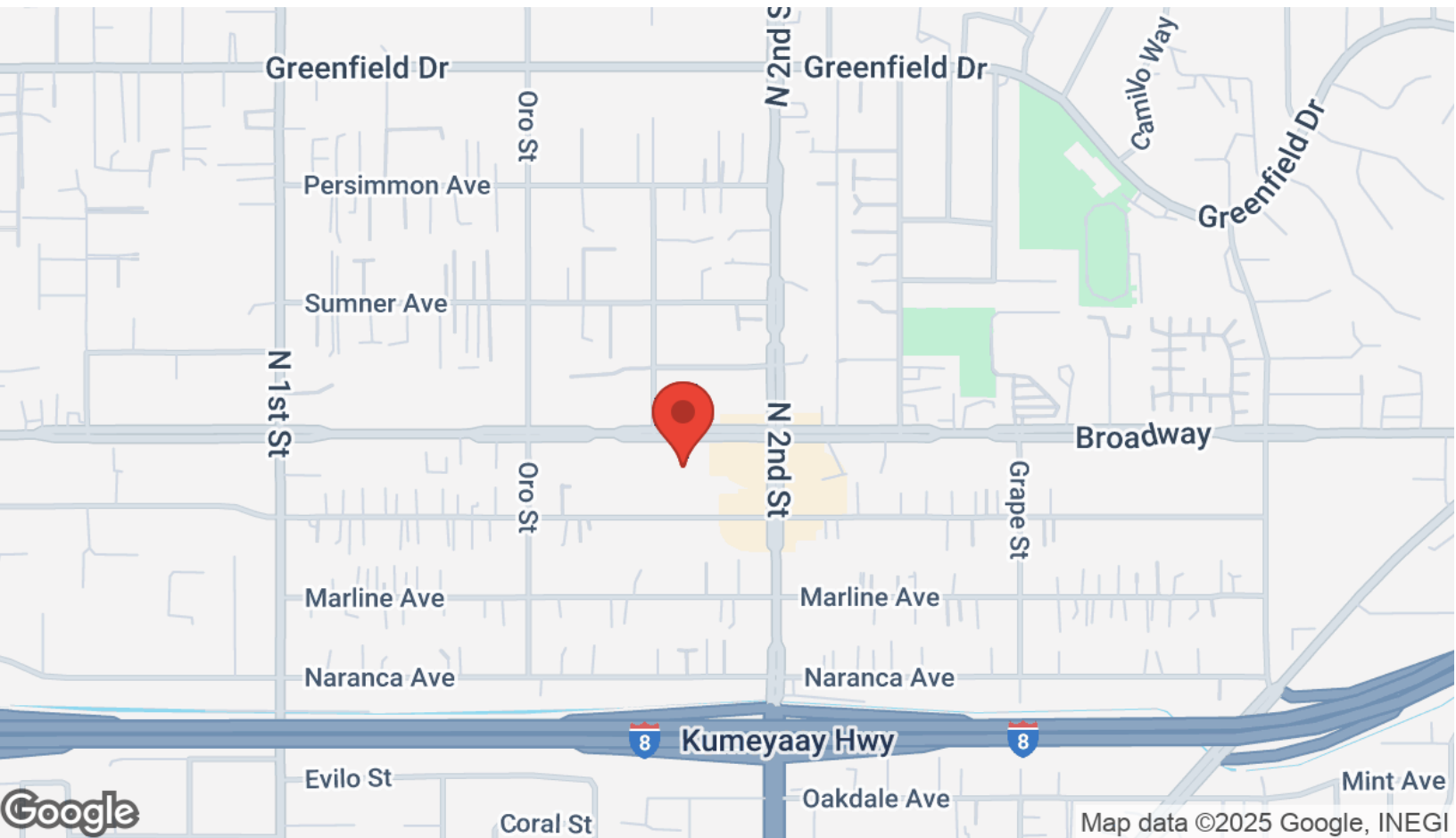
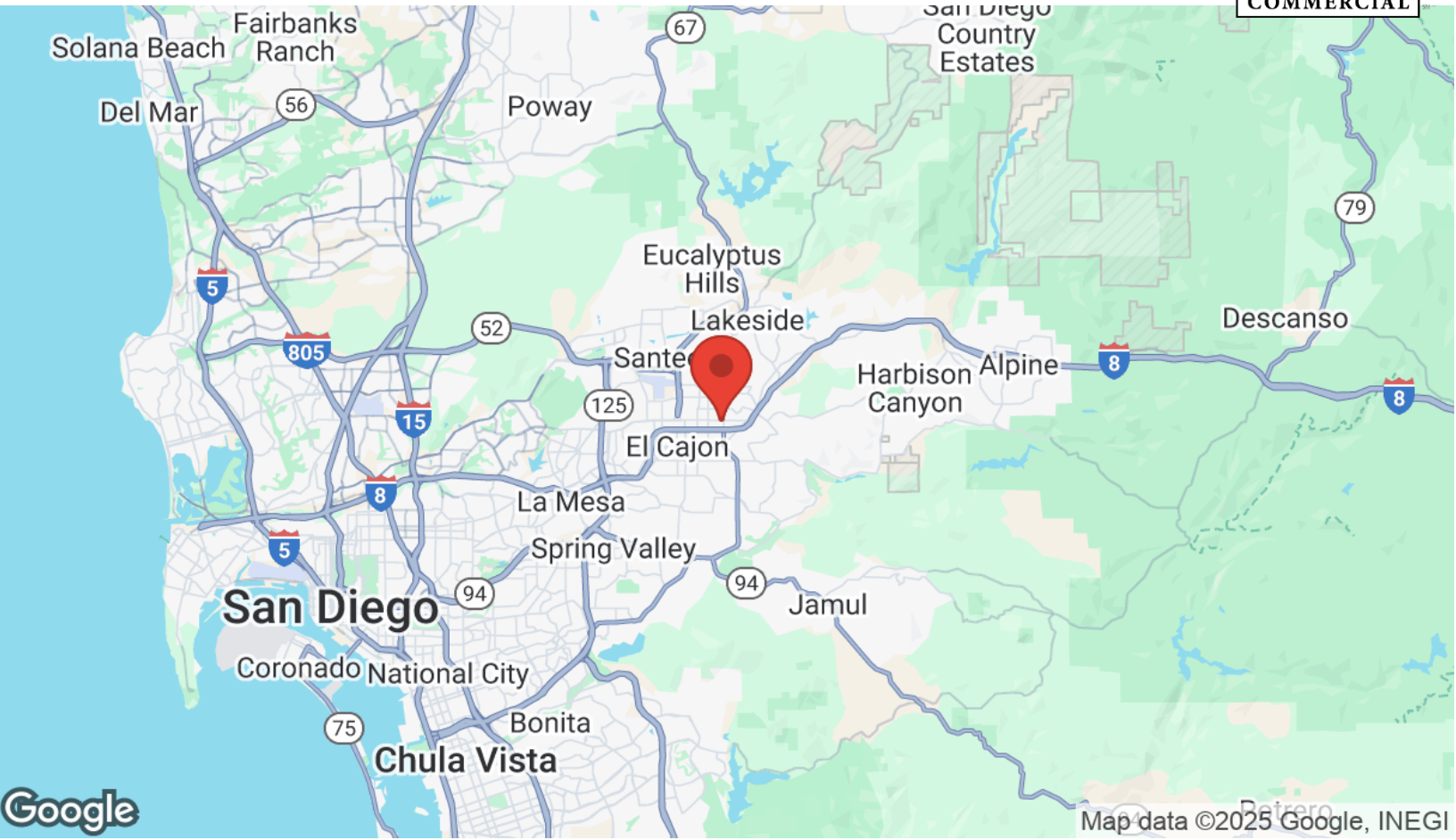

AERIAL MAP

1269 Broadway El Cajon, CA 92021



Google

Imagery ©2025 Airbus, Maxar Technologies, Vexcel Imaging US, Inc.

DEMOGRAPHICS

1269 Broadway El Cajon, CA 92021

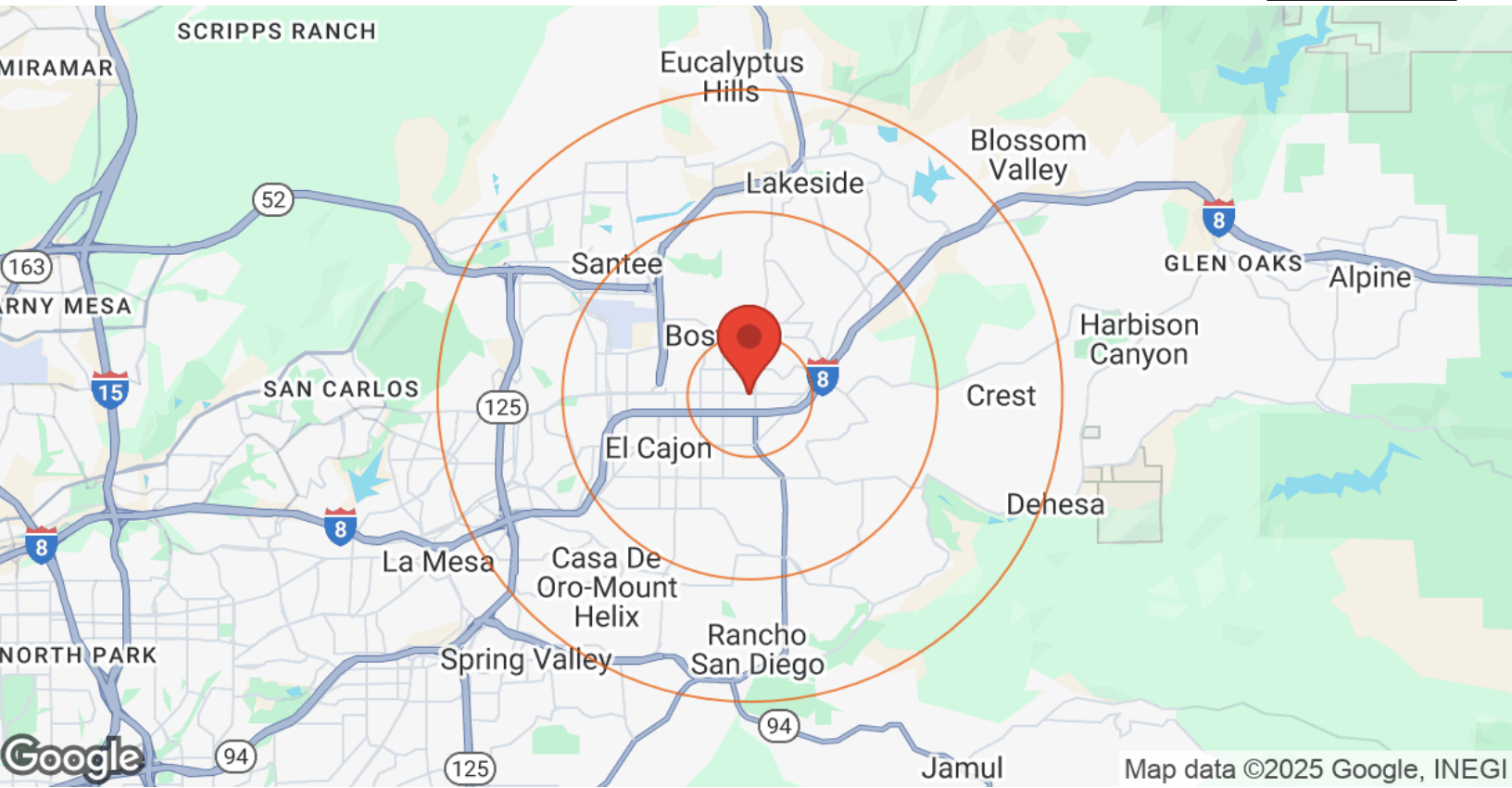

Category	Sub-category	1 Mile	3 Miles	5 Miles
Population	Male	16,650	74,723	143,654
	Female	16,303	74,751	144,787
	Total Population	32,953	149,473	288,441
Age	Ages 0-14	6,663	29,145	53,764
	Ages 15-24	4,079	17,315	32,019
	Ages 25-54	13,461	59,850	114,689
	Ages 55-64	3,959	18,207	36,057
	Ages 65+	4,789	24,956	51,913
Race	White	15,445	76,844	157,229
	Black	2,514	9,492	15,807
	Am In/AK Nat	86	404	779
	Hawaiian	92	433	865
	Hispanic	11,013	45,679	80,850
	Asian	2,458	10,388	20,306
	Multi-Racial	1,298	5,800	11,682
	Other	46	433	952
Income	Median	\$67,819	\$85,976	\$99,520
	< \$15,000	1,102	3,809	6,070
	\$15,000-\$24,999	986	3,174	5,258
	\$25,000-\$34,999	581	2,742	4,821
	\$35,000-\$49,999	1,484	5,298	8,711
	\$50,000-\$74,999	1,784	7,540	13,813
	\$75,000-\$99,999	1,505	6,598	12,567
	\$100,000-\$149,999	1,349	8,390	18,554
	\$150,000-\$199,999	922	5,781	13,696
> \$200,000	1,237	7,589	18,509	
Housing	Total Units	11,638	54,246	108,684
	Occupied	10,951	50,920	101,999
	Owner Occupied	3,766	23,521	56,899
	Renter Occupied	7,185	27,399	45,100
	Vacant	687	3,325	6,686