



OFFICE BUILDING

365 Rt. 59, AIRMONT NY, 10952



BUILDING INFORMATION

SCOPE OF WORK
NEW CONSTRUCTION OF 2 STORY COMMERCIAL OFFICE BUILDING ABOVE PARKING

BUILDING CLASSIFICATION STATEMENT PER BC107.4

ADDRESS: 365 RT. 59, AIRMONT NY, 10952

CROSS STREETS:

BLOCK:

LOT:

COMMUNITY DISTRICT:

ZONING MAP:

ZONING DISTRICT:

CONSTRUCTION TYPE: 1B

STRUCTURAL OCCUPANCY II (BUILDINGS EXCEPT THOSE LISTED IN CATEGORIES I, III, IV)
RISK CATEGORY PER TABLE 1604.5

FIRE PROTECTION: FULLY SPRINKLED

OCCUPANCY GROUPS: B (BUSINESS)

SITE IS NOT WITHIN 200' OF TRANSIT AUTHORITY AND IS LOCATED IN A FLOOD ZONE.

FLOOD ZONE

APPLICABLE BUILDING CODE 2020 NYS BUILDING CODE

THE PROJECT DOES NOT INCLUDE MODULAR CONSTRUCTION

ZBA NO. 323 VARIANCE RECEIVED;

(I) 36' FOR BUILDING HEIGHT, AND; (II) 177 PROPOSED & 34 LAND BANKED TO BE BUILT UPON APPROVAL BY DOT.

ARCH - DRAWING LIST

Sheet Number	Sheet Name
T	
T100	COVER
A	
A004	AREA PLAN
A101	1ST FLOOR
A102	2ND FLOOR
A103	3RD FLOOR
A200	ELEVATIONS
A201	ELEVATIONS
A300	SECTIONS
A301	SECTIONS
A800	3D AXON PLAN

APPLICABLE CODES

BUILDING CODE:	2020 NYS BUILDING CODE
(Applicable to all structural plans)	
MECHANICAL CODE:	2020 NYS MECHANICAL CODE
PLUMBING CODE:	2020 NYS PLUMBING CODE
ELECTRICAL CODE:	2020 NYS ELECTRICAL CODE
FUEL AND GAS CODE:	2020 NYS FUEL AND GAS CODE
BARRIER FREE:	ICC/ANSI A117.1-2009
FIRE CODE:	2020 NTC FIRE CODE
ENERGY CODE:	2020 NYS ENERGY CONSERVATION CODE

LL 1/11 'AMENDED 2010 NY STATE CODE'
ICC/AND117.1-2009-LL141/14
RODENT PROOFING: APPENDIX F OF NYC BUILDING CODE

ARCHITECT'S STATEMENT

TO THE BEST OF MY KNOWLEDGE, BELIEF AND PROFESSIONAL JUDGEMENT, THESE PLANS AND SPECIFICATIONS ARE IN COMPLIANCE WITH 2020 NYCECC, THE NEW YORK CITY ENERGY CONSERVATION CODE OF 2020, 1 RCNY §5000-01, AND WITH SECTION 28-104.7.1 OF THE N.Y.C. ADMINISTRATIVE CODE.

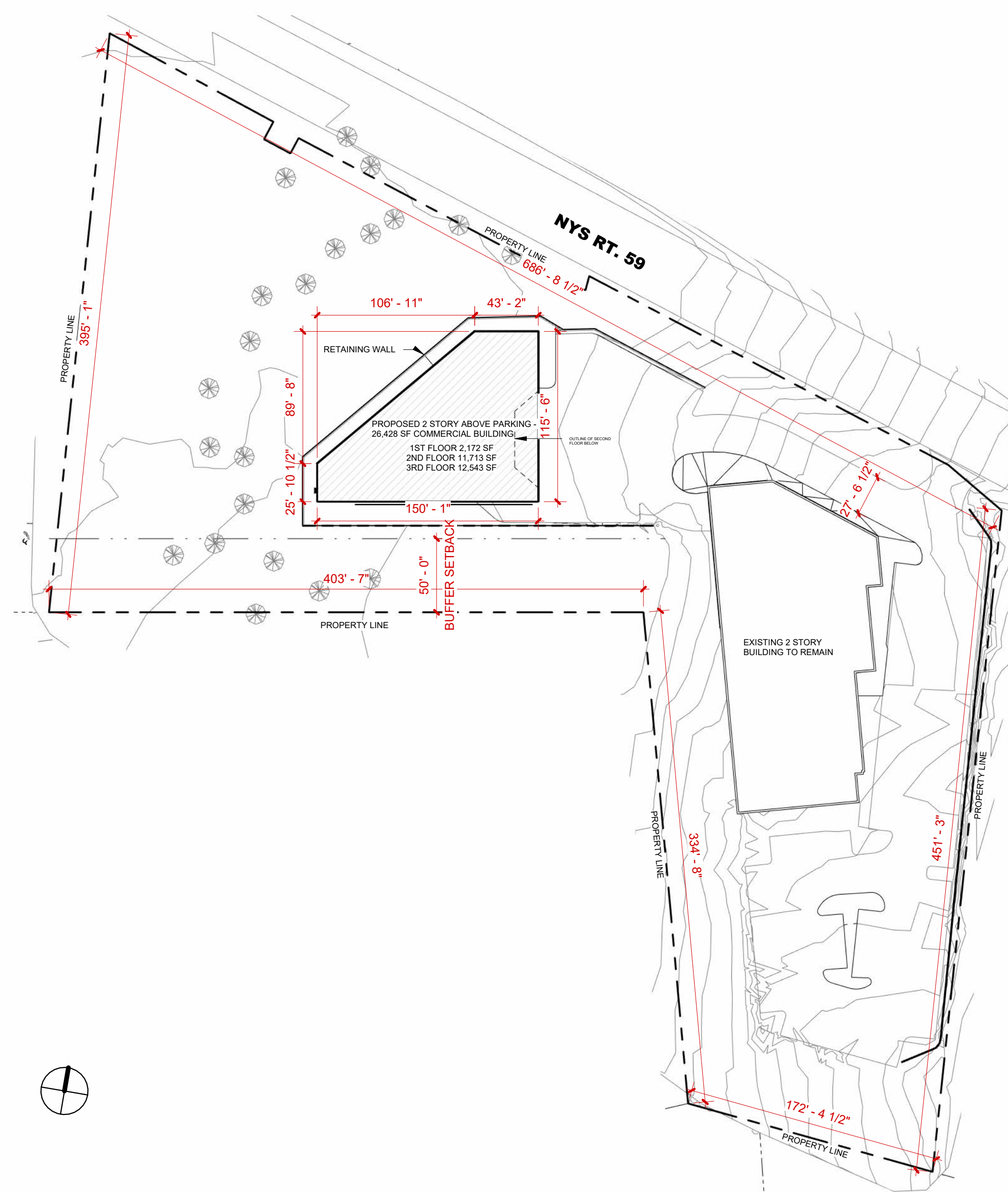

1 PLOT PLAN
1/64" = 1'-0"

DESIGN

BILD
ARCHITECTURE

BILD ARCHITECTURE

501 Chestnut Ridge RD
Suite 301
Chestnut Ridge, NY 10977
Tel 212.381.0670
info@bildny.com

CONSULTING ENGINEERS

CIVILTEC

139 Lafayette Avenue
2nd Floor
Suffern, NY 10901
P 845.547.2241

Description	Date

Revisions

Seal & Signature



CLIENT

MARK HERTZ

PROJECT NAME

OFFICE BUILDING

PROJECT LOCATION

365 Rt. 59, AIRMONT NY, 10952

JOB #: Q08050448

FILING # 11

PROJECT NUMBER

22077

DRAWN BY

REVIEWED BY

SW

DATE:

06/29/22

DRAWING TITLE

COVER

T100

Scale
1/64" = 1'-0"

OFFICE BUILDING

365 Rt. 59, AIRMONT NY, 10952



DESIGN

BILD
ARCHITECTURE

BILD ARCHITECTURE

501 Chestnut Ridge RD
Suite 301
Chestnut Ridge, NY 10977
Tel 212.381.0670
info@bildny.com

CONSULTING ENGINEERS

CIVILTEC
139 Lafayette Avenue
2nd Floor
Suffern, NY 10901
P 845.547.2241

Description	Date

Revisions

Seal & Signature



CLIENT

MARK HERTZ

PROJECT NAME

OFFICE BUILDING

PROJECT LOCATION

365 Rt. 59, AIRMONT NY, 10952

JOB #:
FILING #

Q08050448
11

PROJECT NUMBER

22077

DRAWN BY

Author

REVIEWED BY

Checker

DATE:

05/29/24

DRAWING TITLE

ARC 1

ARC1

Scale



3 South Copy 1
3/32" = 1'-0"



1 East ARB
3/32" = 1'-0"



2 North Copy 1
3/32" = 1'-0"

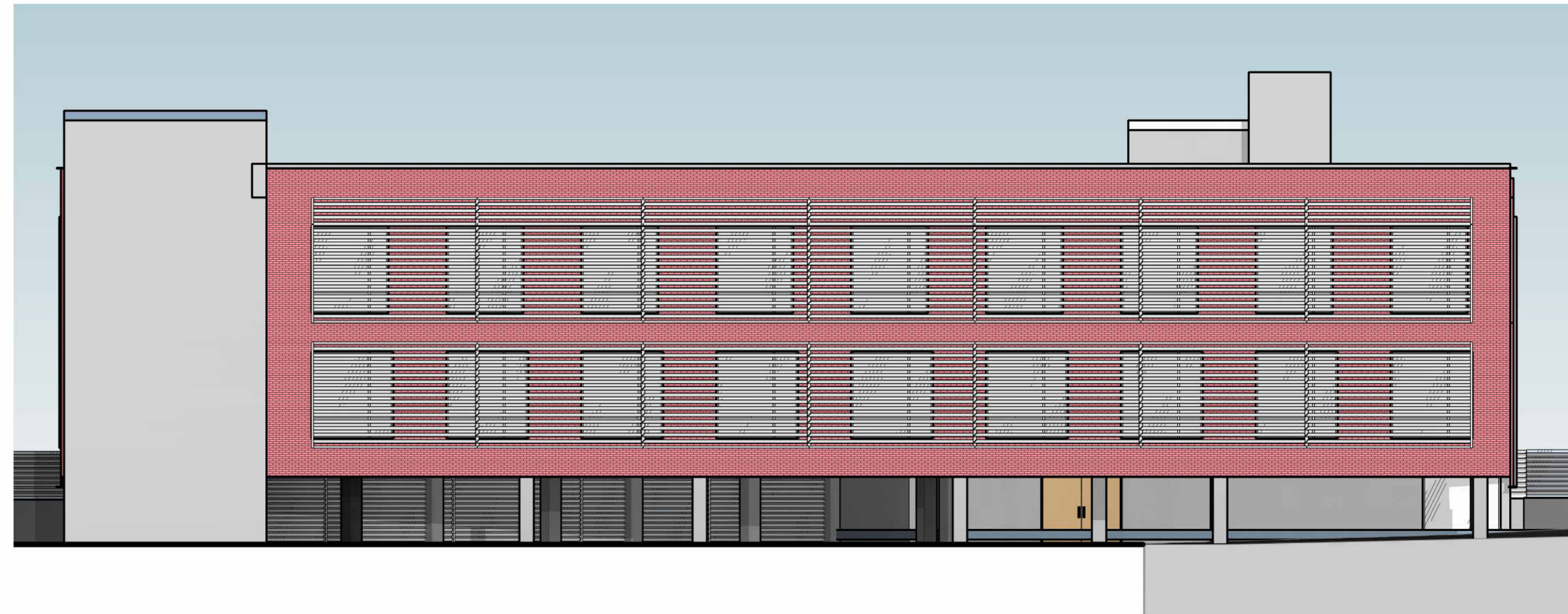

4 West Copy 1
3/32" = 1'-0"

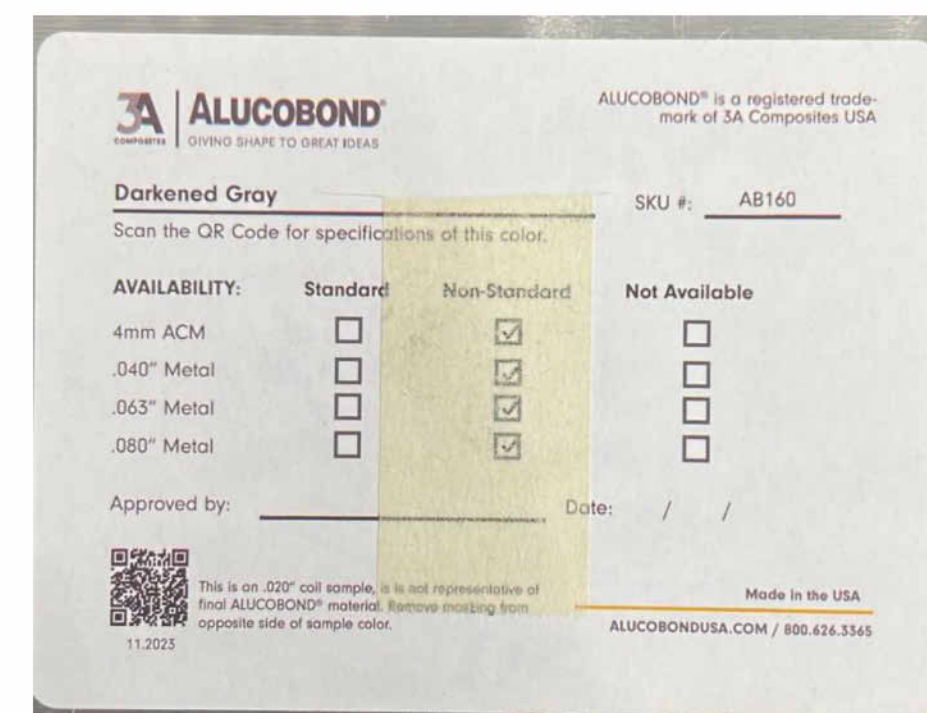

DESIGN



BILD ARCHITECTURE

501 Chestnut Ridge RD
Suite 301
Chestnut Ridge, NY 10977
Tel 212.381.0670
info@bildny.com

CONSULTING ENGINEERS

CIVILTEC

139 Lafayette Avenue
2nd Floor
Suffern, NY 10901
P 845.547.2241

Description	Date

Revisions

Seal & Signature



CLIENT

MARK HERTZ

PROJECT NAME

OFFICE BUILDING

PROJECT LOCATION

365 Rt. 59, AIRMONT NY, 10952

JOB #:

Q08050448

FILING #

11

PROJECT NUMBER

22077

DRAWN BY

REVIEWED BY

Author

Checker

DATE:

05/29/24

DRAWING TITLE

ARC 2

ARC 2

Scale
3/32" = 1'-0"

VIEW FROM ROUTE 59

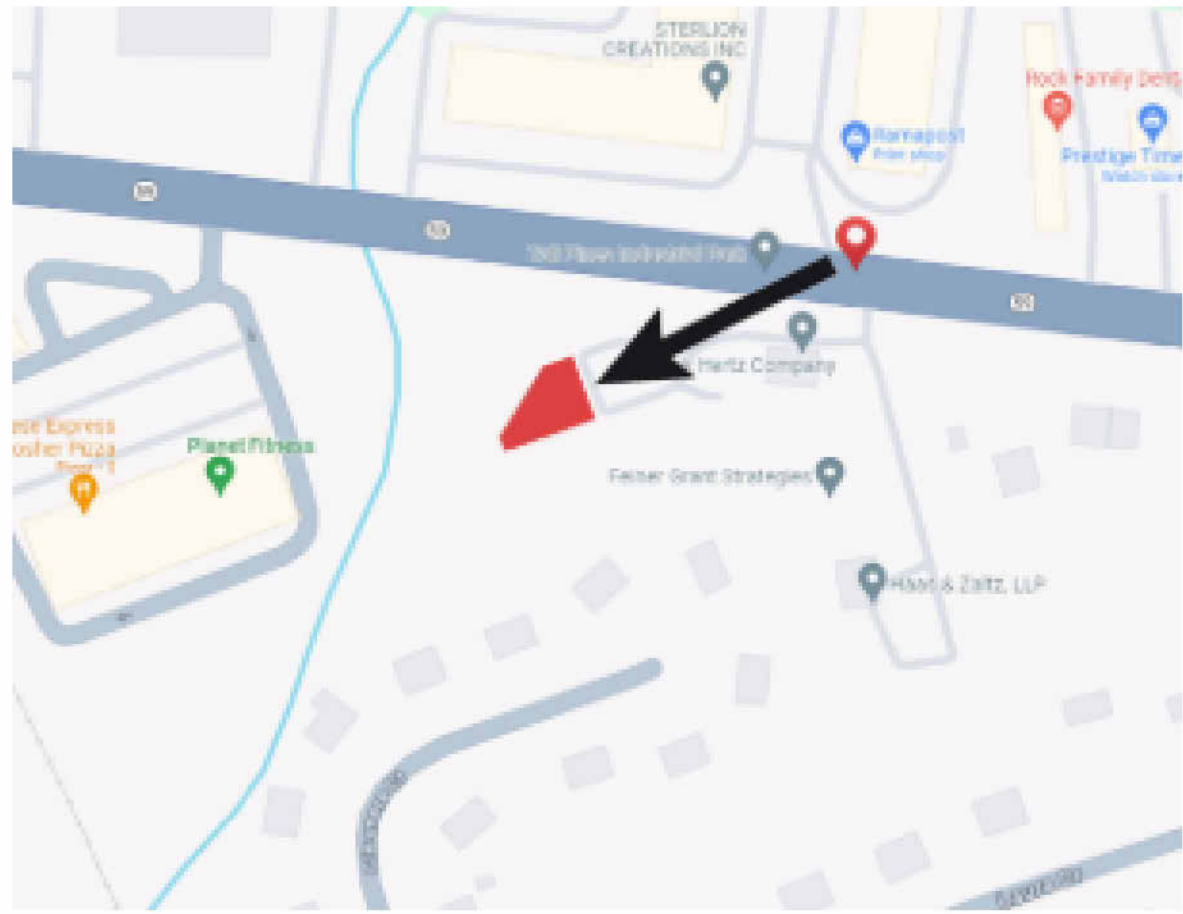

VIEW FROM GLENMERE CT.

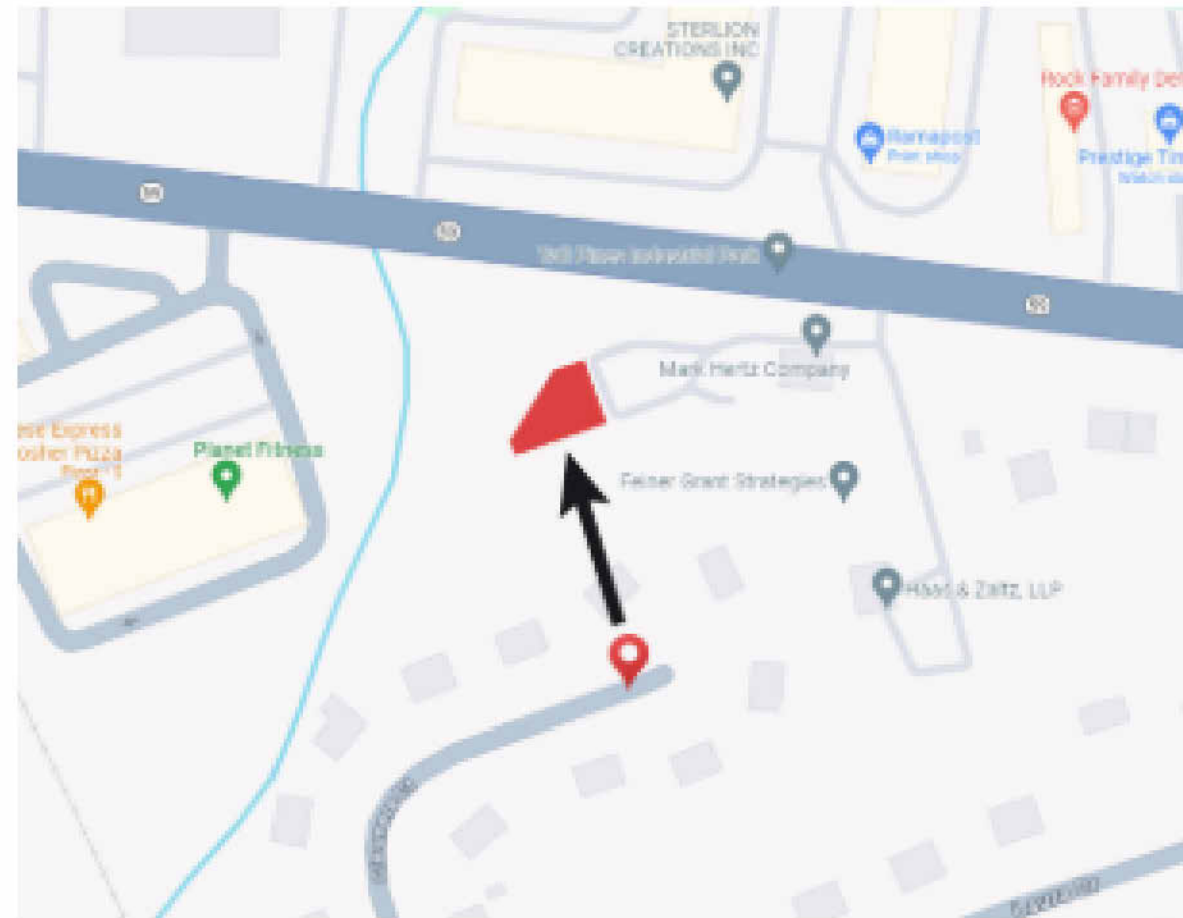

NO SPRUCE PINE TREES



WITH SPRUCE PINE TREES



DESIGN



BILD ARCHITECTURE

501 Chestnut Ridge RD
Suite 301
Chestnut Ridge, NY 10977
Tel 212.381.0670
info@bildny.com

CONSULTING ENGINEERS

CIVILTEC

139 Lafayette Avenue
2nd Floor
Suffern, NY 10901
P 845.547.2241

Description	Date

Revisions

Seal & Signiture



CLIENT

MARK HERTZ

PROJECT NAME

OFFICE BUILDING

PROJECT LOCATION

365 Rt. 59, AIRMONT NY, 10952

JOB #:

Q08050448

FILING #

11

PROJECT NUMBER

22077

DRAWN BY

Author

REVIEWED BY

Checker

DATE:

06/29/22

DRAWING TITLE

VISUAL ANALYSIS

A001

Scale

A B C D E F G H I J K L M N O P

1
2
3
4
5
6
7
8
9
10
11
12
13
14
15
16

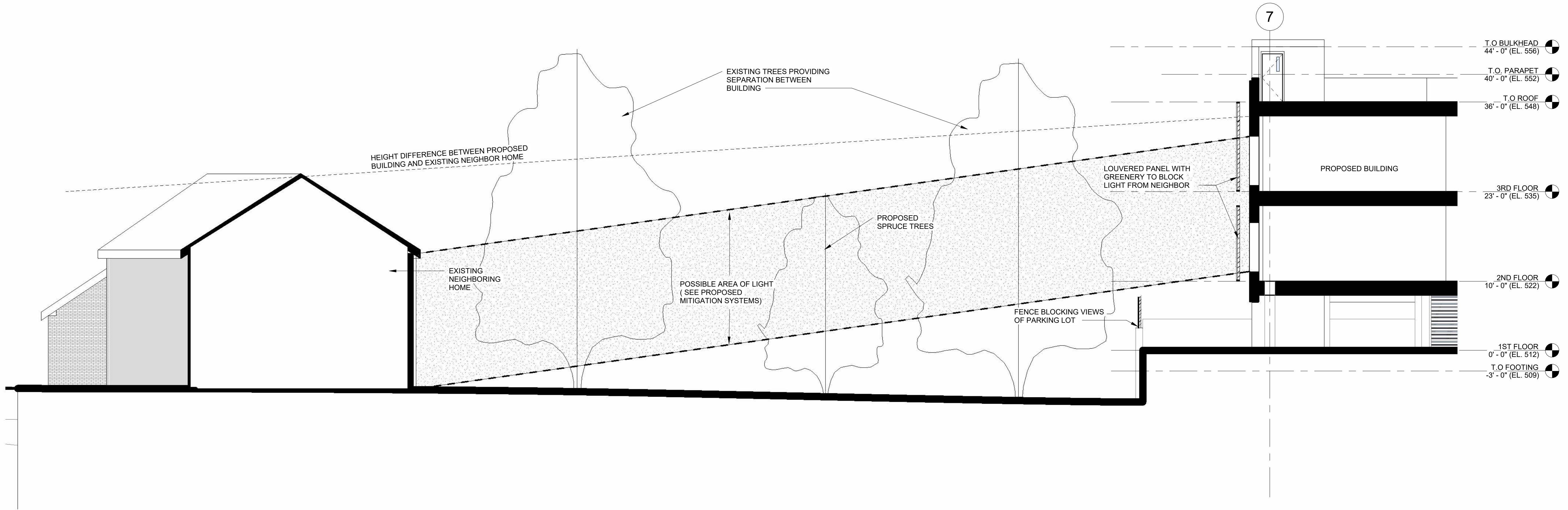

1 Section 4
1/8" = 1'-0"

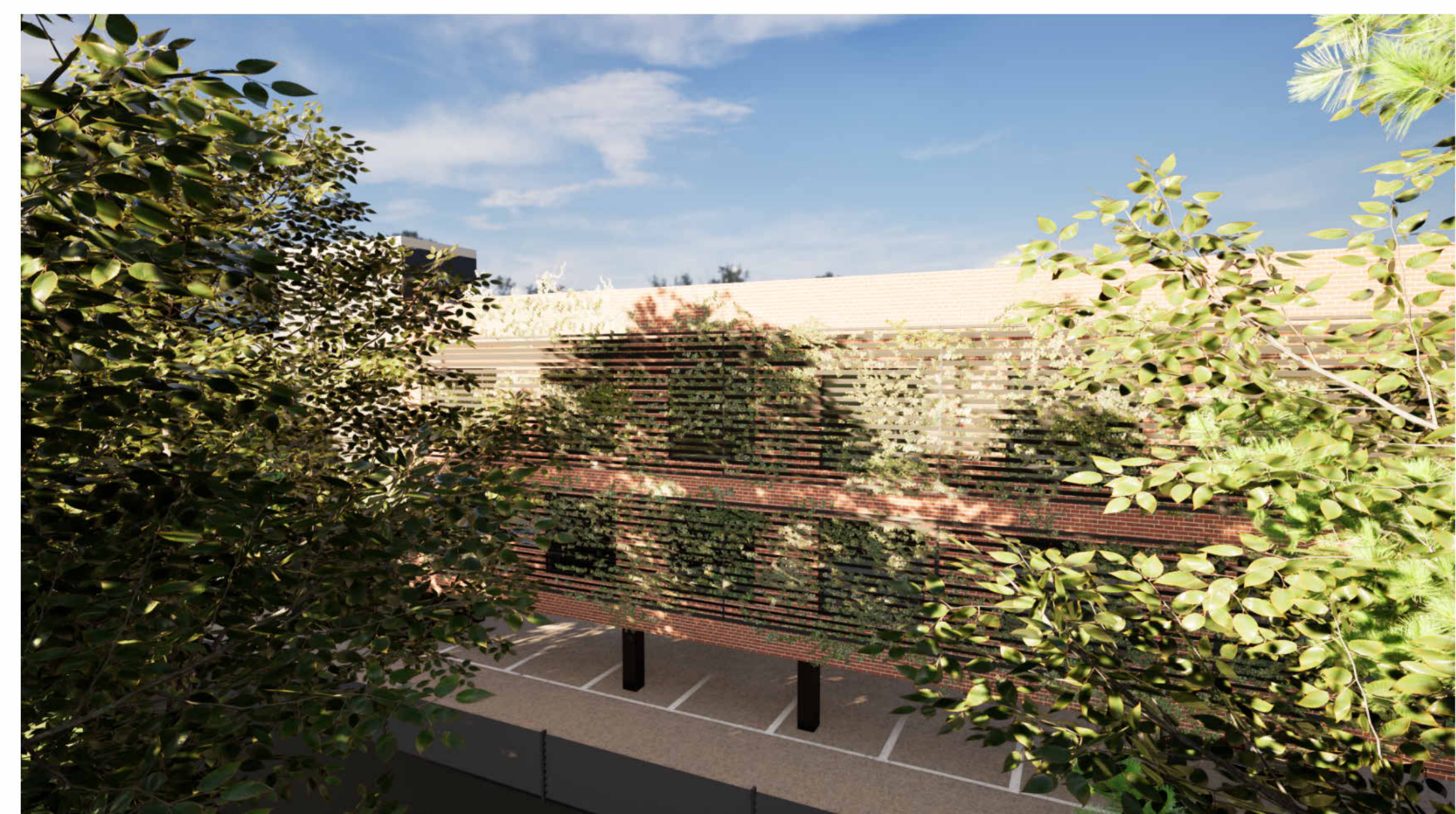
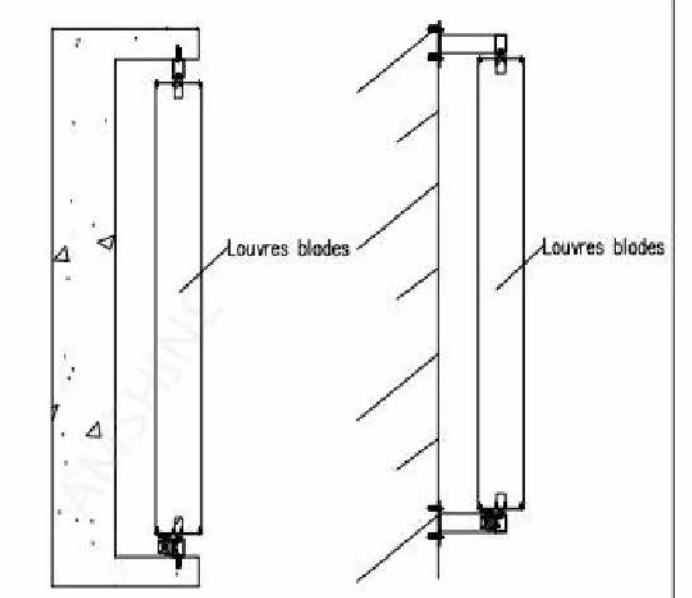
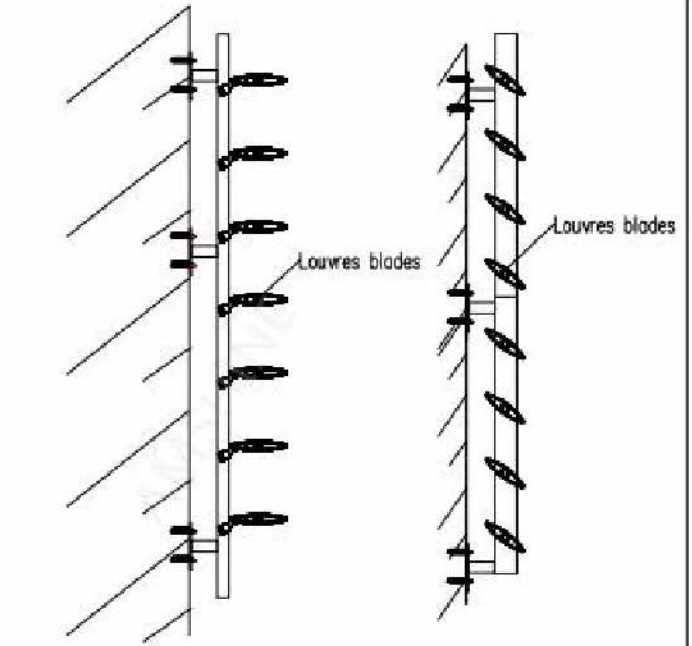

IMAGE SHOWING THE GREEN WALL SYSTEM

LOUVERED SYSTEM



Fixed or Adjust Louvres Mounting to Wall



Fixed Louvres Mounting to Building

DESIGN



BILD ARCHITECTURE

501 Chestnut Ridge RD
Suite 301
Chestnut Ridge, NY 10977
Tel 212.381.0670
info@bildny.com

CONSULTING ENGINEERS

CIVILTEC
139 Lafayette Avenue
2nd Floor
Suffern, NY 10901
P 845.547.2241

Description	Date

Revisions

Seal & Signature



CLIENT

MARK HERTZ

PROJECT NAME

OFFICE BUILDING

PROJECT LOCATION

365 Rt. 59, AIRMONT NY, 10952

JOB #:
FILING #

Q08050448
11

PROJECT NUMBER

22077

DRAWN BY

Author

REVIEWED BY

Checker

DATE:

06/29/22

DRAWING TITLE

VISUAL ANALYSIS 2

A001.1

Scale
1/8" = 1'-0"

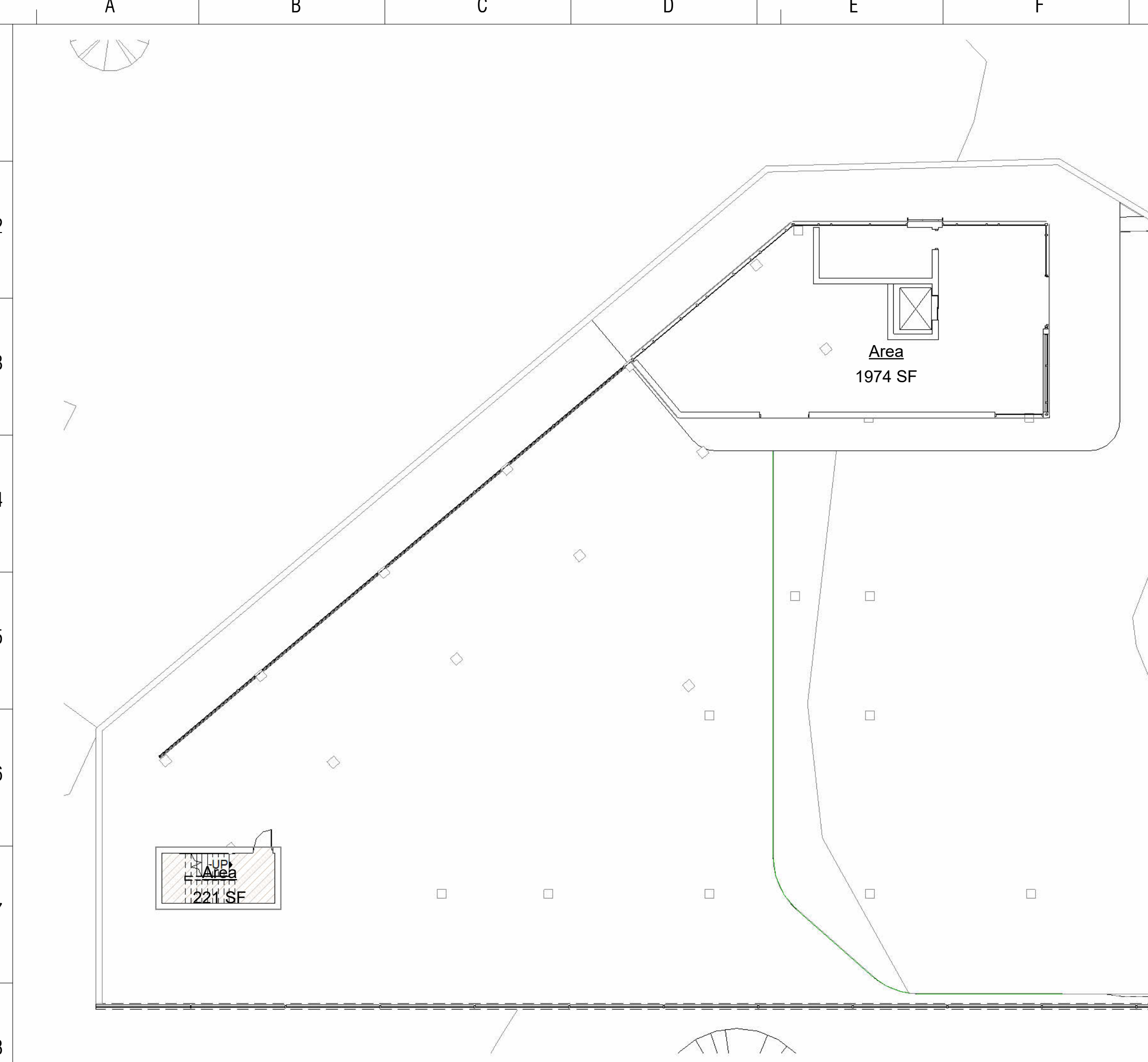

1 1ST FLOOR
1/16" = 1'-0"

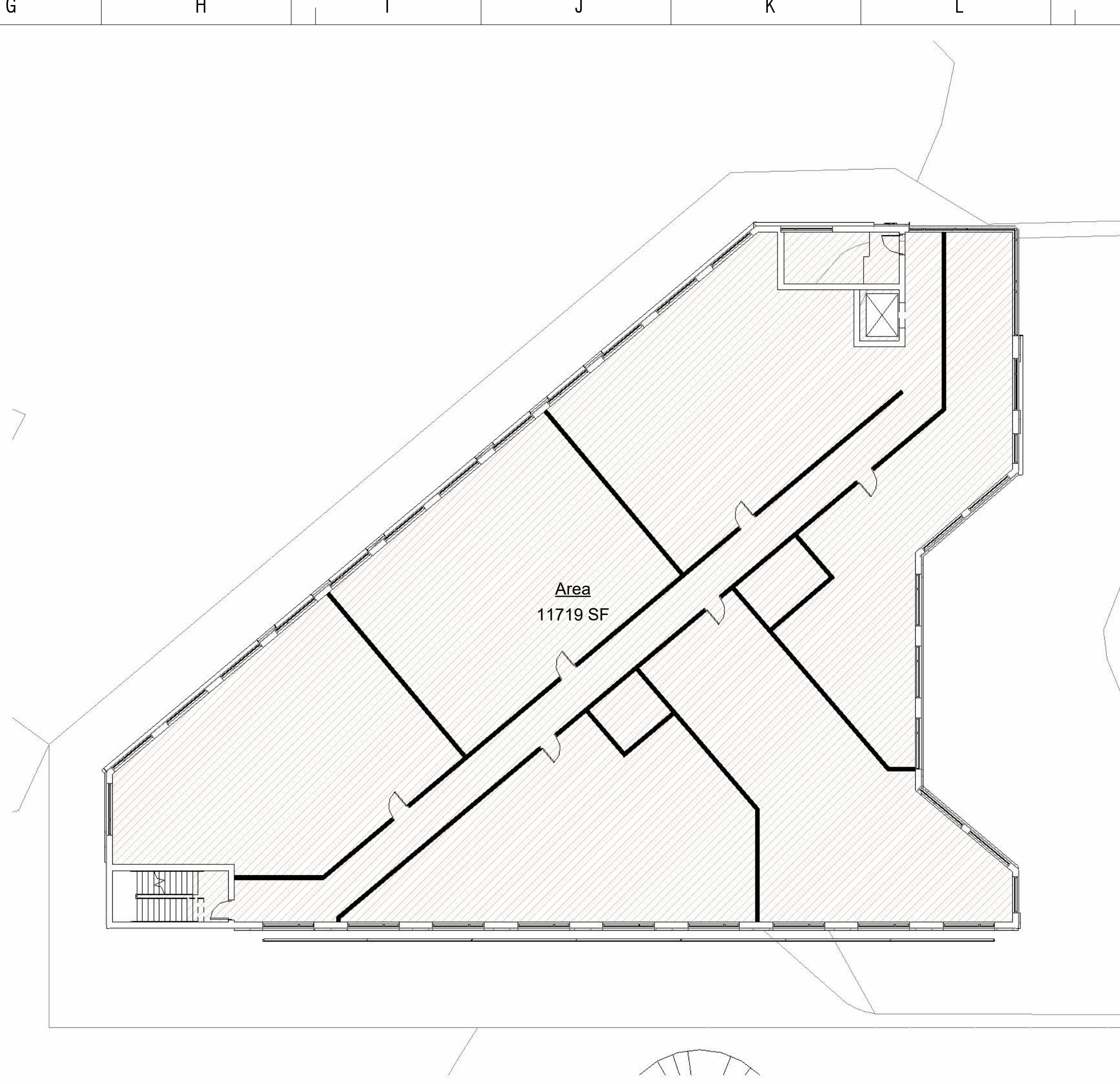

2 2ND FLOOR
1/16" = 1'-0"

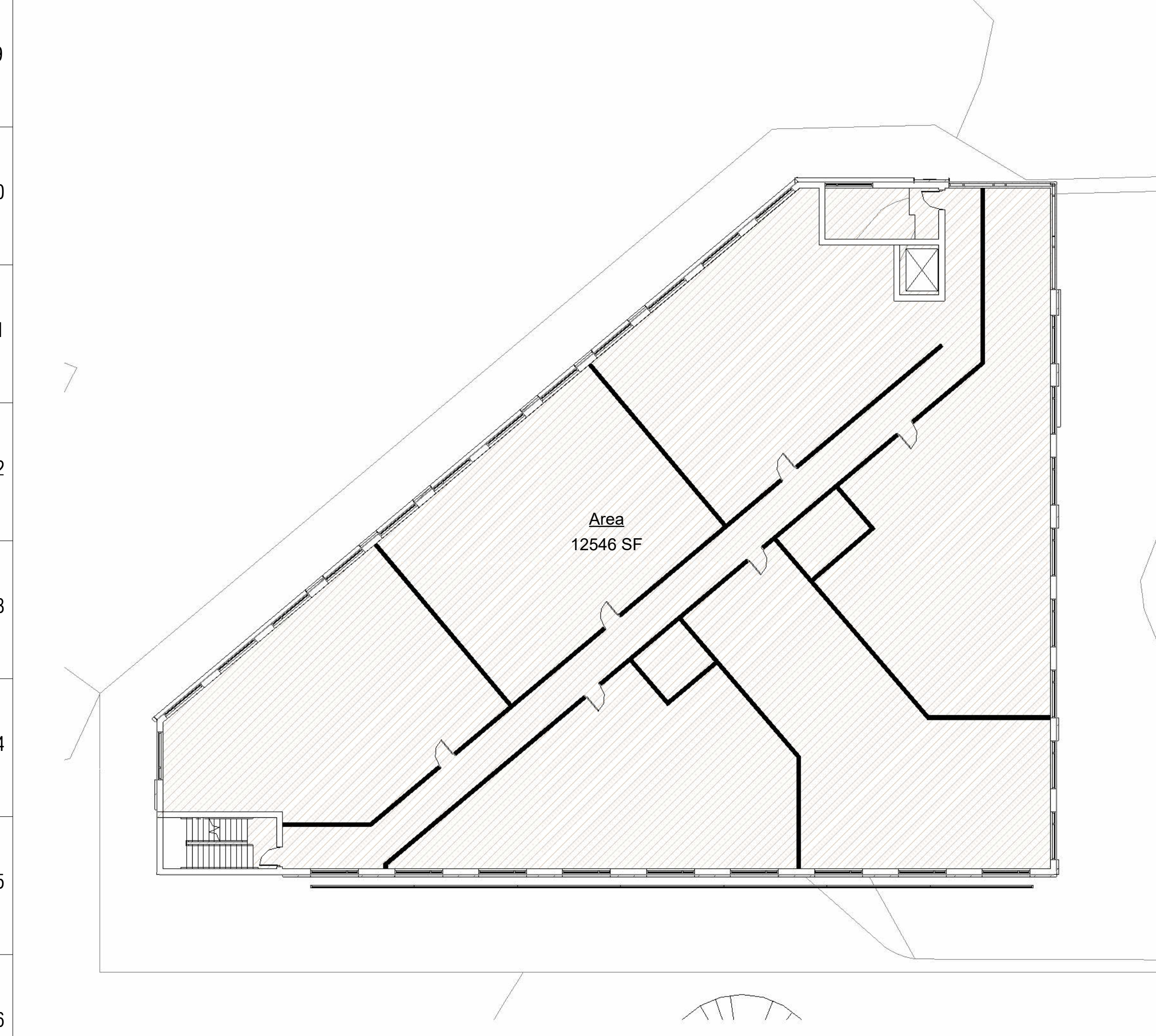

3 3RD FLOOR
1/16" = 1'-0"

DESIGN



BILD ARCHITECTURE

501 Chestnut Ridge RD
Suite 301
Chestnut Ridge, NY 10977
Tel 212.381.0670
info@bildny.com

CONSULTING ENGINEERS

CIVILTEC

139 Lafayette Avenue
2nd Floor
Suffern, NY 10901
P 845.547.2241

Description	Date

Revisions

Seal & Signature



CLIENT

MARK HERTZ

PROJECT NAME

OFFICE BUILDING

PROJECT LOCATION

365 Rt. 59, AIRMONT NY, 10952

JOB #:

Q08050448

FILING #

11

PROJECT NUMBER

22077

DRAWN BY

REVIEWED BY

Author

Checker

DATE:

06/29/22

DRAWING TITLE

AREA PLAN

A004

Scale
1/16" = 1'-0"

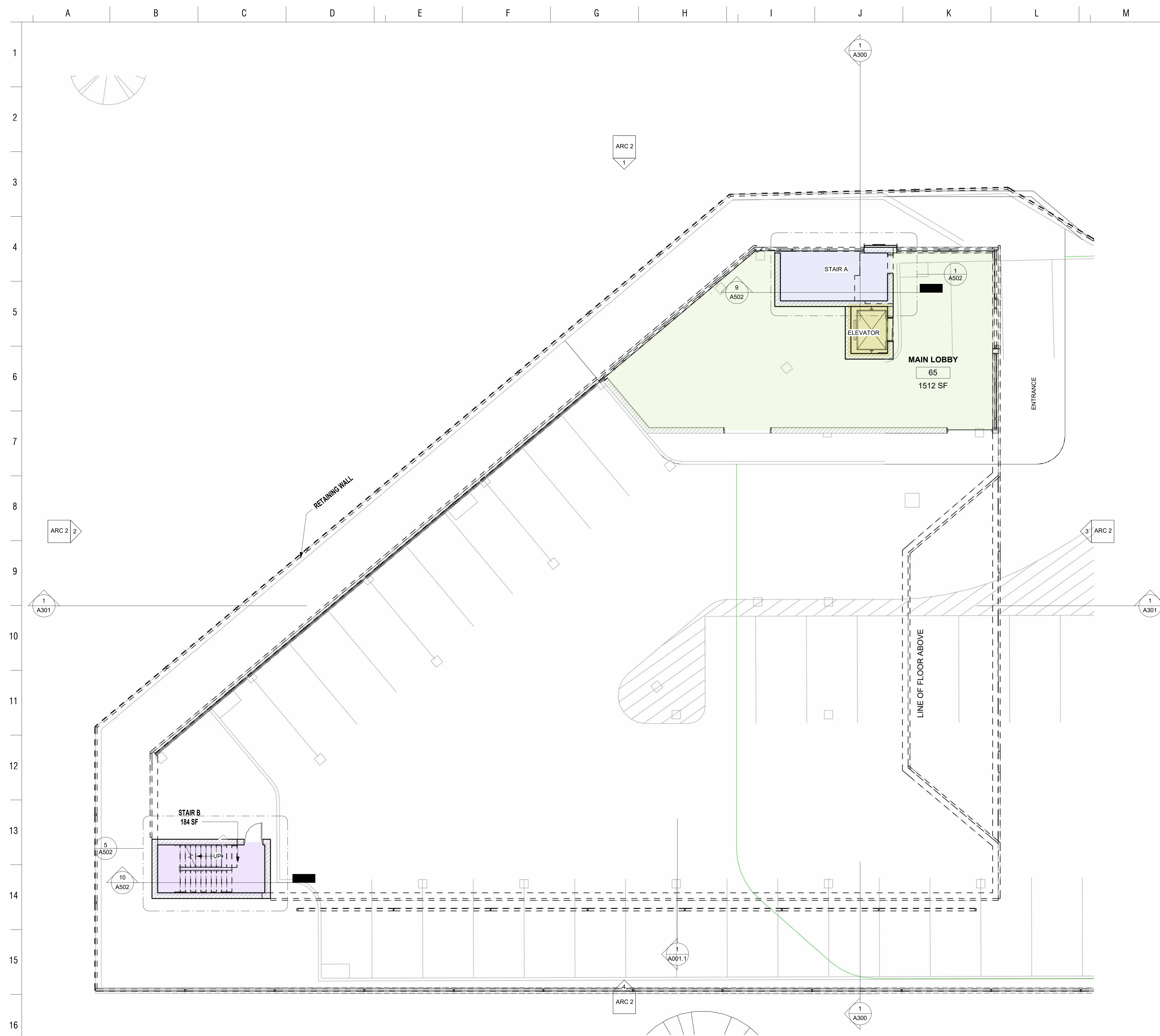

Keynote Legend	
Key Value	Keynote Text

DESIGN



BILD ARCHITECTURE

501 Chestnut Ridge RD
Suite 301
Chestnut Ridge, NY 10977
Tel 212.381.0670
info@bildny.com

CONSULTING ENGINEERS

CIVILTEC

139 Lafayette Avenue
2nd Floor
Suffern, NY 10901
P 845.547.2241

Description	Date
-------------	------

Revisions

Seal & Signature



CLIENT

MARK HERTZ

PROJECT NAME

OFFICE BUILDING

PROJECT LOCATION

365 Rt. 59, AIRMONT NY, 10952

JOB #:

Q08050448

FILING #

11

PROJECT NUMBER

22077

DRAWN BY

REVIEWED BY

Author

Checker

DATE:

06/29/22

DRAWING TITLE

1ST FLOOR

A101

Scale
1/8" = 1'-0"

1 1ST FLOOR
1/8" = 1'-0"

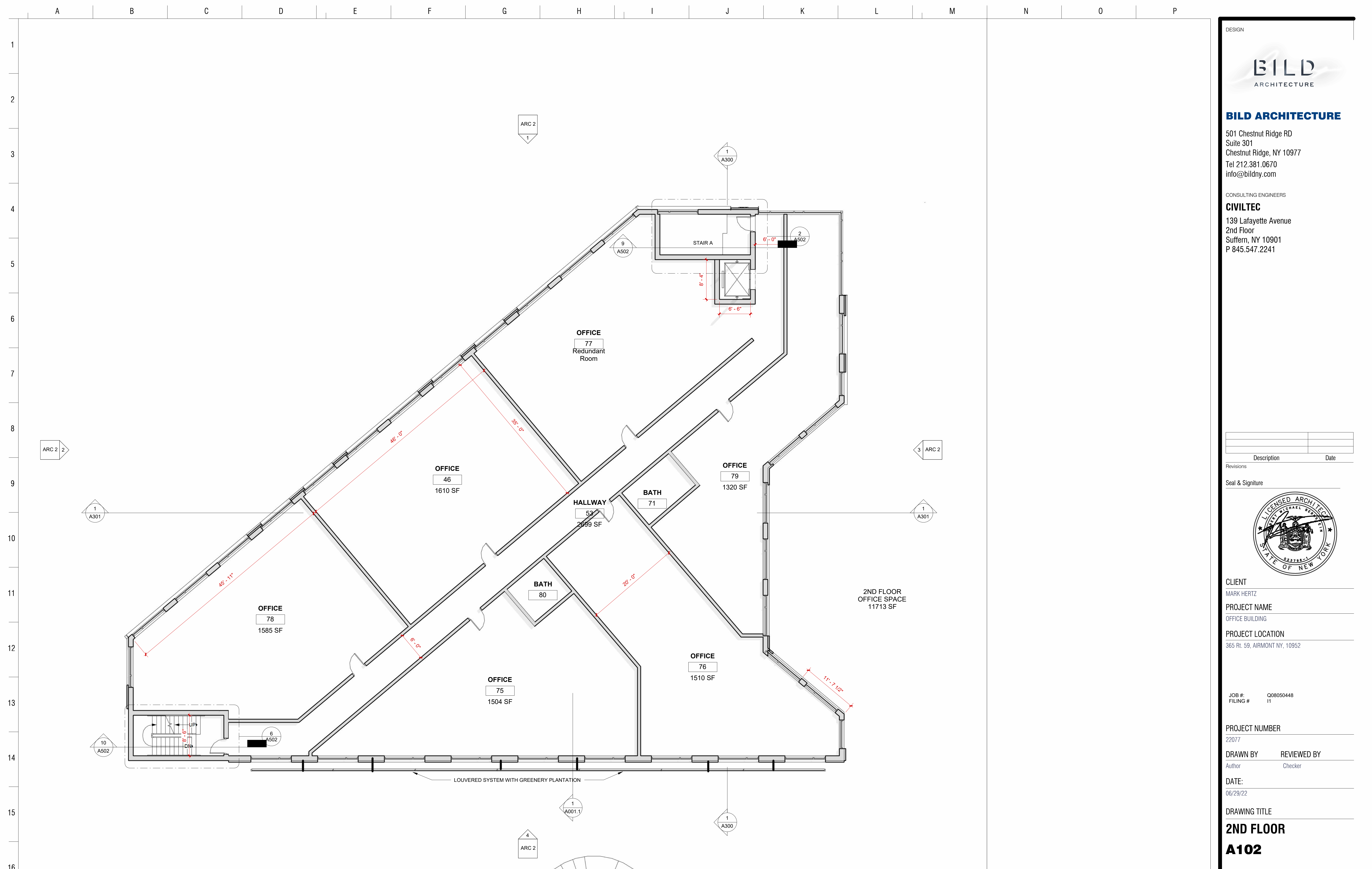

1 2ND FLOOR
1/8" = 1'-0"

DESIGN



BILD ARCHITECTURE

501 Chestnut Ridge RD
Suite 301
Chestnut Ridge, NY 10977
Tel 212.381.0670
info@bildny.com

CONSULTING ENGINEERS

CIVILTEC

139 Lafayette Avenue
2nd Floor
Suffern, NY 10901
P 845.547.2241

Revisions	Description	Date

Seal & Signature



CLIENT

MARK HERTZ

PROJECT NAME

OFFICE BUILDING

PROJECT LOCATION

365 Rt. 59, AIRMONT NY, 10952

JOB #:

Q08050448

FILING #

11

PROJECT NUMBER

22077

DRAWN BY

REVIEWED BY

Author

Checker

DATE:

06/29/22

DRAWING TITLE

2ND FLOOR

A102

Scale
1/8" = 1'-0"

A B C D E F G H I J K L M N O P

1
2
3
4
5
6
7
8

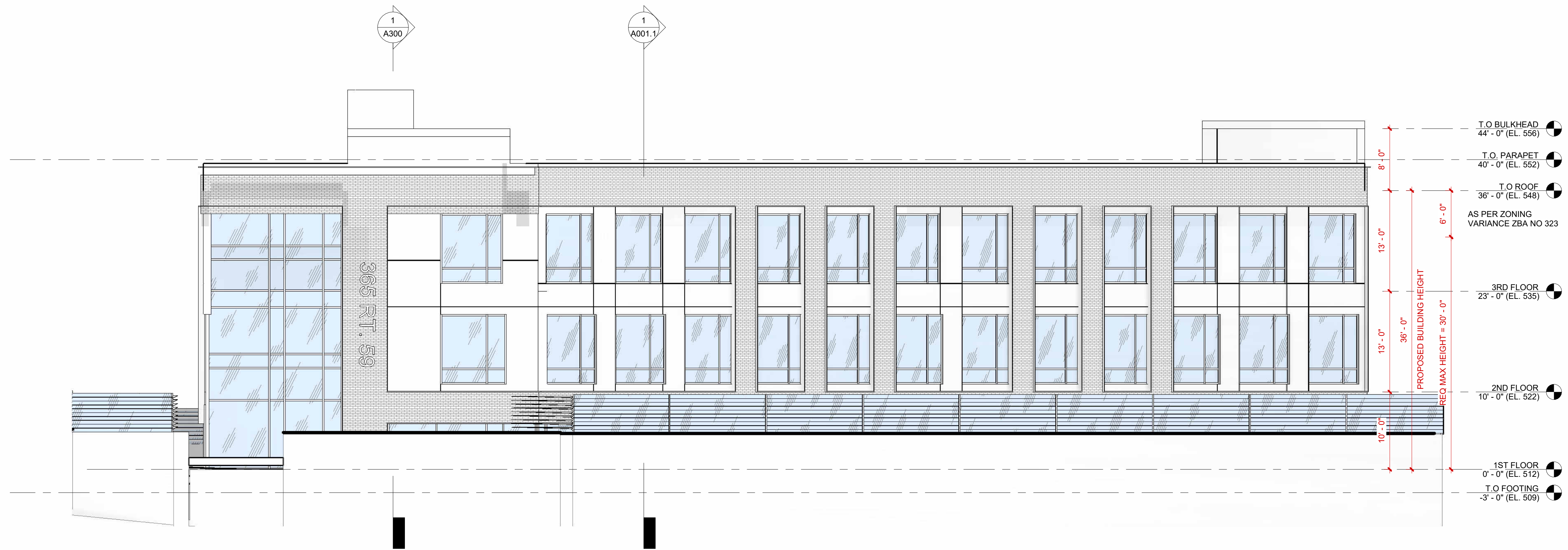

1 East
1/8" = 1'-0"

9
10
11
12
13
14
15
16

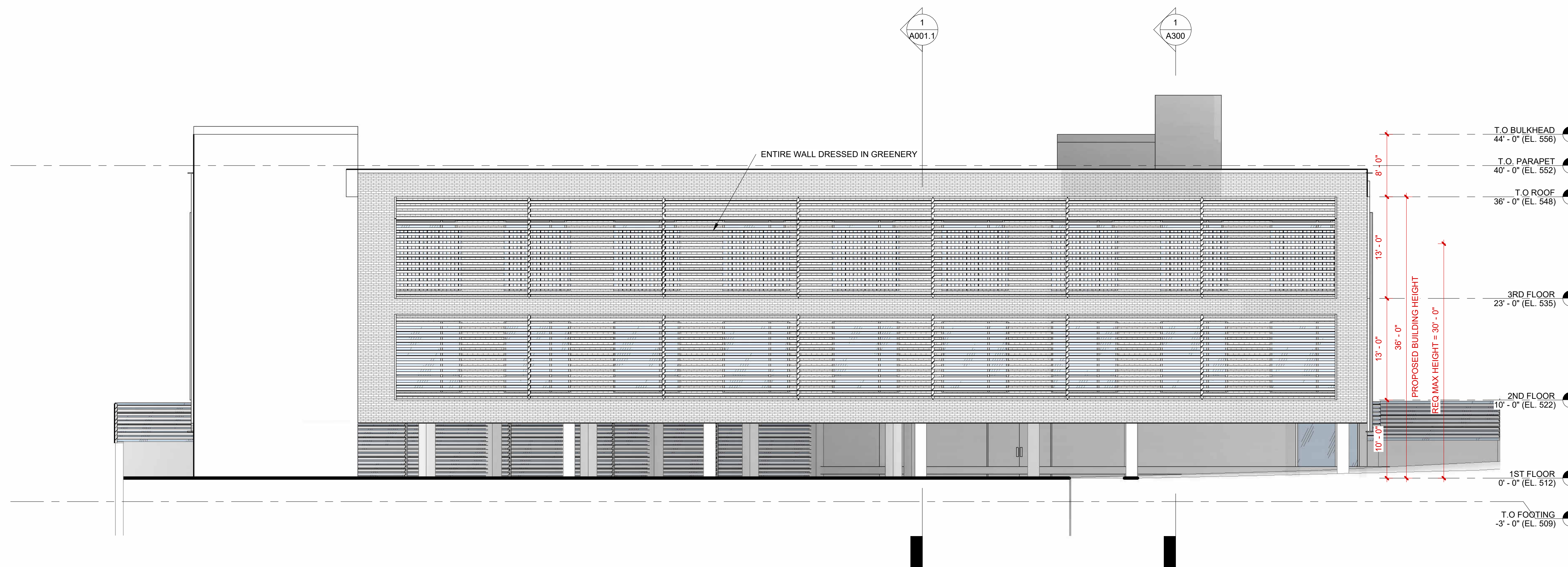

2 West
1/8" = 1'-0"

DESIGN



BILD ARCHITECTURE

501 Chestnut Ridge RD
Suite 301
Chestnut Ridge, NY 10977
Tel 212.381.0670
info@bildny.com

CONSULTING ENGINEERS

CIVILTEC
139 Lafayette Avenue
2nd Floor
Suffern, NY 10901
P 845.547.2241

Description	Date

Revisions

Seal & Signature



CLIENT

MARK HERTZ

PROJECT NAME

OFFICE BUILDING

PROJECT LOCATION

365 Rt. 59, AIRMONT NY, 10952

JOB #: Q08090448
FILING #: 11

PROJECT NUMBER

22077

DRAWN BY REVIEWED BY

Author Checker

DATE:

06/30/22

DRAWING TITLE

ELEVATIONS

A200

Scale
1/8" = 1'-0"

A B C D E F G H I J K L M N O P

1
2
3
4
5
6
7
8
9
10
11
12
13
14
15
16

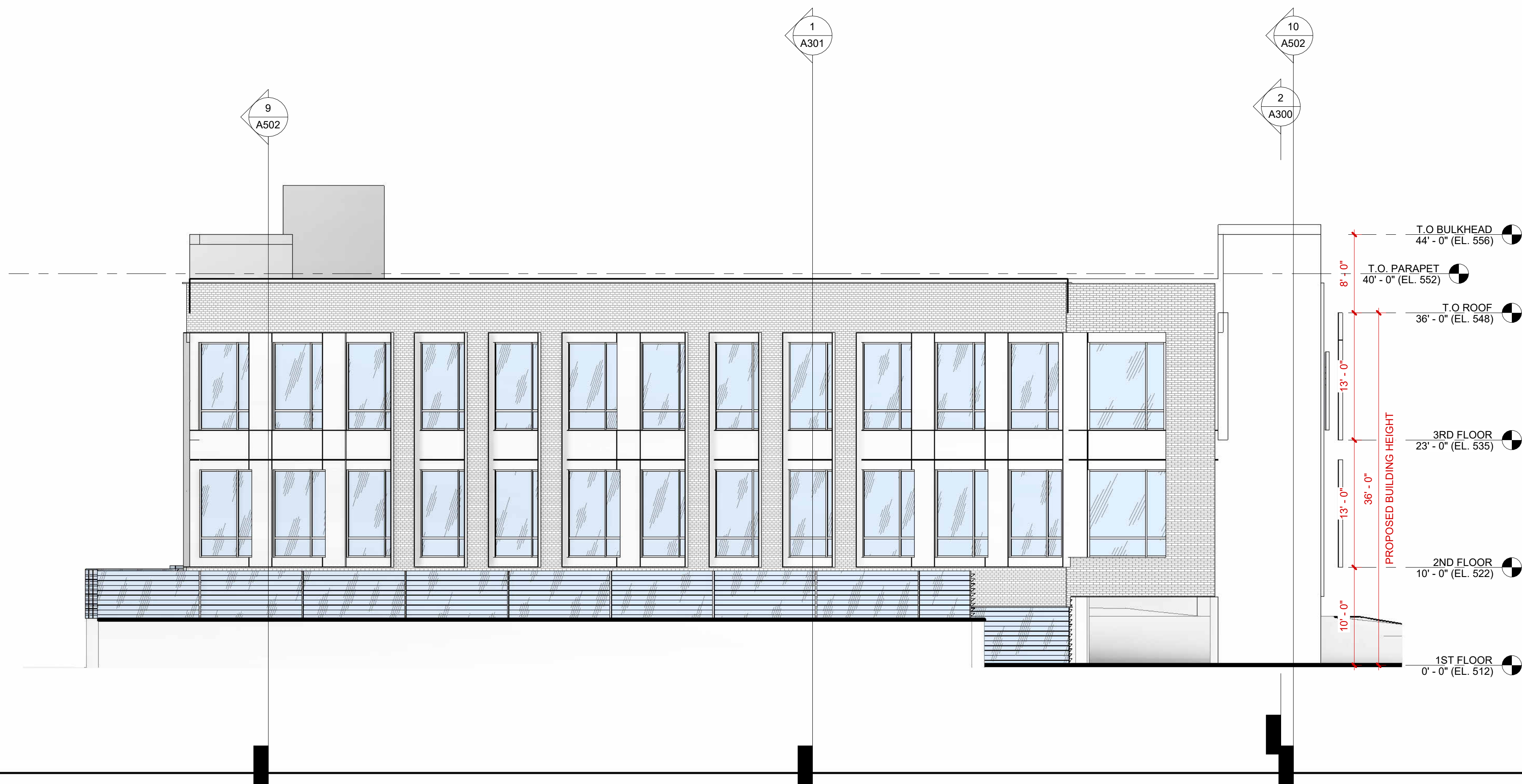

2 North
1/8" = 1'-0"



1 South
1/8" = 1'-0"

DESIGN



BILD ARCHITECTURE

501 Chestnut Ridge RD
Suite 301
Chestnut Ridge, NY 10977
Tel 212.381.0670
info@bildny.com

CONSULTING ENGINEERS

CIVILTEC

139 Lafayette Avenue
2nd Floor
Suffern, NY 10901
P 845.547.2241

Revisions	Description	Date

Seal & Signature



CLIENT

MARK HERTZ

PROJECT NAME

OFFICE BUILDING

PROJECT LOCATION

365 Rt. 59, AIRMONT NY, 10952

JOB #:

Q08050448

FILING #

11

PROJECT NUMBER

22077

DRAWN BY

Author

REVIEWED BY

Checker

DATE:

06/30/22

DRAWING TITLE

ELEVATIONS

A201

Scale
1/8" = 1'-0"

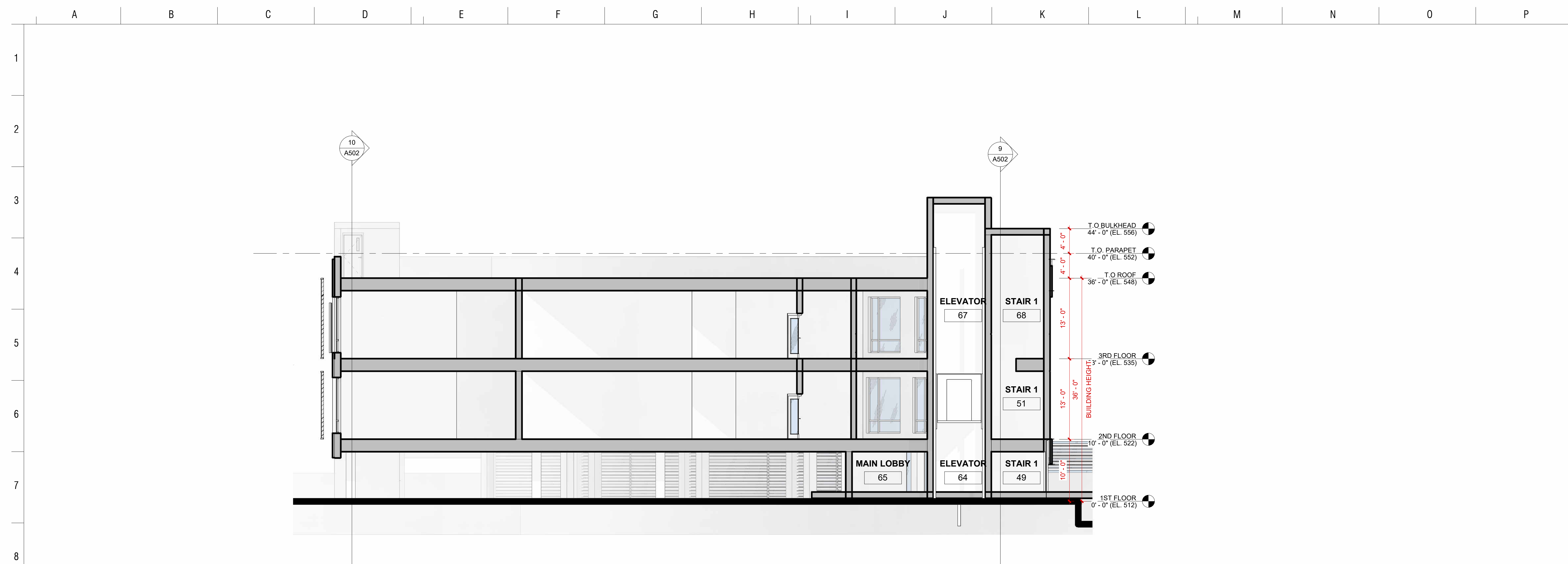

1 Section 1
1/8" = 1'-0"

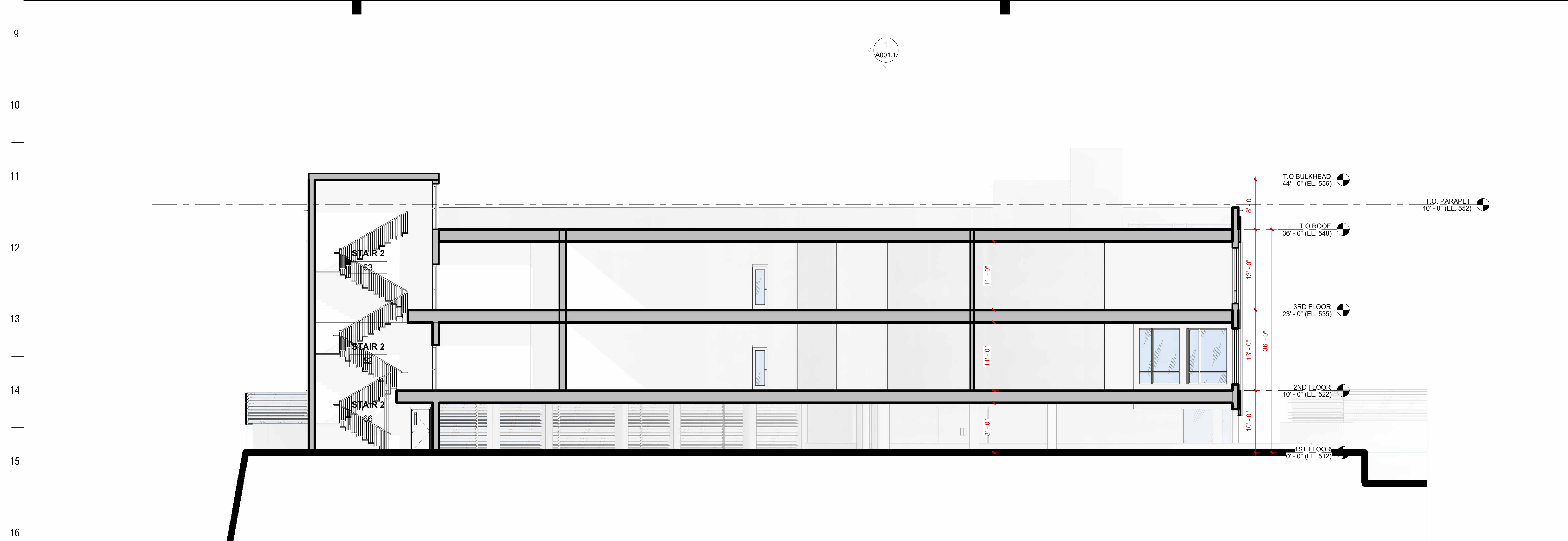

2 Section 2
1/8" = 1'-0"

DESIGN



BILD ARCHITECTURE

501 Chestnut Ridge RD
Suite 301
Chestnut Ridge, NY 10977
Tel 212.381.0670
info@bildny.com

CONSULTING ENGINEERS

CIVILTEC

139 Lafayette Avenue
2nd Floor
Suffern, NY 10901
P 845.547.2241

Revisions	Description	Date

Seal & Signature



CLIENT

MARK HERTZ

PROJECT NAME

OFFICE BUILDING

PROJECT LOCATION

365 Rt. 59, AIRMONT NY, 10952

JOB #:

Q08050448

FILING #

11

PROJECT NUMBER

22077

DRAWN BY

REVIEWED BY

Author

Checker

DATE:

06/30/22

DRAWING TITLE

SECTIONS

A300

Scale
1/8" = 1'-0"



1 Section 3
1/8" = 1'-0"

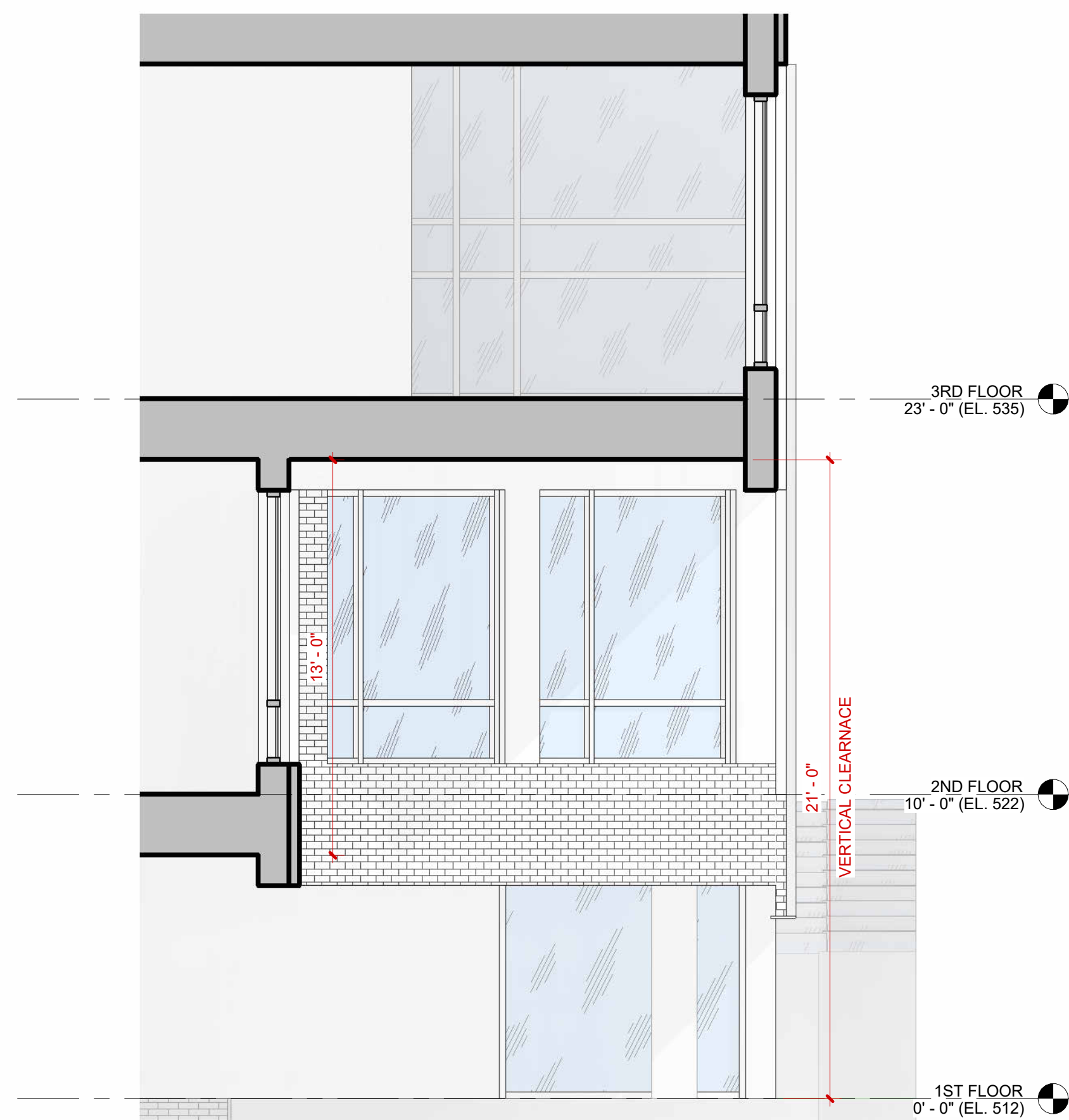

2 Section 3 - Callout 1
1/4" = 1'-0"

DESIGN



BILD ARCHITECTURE

501 Chestnut Ridge RD
Suite 301
Chestnut Ridge, NY 10977
Tel 212.381.0670
info@bildny.com

CONSULTING ENGINEERS

CIVILTEC

139 Lafayette Avenue
2nd Floor
Suffern, NY 10901
P 845.547.2241

Description	Date

Revisions

Seal & Signature



CLIENT

MARK HERTZ

PROJECT NAME

OFFICE BUILDING

PROJECT LOCATION

365 Rt. 59, AIRMONT NY, 10952

JOB #: Q08050448
FILING #: 11

PROJECT NUMBER

22077

DRAWN BY

Author

REVIEWED BY

Checker

DATE:

06/30/22

DRAWING TITLE

SECTIONS

A301

Scale
As indicated

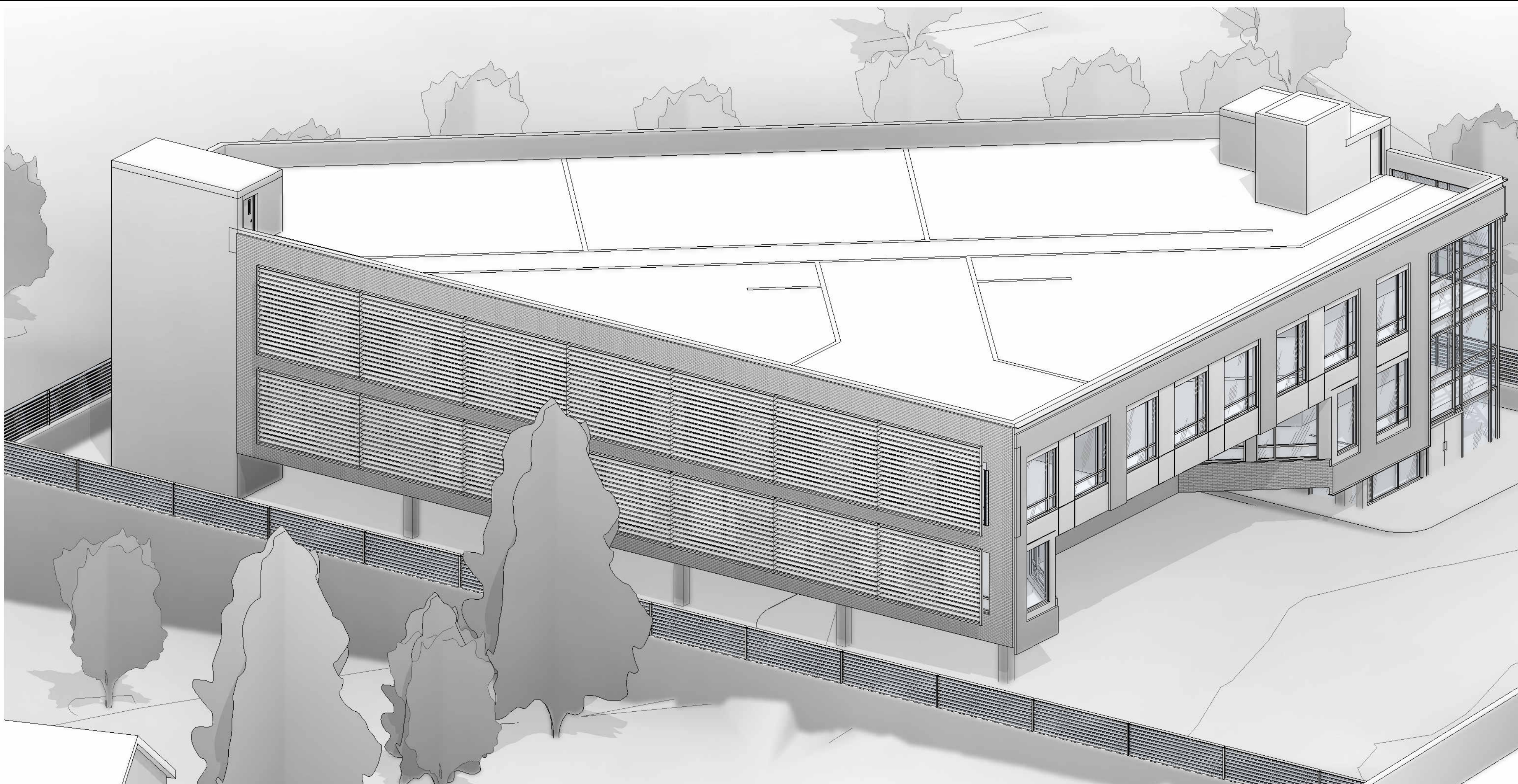

DESIGN



BILD ARCHITECTURE

501 Chestnut Ridge RD
 Suite 301
 Chestnut Ridge, NY 10977
 Tel 212.381.0670
 info@bildny.com

CONSULTING ENGINEERS

CIVILTEC

139 Lafayette Avenue
 2nd Floor
 Suffern, NY 10901
 P 845.547.2241

Description	Date

Revisions

Seal & Signature



CLIENT

MARK HERTZ

PROJECT NAME

OFFICE BUILDING

PROJECT LOCATION

365 Rt. 59, AIRMONT NY, 10952

JOB #: Q08050448

FILING #: 11

PROJECT NUMBER

22077

DRAWN BY

Author

REVIEWED BY

Checker

DATE:

06/30/22

DRAWING TITLE

3D AXON PLAN

A800

Scale