

SHOPPES ON EAST STONE DRIVE

2637 East Stone Drive
Kingsport, TN 37660

Location

Directly across from Kingsport Pavilion on East Stone Drive in East Kingsport

Available for Lease

Suite E: 1,200 SF
\$16/SF/year NNN

Highlights

Highly visible center across from Target & Kohls

Signage opportunities on building, plus a panel on the pylon sign at East Stone Drive

Floor-to-ceiling windows provide natural light

Wet sprinkler system

Easily accessible from a traffic light

Traffic Counts

E Stone Dr: 25,829 (2022)

Demographics

(2024 Est.)	3 mile	5 mile	10 mile
Population	32,570	59,759	127,888
Median HH Income	\$53,074	\$52,118	\$58,477
Median Age	46.2	45.2	45.8

Contact

John Speropoulos, CCIM, SIOR
john@mitchcox.com

Marc Murphy, CCIM
mmurphy@mitchcox.com

📞 423-282-6582 | 📠 423-282-5903
www.mitchcox.com



Subject ★

Academy
KOHL'S
Bath & Body Works
BAM!
Michaels
CVS
Great Clips
maurices
U.S. Walk
Target
bealls
ULTA
DOLLAR TREE
RACK ROOM SHOES
Pizzeria
U.S. Walk
Essentials

ASHLEY
Furniture
Firestone
COMPLETE AUTO CARE
magoo's
OUTLET

PANERA
BREAD EXPRESS
Spadley's
STEAKBURGERS
ZAXBY'S

ALDI

verizon
Mobile

DISCOUNT
TIRE

LOWES

WALMART

SLEEPZONE
MATTRESS CENTRAL

Citizens
BANK

SOUTHEASTERN
RETINA ASSOCIATES

3 Express
Car Wash

VW

HONDA

LEXUS

TOYOTA

Don Hill

Grocery
THE GROCERY STORE

NHC
NORTH HAVEN COMMUNITY CENTER

INDIAN PATH
MEDICAL CENTER

Red Roof
Inn

NEW
PEOPLES BANK

Balad
Health

at&t

U-HAUL
AUTHORIZED DEALER

Hampton
HOTEL

Winder
Center
Nursing Center

N John B Dennis Hwy

Estor Rd

N John B Dennis Hwy

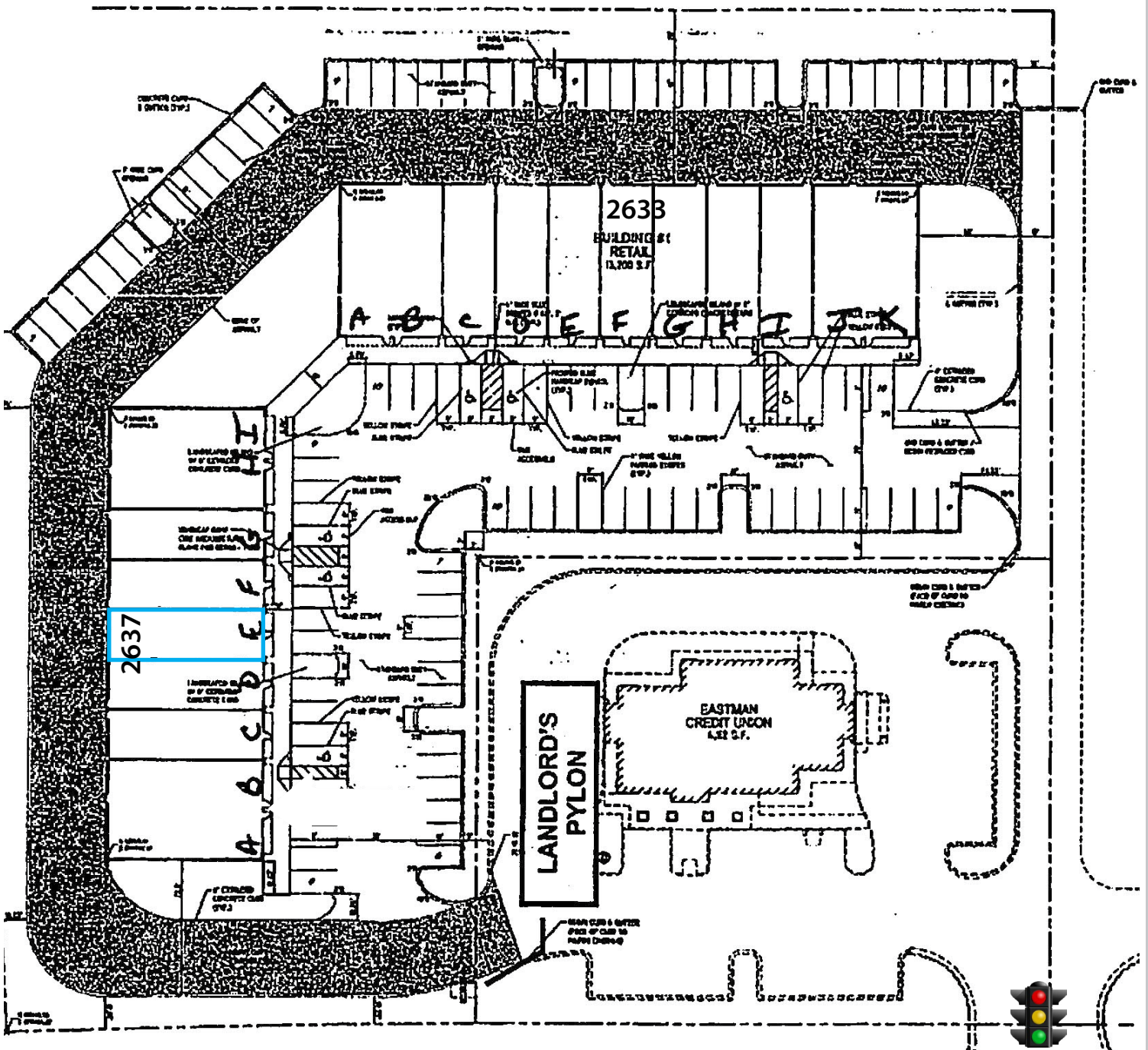

EAST STONE DRIVE (U.S. HIGHWAY 11-W)



CALL BEFORE YOU DIG
 BEFORE YOU DIG
 1-800-351-1111
 TOLLFREE ONE CALL SYSTEM, INC.



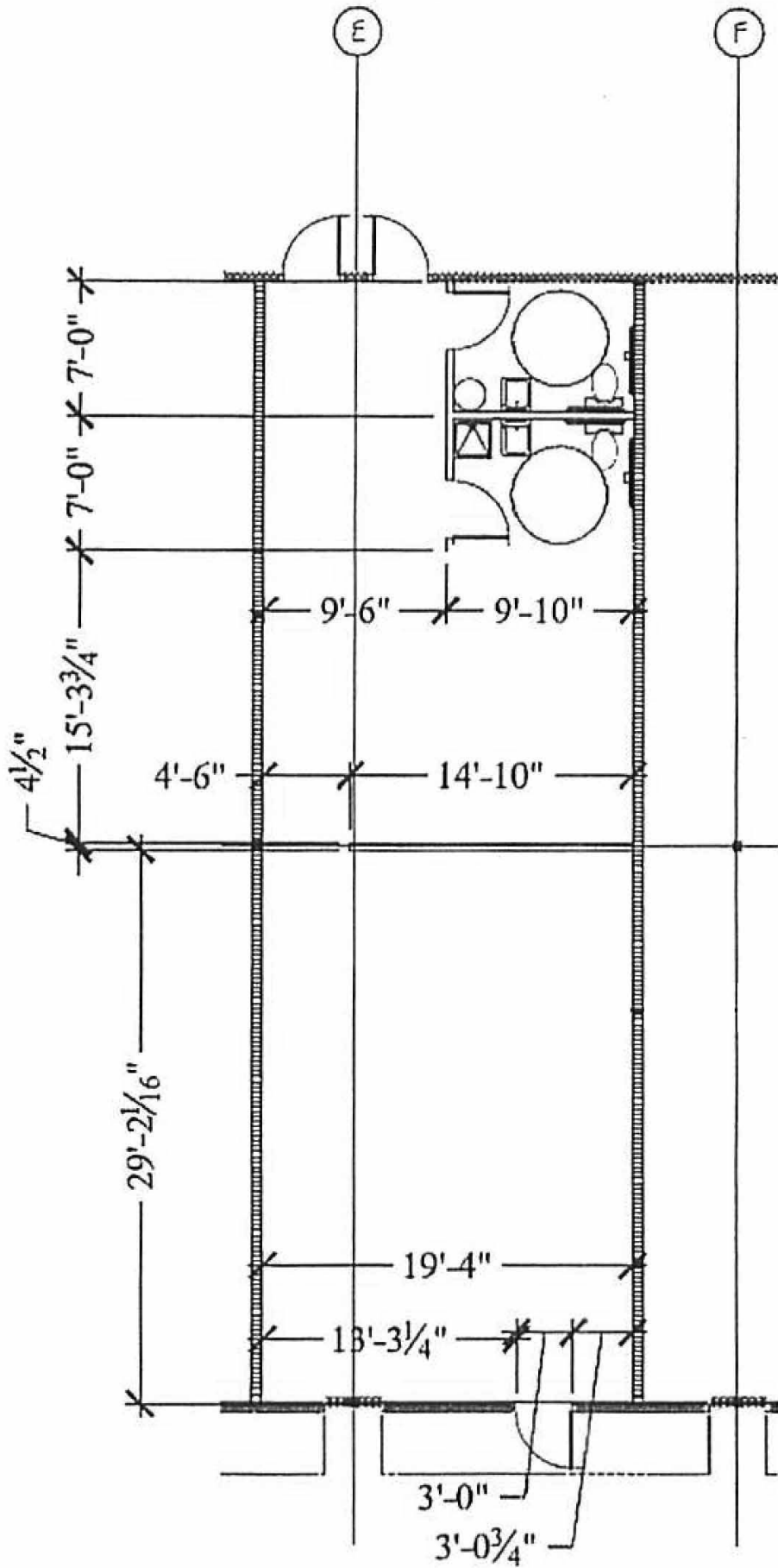

MITCH COX
REALTOR, INC.

2304 Silverdale Drive, Suite 200, Johnson City, TN 37601
423-282-6582 (o) 423-282-5903 (f) www.mitchcox.com